



# Table of Contents

- What’s New..... 3
- 1.0 Introduction ..... 4
- 2.0 SURVEY GUIDELINES..... 5
  - 2.1 Detailed Survey Requirements..... 5
  - 2.2 Drainage Area Information Survey Requirements ..... 12
- 3.0 DRAWING REQUIREMENTS ..... 13
  - 3.1 General Requirements ..... 13
  - 3.2 Symbology & Labeling ..... 16
  - 3.3 Dimensions & Elevations..... 18
  - 3.4 Landscape Plans ..... 18
- 4.0 CAD STANDARDS ..... 20
  - 4.1 CAD Platforms to Utilize..... 20
  - 4.2 Templates..... 20
  - 4.3 Graphic Concepts and Standards ..... 21
  - 4.4 Deliverables and Data Exchange ..... 23
  - 4.5 File Naming Convention and Standard Reference Files ..... 24
  - 4.6 Layer Naming Convention ..... 24
  
- Appendix A. Callout and Block Library
- Appendix B. Linetypes and Hatching
- Appendix C. Lettering Standards and Text, Multileader, Dimension and Table Styles
- Appendix D. Dynamic Block Functions
- Appendix E. Recommended Drafting Tips
- Appendix F. Example Plans

# What's New

**Effective Date:** January 2021 – Additional updates from May 2021 noted with an asterisk (\*)

Revisions History: Listed below are the major changes that occurred between the 2018 version of the GSI Survey & Drawing Standards and this most recent 2021 version.

## 1.0 INTRODUCTION

- Clarified that water/sewer sheets added to a GSI planset should still follow Water/Sewer standards.

## 2.0 SURVEY GUIDELINES

- Added ponding in ROW to list of items to look out for when making field observations.
- Clarified that pavement markings should reflect the width/thickness measured in the field.
- Clarified that roadway paving material should only be called out if it differs from asphalt.
- Added trash cans, planter boxes, and bike racks to example list of street furniture to be identified.
- Added requirement to show downspouts if proposed system is located in adjacent ROW.
- Clarified that abandoned utilities and stubbed laterals should be shown if in the detailed survey area rather than “in the vicinity of proposed system”.
- Cross-sections are only needed at proposed green inlet locations based on proposed system layouts in planning package, rather than upstream of all existing inlets.

## 3.0 DRAWING REQUIREMENTS

- “Centralized GSI Facility” replaced “Large Area Disconnection” terminology.
- Clarified that components in elevation views should be drafted relative to the street center line.
- Added requirement to show 2V:1H sewer zone of influence line as well as the projection lines that define limits of impermeable geomembrane liner in cross sections and profile/elevation views. These lines should be removed at PS&E and Final Design phase.
- Added guidance to not show overhead wires on G sheets (only baseplan and landscape sheets).
- Added guidance that abandoned utilities and stubbed laterals may be removed from design plans if they make the plan too crowded and are located outside of proposed area of excavation.
- In order to avoid having to make later edits, Maintenance Component ID numbers are now assigned by GSO during PS&E design review after PWD project manager confirms components are finalized.
- Removed common required elevation callouts and instead referred to Appendix A.
- Added guidance to include dimensions of horizontal offsets from existing street features that impact the location for proposed work.
- Added guidance that tree blocks should not be used for tree trenches on landscape plans.
- “Tree Location ID” replaced “Tree Pit ID” terminology. Updated Tree Location ID labeling guidance\*
- Updated guidance on how varying soil depth should be depicted on G-series sheets.\*

## 4.0 CAD STANDARDS

- Updated file sharing guidance.
- Converted color-based plot style to a style-based plot style.
- Updated baseplan and design callout libraries.
- Revised existing linetypes and hatches.
- Updated block library with revisions to existing blocks and additional blocks.
- Updated example plans to reflect current drawing standards. Updates included replacing some plans to present more typical scenarios.

# 1.0 INTRODUCTION

This resource provides standardized survey, drawing, and Computer Aided Design (CAD) requirements that must be used when drafting contract plans for all Green Stormwater Infrastructure (GSI) projects funded and/or maintained by the Philadelphia Water Department (PWD). The following information is to be used throughout the design process by PWD staff, providers of professional engineering services contracted by PWD, and other agencies/partner organizations that are working with the Department. All PWD GSI drawings must, at a minimum, meet the standards outlined within this document.

## Part One

Details the requirements for GSI surveys and baseplans. Survey work is divided into two general categories:

- **Detailed Survey** – Provides requirements for surveying on-street and off-street locations where GSI will be installed. Survey includes collecting detailed information about surface elevations, underground utilities, and surface features.
- **Drainage Area Information Survey** – Provides requirements for gathering information about the drainage areas contributing to GSI systems. Survey includes combining City Plan Information with minimal surface elevation information to delineate the terminating points of the contributing drainage area.

## Part Two

Includes an overview of general drawing requirements that should apply to all projects including specific guidance on system/SMP numbering, maintenance component IDs, and drafting landscape plans.

## Part Three

Provides all necessary information for using the GSI CAD Standards. The GSI CAD Standards include drafting standards, templates, standard callouts, and block libraries to standardize GSI drawings provided by GSI Unit Design Consultants.

## Appendices

Provides all standard callouts, line types, lettering standards, and block libraries as well as example plans to illustrate the requirements of sheet layout, design plans, and landscape plans.



### Note on Water & Sewer Standards:

This resource builds on standards defined in the PWD Department **Water & Sewer Design Manual**. Design professionals working on PWD GSI may find it useful to familiarize themselves with the *Water & Sewer Design Manual* sections on **Contract Drawings** and **Drawing Standards**. Water/sewer sheets added to a GSI work number should follow Water & Sewer standards.

<http://www.phillywaterdesign.org>

## 2.0 SURVEY GUIDELINES

### 2.1 Detailed Survey Requirements

#### 2.1.1 On-Street Extents & Elevations

1. Provide spot elevations for the houseline or protruding feature (steps, window wells, etc), top of curb, bottom of curb, and centerline for both sides of the street taken at 25-foot horizontal intervals.
2. Provide sufficient spot elevations at corners where ADA ramp replacement may be required.
3. Provide sufficient spot elevations for sidewalk grading plans for bumpout systems. See *Streets Design Guidance for GSI Projects*.
4. Where there is an obvious localized sump, provide, at a minimum, labeled spot elevations for the centerline, building line, top of curb, and bottom of curb for both sides of the street to adequately define the sumped area.
5. Provide labeled elevations for the point of curvature (PC), point of intersection (PI), and point of tangency (PT) at both the bottom and top of curb at intersections.
6. Extend the survey a minimum of 50 feet (horizontal) up both sides of any intersecting streets or alleys in either direction.
7. Show one (1) foot contours on baseplans. Contours may ultimately be removed from final design plans to improve plan clarity.
8. Survey locations for existing features as described in the following sections.

#### 2.1.2 Off-Street Extents & Elevations

1. Provide spot elevations on a 25-foot grid, or as necessary to provide ½ foot contours, extending 50 feet horizontal outside the Detailed Survey area identified by PWD.
2. Ensure that the survey is tied into an adjacent intersection between two cartways or a cartway and a facility entrance.
3. Show ½ foot contours on baseplans. Contours may ultimately be removed from final design plans to improve plan clarity.
4. Provide surveyed locations for existing features as described in the following sections.

#### 2.1.3 City Plan Information

1. Show curb and right-of-way (ROW) lines from City Plan. Where the curb differs from City Plan or does not exist, show the City Plan curb line as a dashed line.
2. Label the extents of ROW distance and angles.
3. Label block lengths/distances. Label should be placed adjacent to the ROW line.
4. Label all street grades, with label shown along the gutter.
5. Include cartway and footway width dimensions in both plan and section views.
6. Label street, including State Route numbers (SR#'s). If the street is not legally open, label as such in the street callout.
7. Label City Plan elevations at all corners and mid-block change in grades.
8. Place arrow heads on the curb pointing in the direction of stormwater surface flow.

## 2.1.4 Plan View Information

Field Observations – The final design is dependent on the information obtained during field investigations. Designers who visit the field locations should pay special attention to the visible details of the site which may be useful in making design decisions later. Examples of such items are:

- ✓ Condition of paving, signs of paving disruptions, deterioration, etc. This information will assist in establishing appropriate paving limits.
- ✓ Ponding in ROW.
- ✓ Potential construction interferences such as low bridges, tree interference, overhead wires or structures, downspouts disconnected to the ROW, etc.
- ✓ Condition of buildings (vacant, collapsing, etc.)
- ✓ Neighborhood gardens and landscaped areas

1. Benchmarks
  - a. List the benchmark obtained from the Streets Department Survey District in the upper right-hand corner.
  - b. If the obtained benchmark is more than one turning point away from the proposed work, then a local benchmark should be set. The local benchmark should be outside of the proposed limit of disturbance and on a permanent structure. The local benchmark should be listed in addition to the benchmark obtained from the Streets Department Survey District.
  - c. Drill holes should be avoided when setting a benchmark and manhole rims should not be cited as benchmarks unless identified by chisel cut markings and outside of vehicular travel lanes.
2. Right-of-Way Information
  - a. Place the name of the main street along the top of the sheet without using abbreviations.
  - b. Draft pavement markings to reflect the width/thickness measured in the field.
  - c. Abbreviate the words – street, road, avenue, etc. – on intersecting streets.
  - d. In the street label, show the direction of traffic along with parking and bike lane information on all streets including intersecting streets.
  - e. Use District Standard Measurement for all distances.
  - f. Show all overhead bridges and the elevation of the underside of bridges.
3. Paving Information
  - a. Identify the materials for the roadway, footway, and curb. Roadway paving material should only be called out if it differs from asphalt.
  - b. Show depressed curbs and driveways.
  - c. Indicate deteriorated footways and curbing.
  - d. Ensure that any special patterns for the footway are identified.
  - e. Label any obvious areas with drainage problems due to paving.
4. Existing Features
  - a. Identify all fences and walls and note the height and material.
  - b. Identify all steps, cellar doors, fire hydrants, parking meters, manhole covers, traffic signs and signals, stop signs, 20 ft. sign poles, utility poles, and all street furniture (phone booths, mailboxes, benches, trash cans, planter boxes, bike racks, etc.).
  - c. Identify any landscaped areas, and, if available, the owner (i.e. community garden sign).
  - d. Show all existing curb stops, sewer vent boxes, and gas valves.

- 5. Property Information
  - a. Indicate all properties and adjacent properties with street addresses and property lines.
  - b. Provide a general outline for all structures.
  - c. Provide general building information including use and construction (i.e. 3-story, brick, school).
  - d. Indicate where the interior of the property differs in elevation from the adjacent ROW by listing the change in elevation as a positive or negative.
  - e. Provide a general use and ground cover for properties without buildings (i.e. grass, park, garden, etc.).
  - f. Identify where property is vacant.
  - g. Show all gates, driveways, access points, etc. for properties.
  - h. Show downspouts if proposed system is located in adjacent ROW.
- 6. Trees
  - a. Label diameter at breast height (DBH) of all existing trees inside of the survey area.
  - b. Scale tree symbol to show the actual size of the tree canopy, but do not move point for trunk of tree when doing this. Canopies can be determined using aerials.
  - c. Show canopies that reach over into the survey area.
  - d. Trees adjacent to work within the LOD should either be listed as To Be Removed, or To Be Preserved. Trees being preserved should follow construction tree protection guidance listed in Chapter 5: Landscape Design Requirements of the [GSI Landscape Design Guidebook](#).

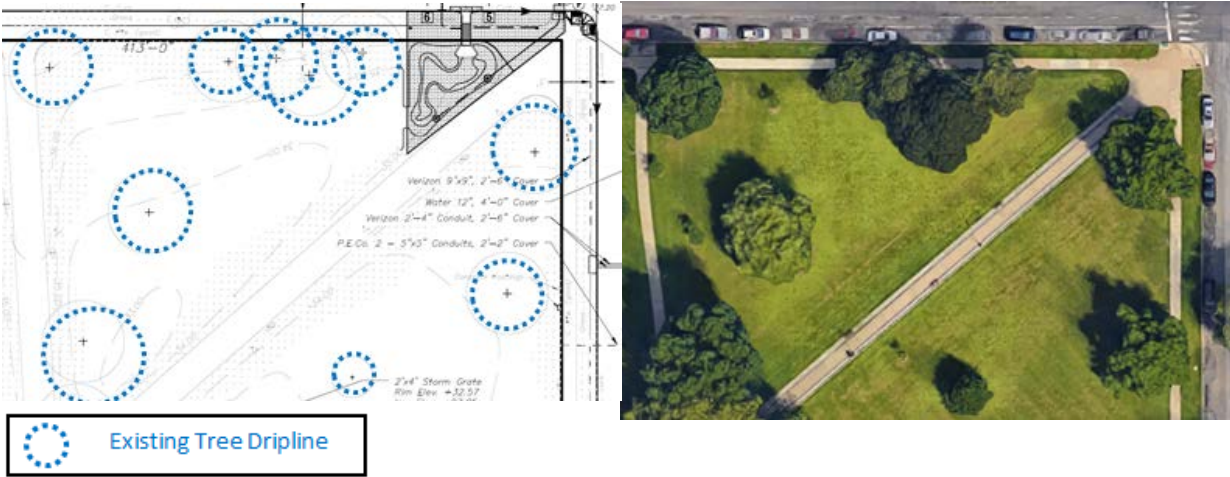

Figure 1 – Example of Tree Canopy on Plans

## 2.1.5 Utility Information

### **Note on Utility Location:**

If record drawings are not available from the property owner, then field testing, Ground Penetrating Radar (GPR), Closed-Circuit Television (CCTV), or Cable Avoidance Tool and Signal Generator (CAT and Genny) may be utilized to locate and inspect on-site underground private utilities.

1. Identify all existing utilities with owner, size, and cover.
2. List size by diameter or width x height.
3. Dimension all utilities from the curb line to the center line of the utility. Offset from the curb is to vary consistently between dimensions.
4. Show utilities as a double line when their width is 42 inches or greater, other than existing water and sewer as noted below.
  - a. All water mains 24 inches or greater in diameter...Double line.
  - b. Sewers with a width of over 21 inches...Double line with a center dimension line.
  - c. Brick sewers... Double line with a center dimension line.
  - d. Stormwater sewers ... Double line with a center dimension line.
5. Show all abandoned utilities in the detailed survey area.
6. Show SEPTA and railroad tracks as accurately as possible, but not dimensioned. List their status (active, inactive, or paved over).

### **Note on Paved Over SEPTA Trolley Tracks:**

SEPTA does not provide information through PA One Call for trolley tracks that have been paved over. Designers will need to use the Highway Supervisor Plans to get this information.

7. Sewer – list pipe size as height x width and as follows:
  - a. Brick sewers...Feet and inches (e.g. 2'-6" x 1'-8").
  - b. Reinforced concrete pipe...Inches (e.g. 36" RCP).
  - c. Box sewers (any material)...Feet and inches.
  - d. Callout all existing sewer manholes including the first manhole on each connecting sewer with a field invert, rim elevation, and owner if not PWD.
  - e. Show existing laterals over six (6) inches in diameter with the lateral size and material, where information is available.
  - f. Show abandoned or unused laterals “stubbed laterals” in the detailed survey area. Stubbed laterals can be identified on the sewer return plans by lines drawn perpendicular to the sewer which stop at the curb line and which cannot be verified as active laterals (no apparent vent box).



- 8. Inlets – Collect inlet information as follows:
  - a. Type
  - b. Top elevation (grate elevation for HWG and OMG inlets, top and bottom of curb elevations for City inlets)
  - c. Invert elevation of lateral to sewer
  - d. If inlet is owned by an entity other than PWD, callout the owner.
  - e. Note if inlet has a brick catch-basin.

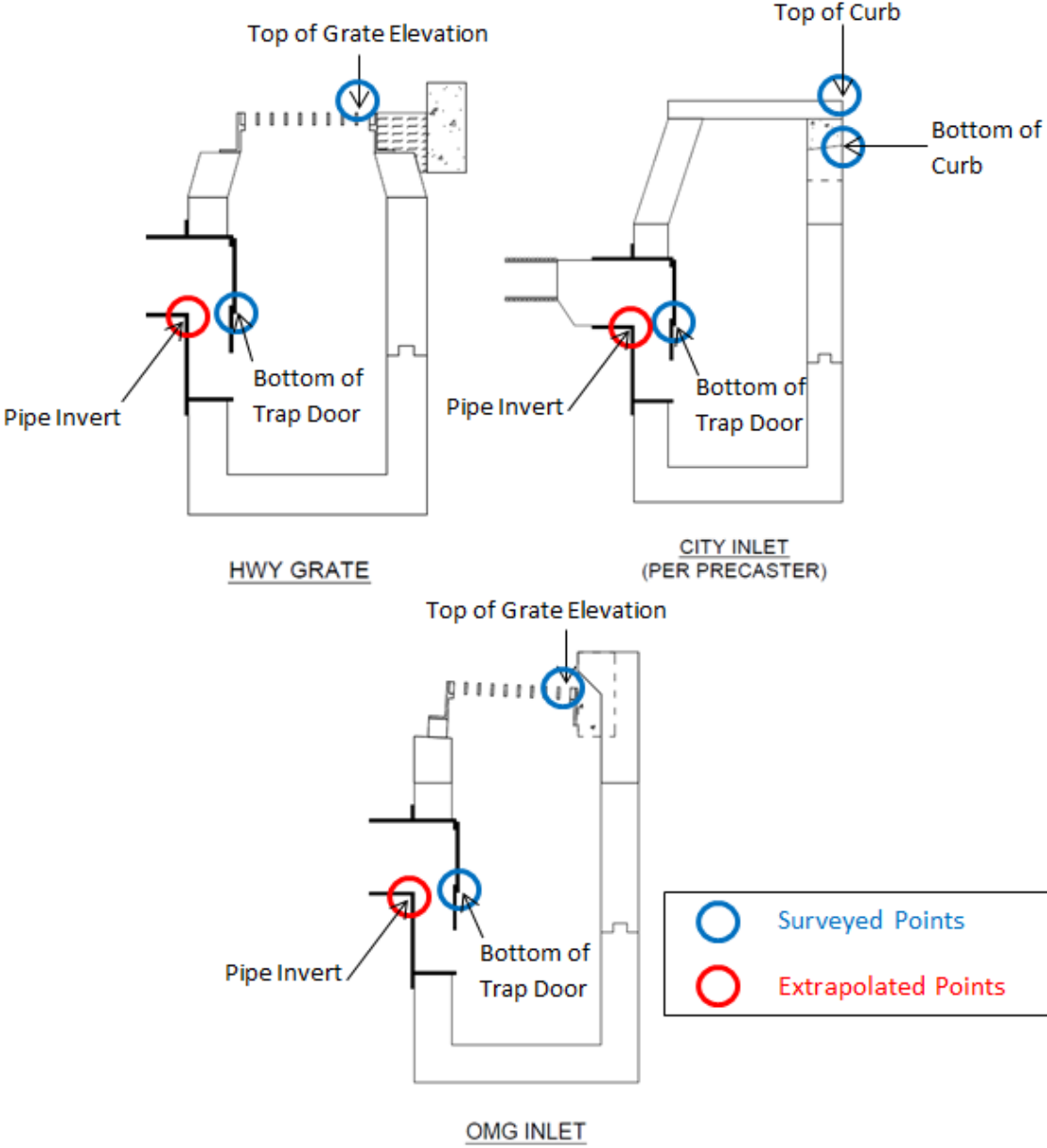

Figure 2 – Survey information for Inlets

## Inlet Survey Tips:

If inlets are completely clogged, work with the PWD project manager to submit an inlet cleaning request. PWD work number and PWD project manager should be included on all requests. Inlets with some trash/debris should still be able to be surveyed using these tips.

### Trap Door Measurement

If the inlet is constructed with a metal trap and trap door, the depth of the inlet lateral invert can be obtained by measuring from the top of the dripstone (BC) to the bottom of the trap door. As shown in *Figure 3* below, the bottom of the trap door is the same elevation as the lateral invert. Unless an inlet is experiencing operational issues preventing the lateral pipe from conveying stormwater, the water level in this type of inlet should always be at or below the bottom of the trap door.

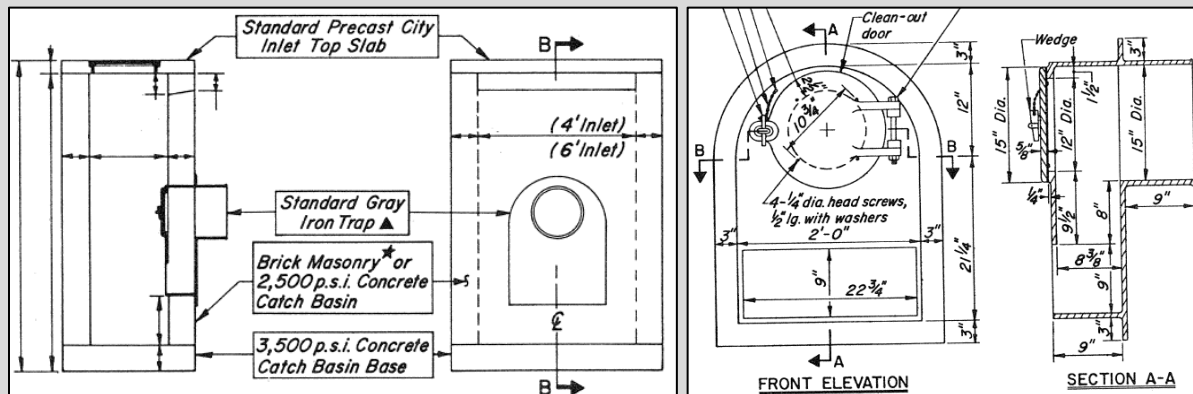

Figure 3 – Inlet with Cast Trap and Cast Trap Standard Details

### Catch Basin Depth Measurement

If the inlet is constructed with a solid trap wall, the lateral invert depth must be estimated by calculating its depth based on a measurement to the bottom of the catch basin. An estimated depth is used because measuring the exact inlet lateral invert depth would require removal of the trap wall. This method employs a tool for locating the bottom of the inlet catch basin and a tape measure for gathering the depth measurement. When locating the catch basin bottom, PWD Inlet Cleaning uses a long rigid pole to push through any floatables and grit accumulated in the catch basin.

1. Locate and measure depth to catch basin bottom – Extend the measuring tool as deep into the inlet catch basin as possible. It is possible that floatable debris and grit may be within the catch basin and require some application of force to reach the catch basin bottom. After noting the point along this pole where the top of the dripstone (BC) is, remove the pole from the inlet and measure the distance between the end and that point. The measured distance will be the depth to the catch basin bottom.
2. Calculate the estimated depth of the inlet lateral invert – From the depth to the catch basin bottom the inlet lateral invert depth can be estimated by subtracting twenty-two inches (22"). This estimated difference between the catch basin bottom and the inlet lateral invert was determined by PWD Inlet Cleaning after taking a series of measurements at various inlets around the City and should be considered an estimate only.

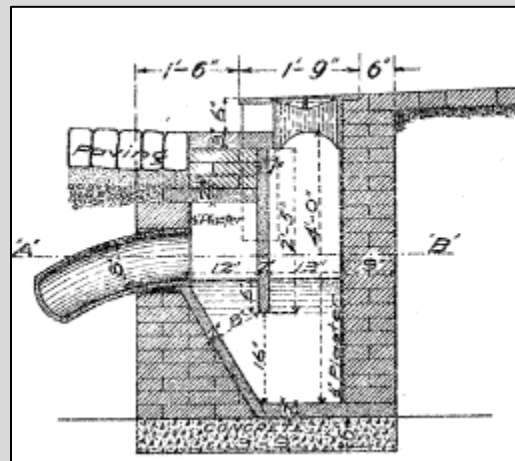

Figure 4 – Inlet with Solid Trap Wall Standard Detail

### **2.1.6 Cross Sections for On-Street Surveys**

1. A cross section is needed at proposed green inlet locations based on proposed system layouts in planning package. Typically, this is five (5) feet upstream of an existing inlet.
2. Show all utilities in the entire cartway and both footways to the house lines. Show all abandoned utilities as well.
3. Show adjacent slopes or walls in the cross section.
4. Show basement depth of adjacent properties in cross sections. Assume 8-foot depth for the properties with unknown basement depth.
5. Where there is a railroad bridge shown on the baseplan, show a cross section of the railroad bridge with underside elevations on the baseplan (this is in addition to the standard cross section for the baseplan).
6. City Plan information, where it deviates from existing, should be shown with a dashed line.

## 2.2 Drainage Area Information Survey Requirements

### 2.2.1 Extents & Elevations

1. Drainage area information may be gathered either by survey or by City Plan information without field survey, depending on the availability of information.
2. Survey may be required where City Plan is not available electronically or where actual elevations differ from City Plan by more than six (6) inches. Where survey information is used:
  - a. Collect sufficient information to determine the limits of the contributing drainage area.
  - b. Continue at least 50 feet in all direction past the limits of the contributing drainage area.
  - b. Provide surveyed locations for existing features as described below.
  - c. List the survey benchmark in the upper corner obtained from the Streets Department Survey District.

### 2.2.2 City Plan Information

1. Show curb and right-of-way (ROW) lines from City Plan. Where the curb differs from City Plan or does not exist, show the City Plan curb line as a dashed line.
2. Label the extents of ROW distance and angles.
3. Label block lengths/distances. Label should be placed adjacent to the ROW line.
4. Label all street grades, with label shown along the gutter.
5. Include cartway and footway width dimensions in both plan and sections.
6. Label street, including State Route numbers. If the street is not legally open, reflect in the street callout.
7. City Plan elevations at all corners and mid-block change in grades.
  - a. Assume the survey elevations are to City Plan if the existing elevations are within six (6) inches of the City Plan data.
  - b. If the survey elevations are different than City Plan by more than six (6) inches, show both the existing street elevation and City Plan elevations.
  - c. Place arrow heads on the curb pointing in the direction of stormwater flow.

### 2.2.3 End of Drainage Area Information

1. Identify the feature that terminates the drainage area with an appropriate callout such as “END OF DRAINAGE AREA: RIDGE”.
2. Identify a mid-block high point with labeled elevations for both the top of curb and gutter for both sides of the cartway.
  - a. At a 25-foot offset to either side of this high point, provide labeled elevations for both the top of curb and gutter elevations for both sides of the cartway.
  - b. Callout the mid-block high point as “END OF DRAINAGE AREA: MID BLOCK HIGH POINT”.
  - c. Include high point as a spot elevation if separate from the centerline of the street.
3. Identify any inlet that terminates the drainage area with the inlet type and labeled elevations for both the top of curb and gutter at the inlet.
  - a. If at the end of a block, ensure that both the inlet and the entire intersection are shown.
  - b. Callout the inlet as “END OF DRAINAGE AREA: INLET”.

#### Field Observations – Look out for:

- ✓ Signs of significant ponding due to paving or curbing deterioration.
- ✓ Large contributing drainage areas such as parking lots or adjacent impervious surfaces.

## 3.0 DRAWING REQUIREMENTS

### 3.1 General Requirements

#### 3.1.1 Drawing Size

1. All drawings must be on 30"x42" paper and conform to the *PWD Water & Sewer Design Manual* requirements except where noted below. See *Appendix F* for example plans.
  - a. Sheet...30" x 42"
  - b. Outer Border...29" x 41" (1/2" from top, bottom, right, and left)
  - c. Inside Border...27" x 39" (1" from top, bottom, right, and left)
  - d. Title Block...5" x 9" in lower right corner

#### 3.1.2 Drawing Scales

1. Draft the location plans at an appropriate scale to fit the site content and maintain legibility.
2. Draft the baseplans at a 1"=10' scale, as detailed site plans are required to be submitted at this scale, or as approved by the PWD project manager. Sheets should be cut in a manner consistent with proposed systems layouts to reduce the setup of the project sheets.
  - a. **Exception:** Centralized GSI Facility projects may be drafted at a different scale. Generally, scales should be no smaller than 1:30 for legibility.
3. Draft the landscape plans at a scale no greater than 1"=10' (so the detail of the planting design can be easily readable), unless otherwise specified by the PWD project manager. 1/4"=1' is acceptable for smaller systems such as planters or bumpouts as long as the viewport shows enough contextual information to identify the location of the SMP. Each system should be shown on its own sheet with its corresponding plant schedule. Do not combine more than one system on a sheet or have one single plant schedule for multiple systems.
4. Draft the sections at a 1/4" = 1'-0" scale or as otherwise appropriate and as approved by the PWD project manager.
5. Draft the profiles/elevation views at a 1"=5' vertical scale and a 1"=10' horizontal scale or as otherwise appropriate and as approved by the PWD project manager.

#### 3.1.3 Plan Presentation

1. The Design Consultant's name or company logo should be included to the left of the title block on each sheet.
2. List the completion date directly below the Design Consultant's company name or logo. At each submission ensure that this date is updated to aid in version tracking.
3. During design development, label plans in accordance with their design phase:
  - a. Preliminary Design
  - b. Substantially Complete Design
  - c. Pre-Final Design
4. Final plans are to be stamped by a registered Professional Engineer in the State of Pennsylvania.
5. Provide the following on each drawing above the title block as shown in the *PWD Water & Sewer Design Manual*:
  - a. Ward number
  - b. Sewer Plat Number
  - c. Highway District Number
  - d. Streets Survey District Number

- e. One Call Serial Number
  - f. Outfall Number (if applicable)
6. Work numbers are to conform to the requirements outlined in *Section 1 Project Initiation* of the *PWD Water & Sewer Design Manual*. For GSI projects, work numbers should be given the prefix of (S) and the suffix of (G), for example: S-50100-G.
7. Page numbers are to be as follows:
  - a. T – Index Sheet
  - b. G – Green Sheets including plan, section, and profile views and all detail sheets
  - c. L – Landscape Sheets including details (may not be part of final bid set\*)
  - d. DA – Drainage Area Sheets (not for construction\*)
8. In plan view, orient the primary street horizontally across the sheet, with the north arrow oriented up in reference to the horizontal line.
9. Show connecting plan sheets with appropriate use of match lines.
10. Proposed legend must be included on all sheets.
11. Plan view, sections, and profiles/elevation views should generally be included on the same sheet for all systems.
12. For elevation views, which show a system in profile but include system components at multiple layers, the components should be drafted relative to the street center line.
13. For centralized GSI facility projects, order GSI sewer sheets such that they follow the flow pattern of the sewer to the GSI system.
13. Include a representative cross-section for every system and at all street crossings. Sections should ideally be located at the deeper end of system, particularly when located adjacent to structures, or where there are complicated configurations.
14. Show basement depth of adjacent properties in cross sections. Assume 8-foot depth for the properties with unknown basement depth. The bottom of property and its respective bearing zone should be removed at PS&E and Final Design phase.
15. In cross sections and profile/elevation views, show 2V:1H sewer zone of influence line as well as the projection lines that define limits of impermeable geomembrane liner. These lines should be removed at PS&E and Final Design phase.
15. Confirm location of section with PWD project manager prior to drafting.
16. Show actual ADA ramp location and design layout submitted to Streets Department ADA Unit including accurate placement of detectable warning surface (DWS) and landing area.
17. Show geomembrane liner and geotextile configuration of the system in plan and section views. Profile/elevation views should not show any information on liner/geotextile.
18. Do not show overhead wires on G sheets. Should only be on baseplan and landscape sheets.
19. Abandoned utilities and stubbed laterals may be removed from design plans if they make the plan too crowded and are located outside of proposed area of excavation. Confirm with PWD project manager before removing.

**Note on Plan Clarity:**

Designers should attempt to minimize overall plan clutter on all sheets. Particular attention should be paid to overlapping lines, text, and symbols. In cases where the proposed callouts are difficult to read, drafters should utilize background masking.

**Note on Landscape Plans and Drainage Area Sheets:**

PWD typically completes landscaping through a separate landscaping contract. If landscaping is done by this separate contract, then the landscape plans should not be part of the construction documents for the general construction project. Instead, the landscape plans should be provided as a separate drawing set and should not be included in the numbering of the general bid set.

Drainage Area sheets are required for PWD reference and are integrated into PWD's GIS asset tracking system. However, Drainage Area sheets are not part of the construction drawings and should not be included in the numbering of the general bid set.

### 3.2 Symbology & Labeling

#### 3.2.1 General

1. Standard PWD GSI symbols and labeling must be used to the maximum extent feasible. See *Sections 3.2.2 and 3.2.3 below and Appendix A.*
2. If features are owned and/or maintained by entities other than PWD, ownership must be added to all relevant callouts or otherwise distinguished through a note on the plans.

#### 3.2.2 System & SMP Numbering

PWD uses a unique numbering methodology to identify GSI assets. The numbering begins on the design plans and in the design metrics report and is carried over to PWD’s GIS asset tracking system and green metrics tracking database (GreenIT).

1. System labels are composed of the project ID and the system number in the format: [Project ID]-[System Number].
2. SMP labels are composed of the SMP type, the project ID, system number, and SMP number in the format: [SMP Type] [Project ID]-[System Number]-[SMP Number].
3. SMP types included in the labeling must conform to PWD’s standard list of SMP types defined in the [GreenIT Design Report Definitions](#).
4. Labels should be bold and prominently displayed. See example in *Figure 5* below.

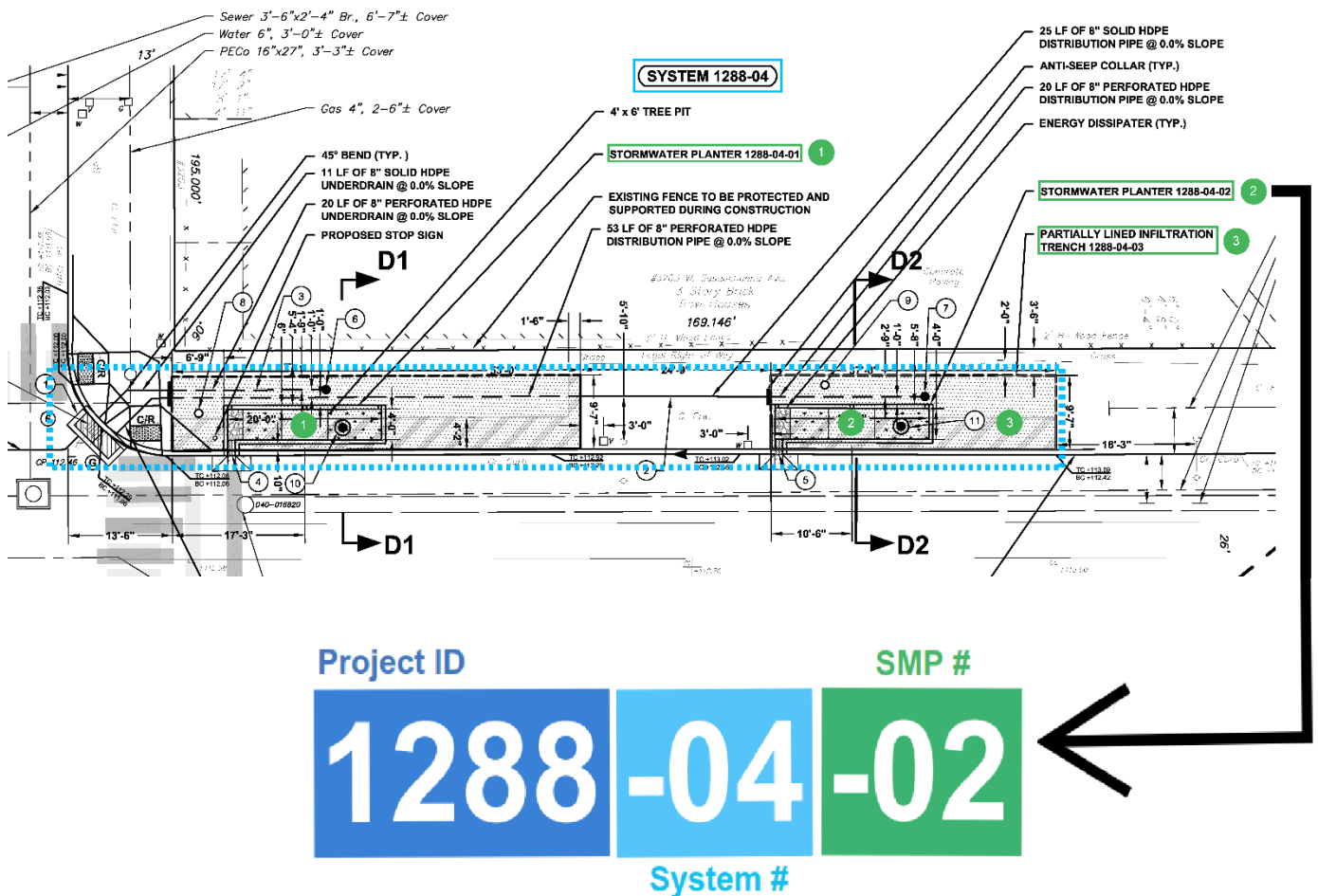

Figure 5 – Example SMP and system labels



### 3.2.3 Maintenance Component IDs

PWD uses a unique numbering methodology to identify GSI components, such as inlets, pipes, cleanouts, observation wells, and other structures. Similar to the system and SMP numbering, the component IDs are subsequently carried over to PWD’s GIS asset tracking system. See *Appendix A* for templates of component ID callouts. *Figure 6* below provides an example of how these IDs are presented on a design plan.

1. The Design Consultant should show an empty component ID table on the Preliminary Design, Substantially Complete Design, and first PS&E Design submissions.
2. Numbers are assigned by the PWD Green Stormwater Operations (GSO) Group. GSO marks up the design plans with the appropriate component IDs during PS&E design review once PWD project manager confirms components are finalized.
3. Once received, the Design Consultant should incorporate these mark-ups into the pre-final and final plan sets.
4. Component IDs are typically included in a tabular format on the design sheets.

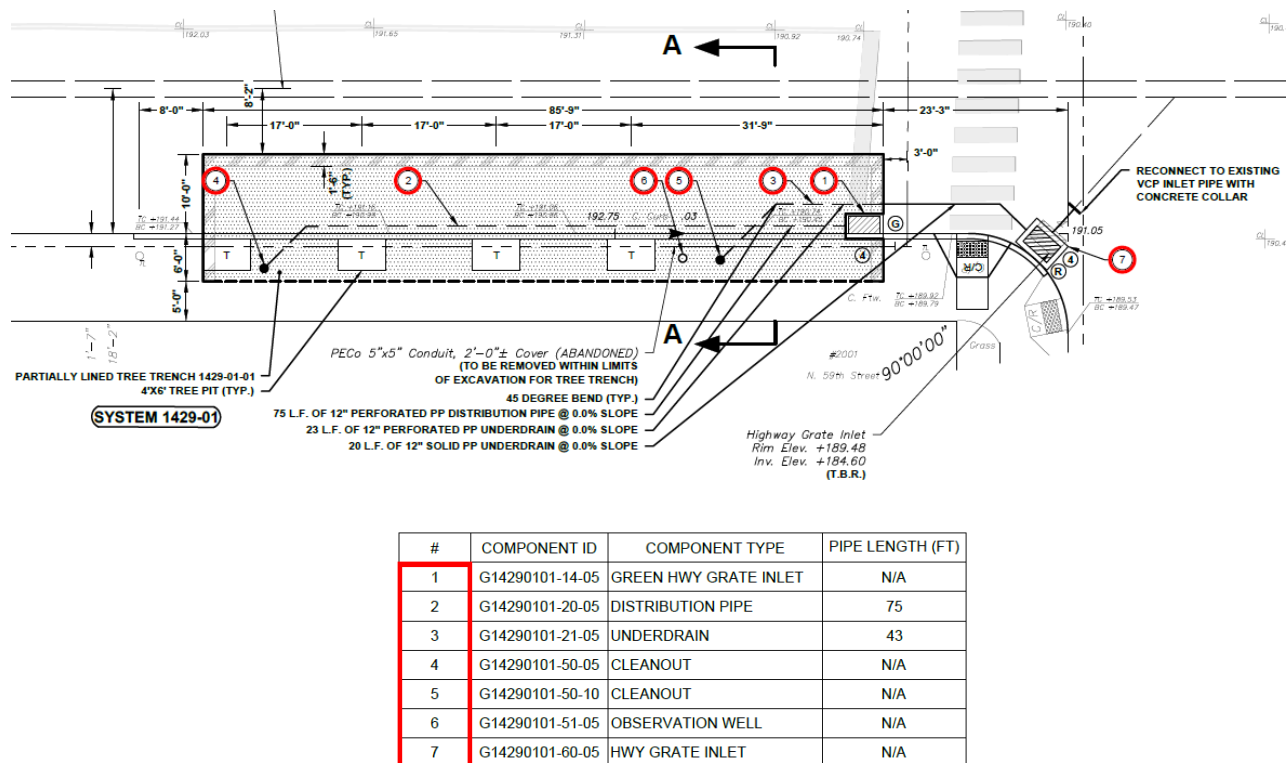

Figure 6 – Example Maintenance Component IDs 1 through 7 with reference table

### 3.3 Dimensions & Elevations

Comprehensive dimensioning of GSI plans is critical to achieving accurate construction and calculation of green storage metrics. Designers should ensure that sufficient dimensions are provided to determine compliance with design requirements.

1. All controlling and designed elevations must be dimensioned in section or profile/elevation view, as appropriate. Refer to standard callouts in *Appendix A* for more information on required elevations. To reduce the potential for inconsistency within the plan set, elevations should not be presented in plan view unless they are related to grading plans in which case grade elevations for new sidewalk and paving including direction and cross-slopes should be shown on plan view.
2. Lengths and widths of all proposed items must be dimensioned in plan view from a fixed reference point. The standard reference point is the Point of Intersection (PI) as the curbline is more permanent than other street features.
3. Distance between tree pits should be shown from center of pit to center of pit where tree will be planted.
4. Include dimensions of horizontal offsets from existing street features (utility poles, hydrants, laterals, buildings, fences, property line, etc.) that impact the location for proposed work.

### 3.4 Landscape Plans

1. Use abbreviations when labeling plants and include a translation table with additional information.
2. Use a simple key for abbreviations by using the first letter of the genus and the first letter of the species for each plant, capitalizing both letters. Example: A red maple tree, *Acer rubrum*, would be represented with the key "AR". If a key happens to be the same for multiple plants, use either of the following:
  - a. Add the next letter that does not conflict from the species to the end of the key (example: *Acer rubrum* (AR) and *Agasache rupestris* (ARP)), or
  - b. If there are two of the same species and one is a cultivar/variety, use the first letter of the cultivar/variety (example: *Acer rubrum* (AR) and *Acer rubrum* 'Armstrong' (ARA)).
3. Label trees with a Tree Location ID callout
  - a. S#####-## = tree pit in trench system, VS#####-## = vegetated system tree, NS#####-## = non-system tree, where ##### is the Project ID and ## indicates the tree location.
  - b. Tree Location ID can also be included as column in the plant schedule for clarity. See example landscape plans for further guidance.
4. Display plant schedule for all plants proposed with the following columns in the translation table, separated by vegetation type (i.e. trees, shrubs, grasses, herbaceous, seeding):
  - a. Hatch Pattern (if applicable)
  - b. Key
  - c. Common Name
  - d. Botanical Name
  - e. Quantity
  - f. Size
  - g. Spacing
  - h. Overhead Wires (list if overhead wires are present above the proposed trees)
  - i. Sun/Shade (list the light conditions of the area in which the plant is located, not the species light requirements).
  - j. Comments

5. In the comments section of the plant schedule, list critical site constraints or design considerations related to the selection of the species and/or cultivars. This information is useful to include so PWD can more easily make thoughtful substitutions to align with the original intent of the landscape design. Examples of comments include: single versus multi-stem trees, height or form characteristics specifically chosen with a certain cultivar, male or female cultivars for pollination, etc. *Note: Substitutions frequently occur when certain species are unavailable at local nurseries or if seasonal planting restrictions affect the species that are specified for a project.*
6. The size of plants listed in the plant schedule must match standards of the nursery trade. For example: Single stem B&B trees are typically sold in a range of caliper size, such as “2 - 2½”, rather than given as an exact measurement. Refer to the Chapter 5: Landscape Design Requirements in the *GSI Landscape Design Guidebook* for further clarification.
7. If a project includes both GSI and non-GSI (non-system) plants on the landscape plan, then separate plant schedules should be created to reflect the system and non-system plants. This typically only applies to partner projects where non-GSI improvements are being made in conjunction with the PWD GSI systems.
8. Polygons must be used to outline massings of herbaceous plants, grass species, seed mixes, and plugs. Each polygon should have a callout with the quantity of species in the massing. Polygons next to each other should not overlap. The quantity for each species massing must correlate with its spacing noted in the planting schedule.
  - a. Example: “JE (22)” would note *Juncus effusus* (Common Rush) in a massing of twenty-two plants.
  - b. Each polygon should be filled with a unique hatch for each species and incorporated into the plant schedule for each species.
9. Connecting leader lines may be used to label groups of shrubs and/or trees.
10. Tree blocks should not be used for tree trenches in order to reduce clutter. Tree pits already indicate the tree location.
11. The extent of stone storage areas under plantings must be shown.
12. If soil depths vary throughout the system, then this should be accurately depicted in the G-series of the construction document set through plan, section, and profile/elevation views.
  - a. Example: If two feet of soil is used throughout the majority of a system, but trees are being incorporated into specific areas, then G-series sheets must clearly show that the soil depth changes from 2-feet to 3-feet beneath where the trees will be planted.
  - b. Further dimensioning and annotations may be needed to show this information accurately.
13. For surface features, contours should be shown on landscape plans. This helps to show the bottom of basin and ponding elevations to better evaluate the species that will be inundated during various storms.
14. Overhead utilities, energy dissipaters, and other pertinent design features that will be visible on the surface of a system when construction is complete should be shown on landscape plans. Adjacent structures such as buildings, walls, utility poles, and existing trees should also be shown for reference. The standard design legend can be used to identify the features to prevent cluttering the landscape plans with additional callouts.

## 4.0 CAD STANDARDS

This section presents applicable standards and guidance for the preparation of GSI contract plans, utilizing AutoCAD software. The objectives of the CAD standards are to promote uniformity in the presentation of GSI contract plans by establishing a general CAD format and outlining detailed information which is required for the preparation of complete GSI drawings. The CAD standards build upon the standards set forth in the *Water & Sewer Design Manual* and Drawings Requirements outlined in *Section 3.0* by providing standard electronic templates for baseplan and design plans, linetypes, plot styles, callouts, and a block library that adhere to these requirements.

Tips and advice are included for accessing files and working in the AutoCAD environment with the developed templates. It is understood that Computer Aided Design (CAD) users have many different drafting preferences. This is not intended to teach users how to use AutoCAD, however it has been developed to explain how the templates and supporting files are setup and advises users how to manage and use the files in an efficient manner. Ultimately, the means and methods of drafting are left to the discretion of the end user.

Furthermore, it is understood that CAD users have customized options and customized file support paths for saving files such as plot styles, linetypes, shape files, etc. Therefore, it is assumed that the end user will understand where to save the provided support files.

### 4.1 CAD Platforms to Utilize

PWD requires AutoCAD 2013 or AutoCAD Civil 3D 2013 and later to be utilized. Figures within this document and supplemental resource files have been created using AutoCAD 2018. Note that PWD recommends drafting in AutoCAD rather than AutoCAD Civil 3D when working in files for which the three-dimensional functionality of Civil 3D is not needed, as AutoCAD Civil 3D is generally slower and more taxing on the available resources of the user's computer. Refer to *Section 4.4 Deliverables and Data Exchange*, for more information pertaining to deliverables to the Department.

### 4.2 Templates

Templates are supplied with pre-loaded styles and layers corresponding to two stages of plan preparation: baseplan and design plan. Templates are also provided for the standard PWD title block and typical GSI index sheet. All AutoCAD drawings should be created on the appropriate template.

#### 4.2.1 Title Block

Plan sheets are to be plotted with the standard title block. The overall title block consists of three files, a sheet layout containing line work and data that will remain constant on all plan sheets and two attribute blocks that must be placed on and edited for each individual plan sheet for the sheet titles and additional signature lines. PWD recommends that the sheet layout be externally referenced into paper space so that any changes made to the sheet layout will be carried out on all plan sheets. The templates are designed to accept the sheet layout and attribute block references at a base point of 0,0,0. For additional detail on setting up drawing sheets and plotting, see *Appendix E*.

#### 4.2.2 Index Sheet

The index sheet template is preloaded with layers and text styles and displays all information that is required to be shown on a typical index sheet including Project Title, Location Map, signature lines, etc. Refer to *Appendix F* to see a sample index sheet.

#### 4.2.3 Baseplan

The baseplan template is pre-loaded with layers, text styles, multileader styles, and dimension styles that display and identify site survey existing features. All linework should be drawn on the correct layers.

#### 4.2.4 Design Plan

The design plan template is pre-loaded with layers, text styles, multileader styles, dimension styles, and table styles that associate with proposed features. All linework should be drawn on the correct layers.

### 4.3 Graphic Concepts and Standards

The objective of establishing CAD graphical standards is to ensure contract documents conform to a widely recognized format. This conformance creates consistency between PWD projects and phases executed by varied Design Consultants and aids in the construction phase as well as post-construction management, operations, and maintenance.

#### 4.3.1 Working Units

The standard working units for drawing files are shown in *Table 1* below. PWD expects that drawings be set to the specified working units for deliverables to PWD or exchanged between Design Consultants in such circumstances where, for example, the baseplan is created by a different Design Consultant than the design phase plan.

Table 1 - Standard Working Units

| Baseplan |                 |           | Design Plan |                 |           |
|----------|-----------------|-----------|-------------|-----------------|-----------|
| Type     | Unit            | Precision | Type        | Unit            | Precision |
| Linear   | Engineering     | 0.00      | Linear      | Engineering     | 0.00      |
| Angular  | Decimal Degrees | 0.0       | Angular     | Decimal Degrees | 0.0       |

#### 4.3.2 Standard Scales

All model space geometry must be drawn to actual size (1:1 ratio) in model space. The standard scales for paper space scaling and annotation are shown in *Table 2*. These scales have been pre-loaded into the templates. Be advised that many of the annotation scales have been pre-set, thus the particular naming convention of the scales must be followed.

Table 2 - Standard Scales

| Scale     | Use                        | Scale      | Use                  |
|-----------|----------------------------|------------|----------------------|
| 1" = 1"   | ---                        | 1" = 50'   | ---                  |
| 1" = 1'   | ---                        | 1" = 60'   | ---                  |
| 1/8" = 1' | Baseplan Section           | 1" = 100'  | Project Location Map |
| 1/4" = 1' | Baseplan or Design Section | 1" = 200'  | Project Location Map |
| 1" = 10'  | Plan View, Elevation View  | 1" = 500'  | Project Location Map |
| 1" = 20'  | Location Plan, Plan View   | 1" = 1000' | Project Location Map |
| 1" = 30'  | Location Plan              | 1" = 2000' | ---                  |
| 1" = 40'  | Location Plan              | 1" = 5000' | ---                  |

### 4.3.3 User Coordinate System (UCS)

When working on larger systems or hydraulically connected systems at street intersections, rotate the plan view of a drawing to be able to convey the design information appropriately. Rather than rotate the plan in “model-space” (which should never be done) or rotate the viewport in paper space, users should apply a user coordinate system (UCS) for displaying plans at various orientations. The use of UCS is important because the native coordinate system of the drawing(s) is maintained at all times. Furthermore, the blocks developed for this standard have been created to automatically rotate and scale based on the UCS orientation and scale. Note that since it is common to insert external references or other block references that may contain coordinate data, users should pay special attention to what UCS view they are in when inserting said references and ensure that “World” coordinate system is selected.

### 4.3.4 Annotative Text for Plan View

Annotative text will be utilized for all plan view text, dimensions, and multileaders shown at multiple scales. Annotative text will scale up or down based on the annotation scale of the drawing. Annotation scales for text to be shown at multiple scales on the plan sheets will be set to the appropriate scales for deliverables and exchanges between Design Consultants. Plans should show all text, dimensions and callouts at 1”-10’ for plan view and either 1”-20’ or 1”-30’ for the location plan. See *Appendix C* for a reference of the required plotted text heights. It should be noted that the standard callouts for profile/elevation view are not annotative and are set to plot at the correct height when scaled at 1”-10’ Horizontal Scale and 1”=5’ vertical scale.

### 4.3.5 Text/Dimension/Table/Multileader Styles

Each template described in Section 4.2 above includes pre-set styles for text, dimensions, tables and multileaders. Styles for items shown in both the location plan and plan view are annotative but require that the annotation scales be defined for each object created from that style.

### 4.3.6 Blocks (Standard and Dynamic)

This standard has been created to use standard and dynamic blocks. The blocks are designed to streamline drafting and give the user options for different design scenarios. Some blocks utilize attributes to allow users to edit/add/remove text within a block without corrupting the integrity of the block as it is referenced elsewhere within the same drawing. Furthermore, the dynamic functionality of select blocks adds flexibility and intelligence to the geometry through the use of custom grips and properties.

*Appendix A* contains an entire visual list of standard and dynamic blocks developed for this standard. The blocks are intended to be used during the baseplan and design phases of a project. Two block libraries have been developed: one for baseplans and the other for design plans.

Rather than copy and paste blocks from one drawing to another, it is strongly encouraged to save the block libraries locally on a user’s computer and reference them through AutoCAD’s Design Center. Saving the block libraries to a network drive has been known to cause lag and non-responsiveness in AutoCAD. To access the design center, type “DC” in the command line and press enter. From there you can navigate to the block libraries and select the appropriate block to be inserted. *Appendix E* contains tips on how to access the blocks through the design center.

Inside of the block libraries, users will also find standardized callouts to ensure consistency in how PWD GSI is identified in baseplans and design plans. Users should cut and paste the callouts from the respective block library file. The callouts are not accessible through the Design Center. Refer to *Appendix A* for the full inventory of standardized callouts.

#### **4.3.7 Plot Style, Page Setup and Plotting**

The templates have been designed to be compatible with a single plot style. The templates have been preset to use the developed plot style. It is the responsibility of end users to save the provided plot style at an appropriate location on their local hard drive or network drive for AutoCAD to map it properly. Instructions for plotting can be found in *Appendix E*. The *PWD GSI CAD Standards Support File Instructions for AutoCAD* document, included with the CAD templates, has instructions for adding PWD's support files to Windows' default AutoCAD support file location.

#### **4.3.8 External Referencing**

This standard requires that external referencing be utilized as different project stages (baseplan and design plan) exist as separate AutoCAD drawing files. For example, external referencing allows the baseplan to be underlain in the model space of the design plan so that it may be viewed alongside the proposed design. In addition, each project should utilize external referencing for setting up drawing layouts. Layouts should be created in a separate drawing file with design stages externally referenced into the model space. These drawings should not contain any other entities in model space. Layouts should externally reference the project's title block and border. See *Appendix E* for steps to externally reference files.

### **4.4 Deliverables and Data Exchange**

Any exchange of contract documents in the form of electronic data between PWD and the Design Consultant will occur via one of the options indicated below.

#### **4.4.1 File Sharing**

Design Consultants are to use PWD's Water Engineering External Documents (WEXD) SharePoint site as the primary method for delivering/receiving electronic files. Conventional e-mail may be used for smaller files.

#### **4.4.2 Additional Required File Formats**

AutoCAD files (.dwg) must be submitted so that all external references are either maintained and mapped properly or bided prior to submission to PWD. This must be accomplished through the use of the "Etransmit" command in AutoCAD. The "Etransmit" command is the required method as this allows for image and PDF references to be included, as well as plot-style settings. See *Appendix E* for instructions to "Etransmit" a project.

In addition to the AutoCAD files, the Design Consultant is required to deliver a corresponding PDF file set replicating each contract plan sheet generated for each review submission. All PDF files must be representative prints at a resolution of 300 DPI that replicates the full-size sheet of Arch E1 (30" x 42").

## 4.5 File Naming Convention and Standard Reference Files

The following file naming convention will be used for all drawing files. This includes the layout drawing, external reference drawings and external reference images. Layout drawings, the drawing that contains only layout sheets and external references, should adhere to the naming convention in *Table 3*.

**Table 3 – Layout Drawing Naming Convention**

| PWD Contract Number | Site/Project Name | File Purpose   | Extension |
|---------------------|-------------------|--|-----------|
| X - ##### - XXXX    | _XXXXX            | _Baseplan Layout<br>_Preliminary Design Layout<br>_Substantially Complete Design Layout<br>_Final Design Layout<br>_Landscape Layout<br>_Erosion Control Layout<br>_Title Block Layout | .dwg      |

External reference drawings should follow the naming convention shown in *Table 4*.

**Table 4 – External Reference Drawing Naming Convention**

| PWD Contract Number | Site/Project Name | File Purpose*  | Extension |
|---------------------|-------------------|--|-----------|
| X - ##### - XXXX    | _XXXXX            | _Baseplan XREF<br>_Preliminary Design XREF<br>_Substantially Complete Design XREF<br>_Final Design XREF<br>_Landscape XREF<br>_Erosion Control XREF<br>_Title Block XREF | .dwg      |

\*Additional “File Purpose” names are acceptable when necessary.

External reference images should follow the naming convention shown in *Table 5*.

**Table 5 – External Reference Images Naming Convention**

| PWD Contract Number | Site/Project Name | File Purpose*            | Extension                      |
|---------------------|-------------------|--------------------------|--------------------------------|
| X - ##### - XXXX    | _XXXXX            | _Aerial<br>_Map<br>_Plan | .tiff<br>.jpeg<br>.dwf<br>.pdf |

\*Additional “File Purpose” names are acceptable when necessary.

## 4.6 Layer Naming Convention

The provided templates aim to provide all necessary layers, but additional layers may be required on a per project basis. When adding additional layers, care should be taken to keep layer names under 25 characters long. Abbreviations may be used where appropriate. The layer naming convention illustrated in *Table 6* provides guidance for naming additional layers when needed.

**Table 6 – Layer Naming Convention**

| GIS (Optional)* | Prefix/Discipline | Category (Optional)     | Feature | Sub-Type (Optional) |
|-----------------|-------------------|-------------------------|---------|---------------------|
| GIS-            | EX-<br>G-         | PROF-<br>UTIL-<br>TEXT- | XXXXX   | -TEXT<br>-HATCH     |

\*Some layers may require Geographic Information System (GIS) database exportation. The GIS- prefix allows for these layers to be queried and imported to a GIS program.



## **APPENDIX A: CALLOUT AND BLOCK LIBRARY**

# CALLOUT VARIABLES



The callout library was created to be applicable to numerous proposed and existing features in a green stormwater infrastructure project. This table has been created to assist the user in determining the appropriate information to complete these callouts for a specific project. Callout variables are typically enclosed within angle brackets, "<" and ">" and the contents describe the information that the user will insert. In cases where the user is expected to insert a numeric value, the letter "X" is used as a placeholder. Callouts are to be cut and paste from the block library file into design template files as needed. Callouts are not accessible through the Design Center.

Different levels of detail are displayed using callouts in the various views shown on a project plan sheet. Generally location plans show only existing feature callouts. Plan views show existing feature callouts along with proposed features callouts omitting detailed design information. Profiles and sections views include more design details for proposed features such as elevations.

| Variable             | Possible Values  |   |
|----------------------|--|---|
| X,XXX                | <ul style="list-style-type: none"> <li>• Drainage Area (SF)</li> </ul>   |   |
| XXXX-XX              | <ul style="list-style-type: none"> <li>• System Number</li> </ul>  |   |
| XXXX-XX-XX           | <ul style="list-style-type: none"> <li>• SMP Number</li> </ul>   |   |
| +XX.XX               | <ul style="list-style-type: none"> <li>• Elevation</li> </ul>  |   |
| <PLAN SHEET>         | <ul style="list-style-type: none"> <li>• T-XX</li> <li>• G-XX</li> <li>• L-XX</li> <li>• DA-XX</li> </ul>  |   |
| <SURFACE TYPE>       | <ul style="list-style-type: none"> <li>• PERVIOUS</li> </ul>   | <ul style="list-style-type: none"> <li>• IMPERVIOUS</li> </ul>  |
| <SMP TYPE>           | <ul style="list-style-type: none"> <li>• BASIN</li> <li>• BLUE ROOF</li> <li>• BUMP-OUT</li> <li>• DEPAVING</li> <li>• DRAINAGE WELL</li> <li>• GREEN GUTTER</li> <li>• GREEN ROOF</li> <li>• INFILTRATION/STORAGE TRENCH</li> </ul> | <ul style="list-style-type: none"> <li>• INLET DISCONNECTION</li> <li>• PERVIOUS PAVING</li> <li>• STORMWATER PLANTER</li> <li>• RAIN GARDEN</li> <li>• STORMWATER TREE</li> <li>• SWALE</li> <li>• TREE TRENCH</li> <li>• WETLAND</li> </ul> |
| <LINER>              | <ul style="list-style-type: none"> <li>• FULLY LINED</li> </ul>  | <ul style="list-style-type: none"> <li>• PARTIALLY LINED</li> </ul>   |
| <INLET STYLE>        | <ul style="list-style-type: none"> <li>• HWY GRATE INLET</li> <li>• CITY INLET</li> <li>• OMG INLET</li> <li>• GREEN CITY INLET W/ APRON</li> <li>• GREEN HIGHWAY GRATE INLET</li> </ul>   | <ul style="list-style-type: none"> <li>• GREEN SHALLOW CITY INLET W/ APRON</li> <li>• GREEN DUAL CATCH BASIN CITY INLET W/ APRON</li> <li>• GREEN DUAL CATCH BASIN HWY GRATE INLET</li> <li>• OTHER (Custom Inlets)</li> </ul>                |
| <CONSTRUCTION NOTES> | <ul style="list-style-type: none"> <li>• TO BE ABANDONED</li> <li>• TO BE PROTECTED AND SUPPORTED</li> <li>• TO BE PROTECTED</li> <li>• TO BE RELOCATED</li> </ul>   | <ul style="list-style-type: none"> <li>• TO BE REMOVED</li> <li>• TO BE REMOVED AND RESET</li> <li>• TO BE RESTORED</li> <li>• OTHER</li> </ul>   |
| <SEWER STYLE>        | <ul style="list-style-type: none"> <li>• RCP</li> <li>• Brick</li> </ul>   | <ul style="list-style-type: none"> <li>• VCP</li> <li>• TCP</li> </ul>  |
| <PIPE MATERIAL>      | <ul style="list-style-type: none"> <li>• DI</li> <li>• RCP</li> <li>• RCEP</li> <li>• PVC</li> </ul>   | <ul style="list-style-type: none"> <li>• VCP</li> <li>• HDPE</li> <li>• PP</li> </ul>   |
| <UTILITY NAME>       | <ul style="list-style-type: none"> <li>• Water</li> <li>• Sewer</li> <li>• Storm Sewer</li> <li>• PECo</li> <li>• Gas</li> </ul>   | <ul style="list-style-type: none"> <li>• Verizon</li> <li>• SEPTA</li> <li>• Steam</li> <li>• Sinclair Refinery Line</li> </ul>   |
| <TOP>                | <ul style="list-style-type: none"> <li>• TC</li> <li>• GRATE</li> </ul>  | <ul style="list-style-type: none"> <li>• RIM</li> </ul>   |
| <CONNECTION>         | <ul style="list-style-type: none"> <li>• &lt;SMP TYPE&gt;</li> <li>• OTHER</li> </ul>  | <ul style="list-style-type: none"> <li>• &lt;INLET STYLE&gt;</li> </ul>   |
| <UNDERDRAIN>         | <ul style="list-style-type: none"> <li>• X/X" ORIFICE</li> </ul>   | <ul style="list-style-type: none"> <li>• SOLID CAP</li> </ul>   |

# BASEPLAN BLOCK LIBRARY

## PLAN VIEW - EXISTING UTILITY CALLOUTS

-  Gas X", X'-X" Cover
-  Water X", X'-X" Cover
-  PECO X"xX" Conduit, X'-X" Cover
-  Verizon X"xX", X'-X" Cover
-  SEPTA X", X'-X" Cover
-  Sewer X" Dia. <SEWER STYLE>, X'-X" Cover
-  Sanitary Sewer X" Dia. <SEWER STYLE>, X'-X" Cover
-  Storm Sewer X" Dia., X'-X" Cover
-  Steam X" Dia., X'-X" Cover
-  Sinclair Refinery Line X", X'-X" Cover
-  Unk. Utility X", X'-X" Cover
-  Gas X", X'-X" Cover (ABANDONED)
-  Water X", X'-X" Cover (ABANDONED)
-  PECO X"xX" Conduit, X'-X" Cover (ABANDONED)
-  Verizon X"xX", X'-X" Cover (ABANDONED)
-  SEPTA X", X'-X" Cover (ABANDONED)
-  Sewer X" Dia. <SEWER STYLE>, X'-X" Cover (ABANDONED)
-  Sanitary Sewer X" Dia. <SEWER STYLE>, X'-X" Cover (ABANDONED)
-  Storm Sewer X" Dia., X'-X" Cover (ABANDONED)
-  Steam X" Dia., X'-X" Cover (ABANDONED)
-  Sinclair Refinery Line X", X'-X" Cover (ABANDONED)
-  Stubbed Sewer Lateral (Typ.)





# BASEPLAN BLOCK LIBRARY

## SECTION - EXISTING UTILITY CALLOUTS

- 
- Gas X", X'-X" Cover
  - Water X", X'-X" Cover
  - PECo X"xX" Conduit, X'-X" Cover
  - Verizon X"xX", X'-X" Cover
  - SEPTA X", X'-X" Cover
  - Sewer X" Dia. <SEWER STYLE>, X'-X" Cover
  - Sanitary Sewer X" Dia. <SEWER STYLE>, X'-X" Cover
  - Storm Sewer X" Dia., X'-X" Cover
  - Steam X" Dia., X'-X" Cover
  - Sinclair Refinery Line X", X'-X" Cover
  - Unk. Utility X", X'-X" Cover
  - Gas X", X'-X" Cover (ABANDONED)
  - Water X", X'-X" Cover (ABANDONED)
  - PECo X"xX" Conduit, X'-X" Cover (ABANDONED)
  - Verizon X"xX", X'-X" Cover (ABANDONED)
  - SEPTA X", X'-X" Cover (ABANDONED)
  - Sewer X" Dia. <SEWER STYLE>, X'-X" Cover (ABANDONED)
  - Sanitary Sewer X" Dia. <SEWER STYLE>, X'-X" Cover (ABANDONED)
  - Storm Sewer X" Dia., X'-X" Cover (ABANDONED)
  - Steam X" Dia., X'-X" Cover (ABANDONED)
  - Sinclair Refinery Line X", X'-X" Cover (ABANDONED)

# BASEPLAN BLOCK LIBRARY



## EXISTING INLET AND MANHOLE CALLOUTS

|  |  |
|--|--|
|  <p>&lt;INLET STYLE&gt; (No. X)<br/>         &lt;TOP&gt; Elev. +XX.XX<br/>         Inv. Out Elev. +XX.XX</p>                          |  <p>Manhole<br/>         Rim Elev. +XX.XX<br/>         Inv. Elev. +XX.XX (+XX.XX SRE)</p>   |
|  <p>Manhole<br/>         Rim Elev. +XX.XX<br/>         Inv. Elev. +XX.XX (+XX.XX SRE)<br/>         Inv. Elev. +XX.XX (+XX.XX SRE)</p> |  <p>Manhole<br/>         Rim Elev. +XX.XX<br/>         Inv. Elev. +XX.XX (+XX.XX SRE) N<br/>         Inv. Elev. +XX.XX (+XX.XX SRE) S<br/>         Inv. Elev. +XX.XX (+XX.XX SRE) E<br/>         Inv. Elev. +XX.XX (+XX.XX SRE) W</p> |

## SURFACE TYPE CALLOUTS













|                |                   |            |            |        |
|----------------|-------------------|------------|------------|--------|
| C. Curb        | Bituminous Paving | Gravel     | Gr. Ftw.   | S.R.L. |
| Blue St. Curb  | Concrete Paving   | Mulch      | Sl. Ftw.   | S.R.E. |
| Dep. Curb      | Macadam Paving    | Asph. Ftw. | Br. Gutter |        |
| Gr. Curb       | Dirt              | C. Ftw.    | D/W        |        |
| Asphalt Paving | Grass             | Br. Ftw.   | C. Alley   |        |

## SITE FEATURE CALLOUTS









|  |  |  |
|--|--|--|
| Br. Wall   | C. Pad   | Bench  |
| St. Wall   | Ramp   | X' High <Insert Type> Fence  |
| C. Wall  | Window Well  | X' High <Insert Type> Wall   |
| Gate   | Vacant Lot   | X Story <Insert Type> Row House  |
| Parking Lot  | #<Insert Lot No.>  | X Story <Insert Type> Building   |
|  <p>TC +XX.XX<br/>BC +XX.XX</p> |  <p>TS +XX.XX<br/>BS +XX.XX</p> |  <p>+XX.XX</p> |

# DESIGN PLAN BLOCK LIBRARY

## PLAN VIEW - EXISTING UTILITY CALLOUTS











-  Gas X", X'-X" Cover
-  Water X", X'-X" Cover
-  PECO X"xX" Conduit, X'-X" Cover
-  Verizon X"xX", X'-X" Cover
-  SEPTA X", X'-X" Cover
-  Sewer X" Dia. <SEWER STYLE>, X'-X" Cover
-  Stubbed Sewer Lateral (Typ.) (**<CONSTRUCTION NOTES>**)
-  Sanitary Sewer X" Dia. <SEWER STYLE>, X'-X" Cover
-  Storm Sewer X", X'-X" Cover
-  Steam X" Dia., X'-X" Cover
-  Sinclair Refinery Line X", X'-X" Cover
-  Unk. Utility X", X'-X" Cover
-  <UTILITY NAME> X", X'-X" Cover (ABANDONED)  
(**<CONSTRUCTION NOTES>**)

## PLAN VIEW - EXISTING FEATURES CALLOUTS

-  Traffic Sign (**<CONSTRUCTION NOTES>**)
-  Stop Sign (**<CONSTRUCTION NOTES>**)
-  Fire Hydrant (**<CONSTRUCTION NOTES>**)
-  Grass Strip (**<CONSTRUCTION NOTES>**)
-  Tree (**<CONSTRUCTION NOTES>**)
-  <INLET STYLE> (No. X)  
<TOP> Elev. +XX.XX  
Inv. Out Elev. +XX.XX  
(**<CONSTRUCTION NOTES>**)
-  PC
-  PI
-  PT

# DESIGN PLAN BLOCK LIBRARY

## PLAN VIEW - SMP CALLOUTS

-  <LINER> <SMP TYPE> XXXX-XX-XX
-  EARTHEN SPILLWAY  
X' WIDE, +XX.XX CREST ELEV.
-  ENERGY DISSIPATER (TYP.)
-  X'xX' TREE PIT (TYP.)
-  TRAFFIC DELINEATOR (TYP.), PLACED AT XX' O.C.
-  DEPRESSED CURB  
BC ELEV. +XX.XX
-  DEPRESSED CURB W/ WHEEL GUARD  
BC ELEV. +XX.XX
-  ORNAMENTAL FENCE
-  CONCRETE CURB WITH INTEGRAL  
CHARCOAL COLORING
-  PLANTER WALL WITH INTEGRAL  
CHARCOAL COLORING

# DESIGN PLAN BLOCK LIBRARY

## PLAN VIEW - COMPONENT LABELING

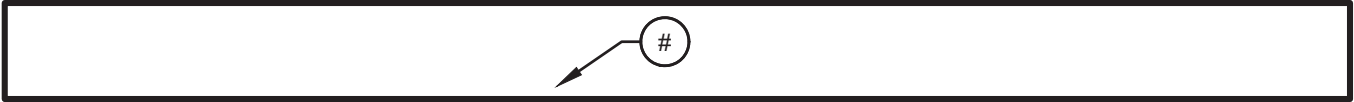

## PLAN VIEW - LANDSCAPING CALLOUTS

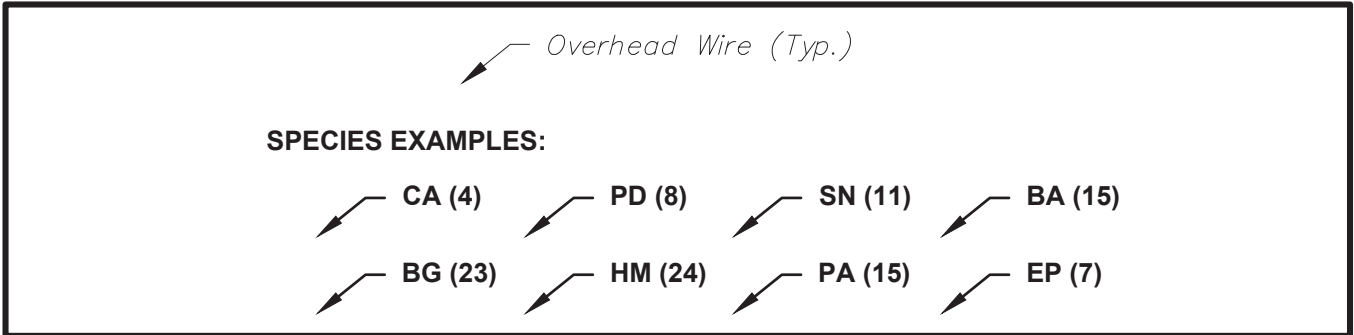

## PLANVIEW - PROPOSED FEATURES CALLOUTS

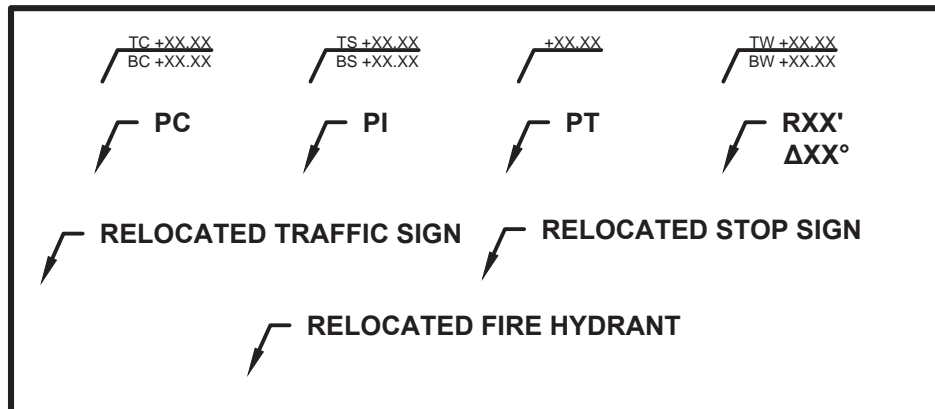



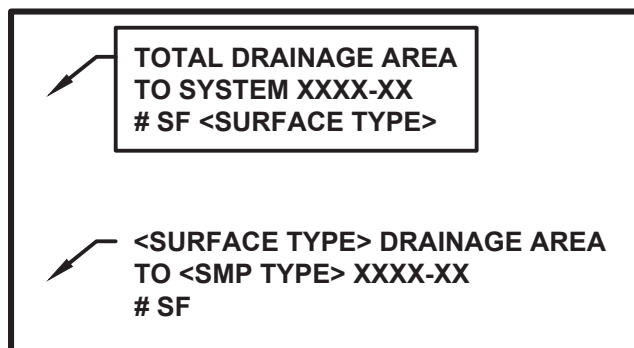











## DRAINAGE AREA CALLOUT





# DESIGN PLAN BLOCK LIBRARY

## PLAN VIEW - SMP PIPE CALLOUTS





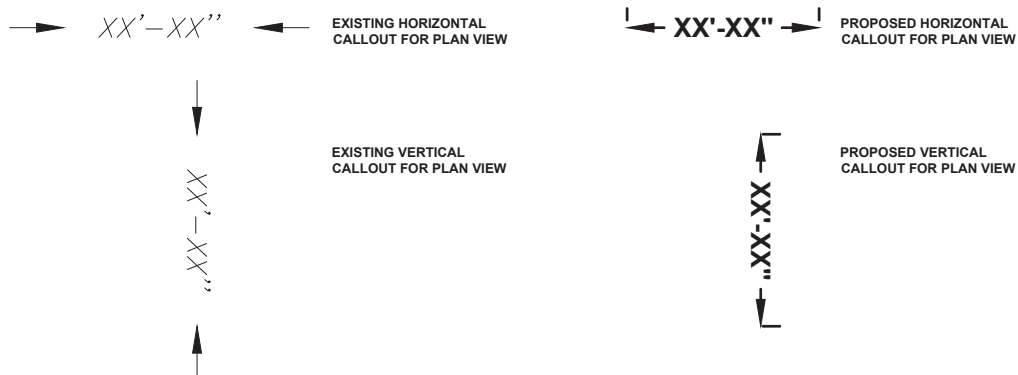













-  ANTI-SEEP COLLAR (TYP.)
-  XX° BEND (TYP.)
-  # LF OF X" SOLID <PIPE MATERIAL> UNDERDRAIN @ X.X% SLOPE
-  # LF OF X" SOLID <PIPE MATERIAL> DISTRIBUTION PIPE @ X.X% SLOPE
-  # LF OF X" PERFORATED <PIPE MATERIAL> UNDERDRAIN @ X.X% SLOPE
-  # LF OF X" PERFORATED <PIPE MATERIAL> DISTRIBUTION PIPE @ X.X% SLOPE
-  X" <PIPE MATERIAL> WYE FITTING
-  X'-X" VERTICAL DROP OVER X'-X" LENGTH
-  X'-X" VERTICAL RISE OVER X'-X" LENGTH
-  X" TO X" FLEXIBLE COUPLING (TYP.)
-  # LF OF 15" VCP LATERAL W/ SADDLE CONNECTION TO SEWER
-  # LF OF 15" VCP LATERAL W/ WYE CONNECTION TO SEWER
-  RECONNECT TO EXISTING VCP INLET PIPE WITH CONCRETE COLLAR
-  # LF OF X" <PIPE MATERIAL> GSI SEWER, X'-X"± COV. @ X.X% SLOPE

## PLAN VIEW - DIM. STYLES



# DESIGN PLAN BLOCK LIBRARY











## PROFILE - EXISTING UTILITY CALLOUTS

-  Gas X", X'-X" Cover
-  Water X", X'-X" Cover
-  PECO X"xX" Conduit, X'-X" Cover
-  Verizon X"xX", X'-X" Cover
-  SEPTA X", X'-X" Cover
-  Sewer X" Dia. <SEWER STYLE>, X'-X" Cover
-  Stubbed Sewer Lateral (Typ.) (**<CONSTRUCTION NOTES>**)
-  Sanitary Sewer X" Dia. <SEWER STYLE>, X'-X" Cover
-  Storm Sewer X", X'-X" Cover
-  Steam X" Dia., X'-X" Cover
-  Sinclair Refinery Line X", X'-X" Cover
-  Unk. Utility X", X'-X" Cover
-  <UTILITY NAME> X", X'-X" Cover (ABANDONED)  
(**<CONSTRUCTION NOTES>**)
-  X:X Projection
-  2:1 Zone of Influence
-  Bearing Zone
-  <UTILITY NAME> Lateral
-  <UTILITY NAME> X", X'-X" Cover  
(**<CONSTRUCTION NOTES>**)

**NOTE: PROFILE CALLOUT TEXT IS SIZED AT HALF HEIGHT AND DOUBLE WIDTH IN ORDER TO DISPLAY CORRECTLY AT 1"=5' VERTICAL SCALE AND 1"=10' HORIZONTAL SCALE.**

# DESIGN PLAN BLOCK LIBRARY











## PROFILE - EXISTING FEATURES CALLOUTS

-  Utility Pole (<CONSTRUCTION NOTES>)
-  Light Pole (<CONSTRUCTION NOTES>)
-  SEPTA Pole (<CONSTRUCTION NOTES>)
-  Traffic Sign (<CONSTRUCTION NOTES>)
-  Stop Sign (<CONSTRUCTION NOTES>)
-  Traffic Light (<CONSTRUCTION NOTES>)
-  Tree (<CONSTRUCTION NOTES>)
-  X' High <Insert Type> Fence/Wall  
(<CONSTRUCTION NOTES>)
-  <INLET STYLE> (No. X)  
<TOP> Elev. +XX.XX  
Inv. Out Elev. +XX.XX  
(<CONSTRUCTION NOTES>)
-  <INLET STYLE> (No. X)  
<TOP> Elev. +XX.XX  
**X" IN INV. ELEV. +XX.XX**  
**CORED INTO INLET WITH <UNDERDRAIN>**  
**FROM <CONNECTION>**  
Inv. Out Elev. +XX.XX  
To Sewer

**NOTE: PROFILE CALLOUT TEXT IS SIZED AT HALF HEIGHT AND DOUBLE WIDTH IN ORDER TO DISPLAY CORRECTLY AT 1"=5' VERTICAL SCALE AND 1"=10' HORIZONTAL SCALE.**

# DESIGN PLAN BLOCK LIBRARY

## PROFILE - SMP CALLOUTS

-  STORMWATER SOIL  
TOP ELEV. +XX.XX  
BOTTOM ELEV. +XX.XX
-  CLEAN-WASHED AASHTO #57 STONE WRAPPED  
IN GEOTEXTILE ON TOP AND SIDES  
TOP ELEV. +XX.XX  
BOTTOM ELEV. +XX.XX
-  CLEAN-WASHED AASHTO #57 STONE FULLY  
WRAPPED IN GEOTEXTILE WITH  
GEOMEMBRANE ON BOTTOM AND SIDES  
TOP ELEV. +XX.XX  
BOTTOM ELEV. +XX.XX
-  CLEAN-WASHED AASHTO #57 STONE WRAPPED  
IN GEOTEXTILE AND GEOMEMBRANE AS INDICATED  
ON PLAN AND SECTION  
TOP ELEV. +XX.XX  
BOTTOM ELEV. +XX.XX
-  TOP OF STONE/GEOTEXTILE IN CARTWAY TO MATCH  
BOTTOM OF CONCRETE ROAD BASE UNTIL REACHING  
ELEV. +XX.XX
-  AASHTO #57 STONE PIPE BEDDING FOR  
SUMPED UNDERDRAIN, BOTTOM ELEV. +XX.XX
-  OBSERVATION WELL (TYP.)
-  X'xX' TREE PIT (TYP.)
-  ENERGY DISSIPATER (TYP.)
-  6" THICK SAND LAYER

**NOTE: PROFILE CALLOUT TEXT IS SIZED AT HALF HEIGHT AND DOUBLE WIDTH IN ORDER TO DISPLAY CORRECTLY AT 1"=5' VERTICAL SCALE AND 1"=10' HORIZONTAL SCALE.**

**\*THE DEFAULT LEADER HEAD IS THE FILLED TRIANGLE WHICH IS USED WHEN POINTING DIRECTLY AT AN OBJECT. A DOT LEADER HEAD IS USED WHEN POINTING TO THE INTERNAL AREA OF AN OBJECT. THE LEADER HEAD MAY BE CHANGED TO A MEDIUM DOT IN THE PROPERTIES UNDER LEADERS>ARROWHEAD>USER ARROW.**

# DESIGN PLAN BLOCK LIBRARY

## PROFILE - SMP PIPE CALLOUTS

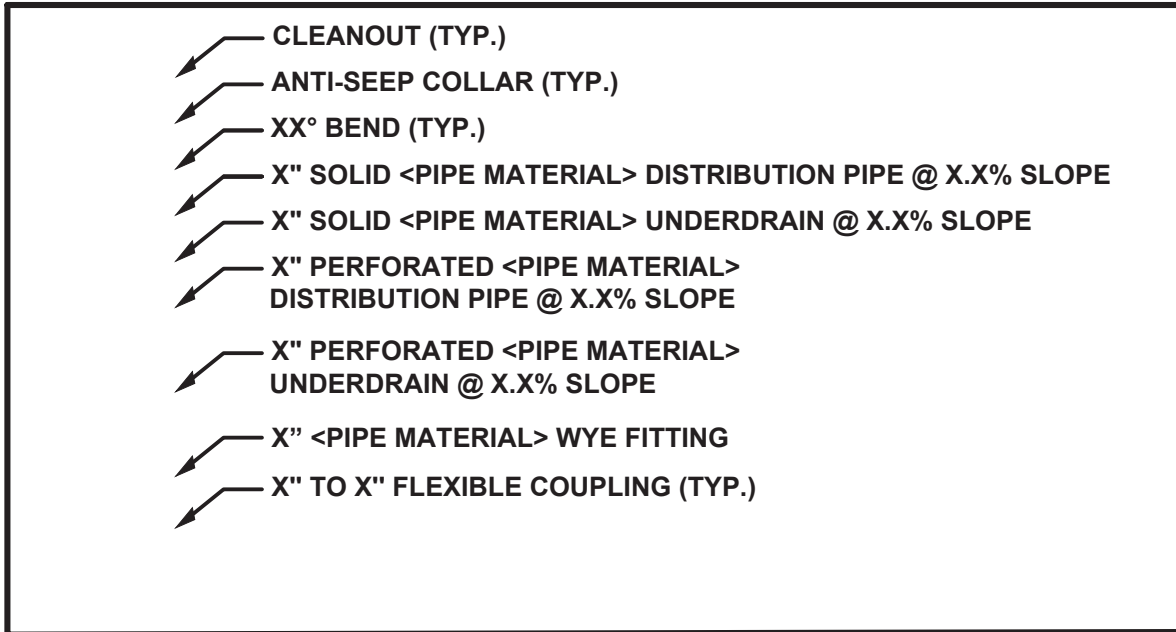

NOTE: PROFILE CALLOUT TEXT IS SIZED AT HALF HEIGHT AND DOUBLE WIDTH IN ORDER TO DISPLAY CORRECTLY AT 1"=5' VERTICAL SCALE AND 1"=10' HORIZONTAL SCALE.

## PROFILE - DIM. STYLES

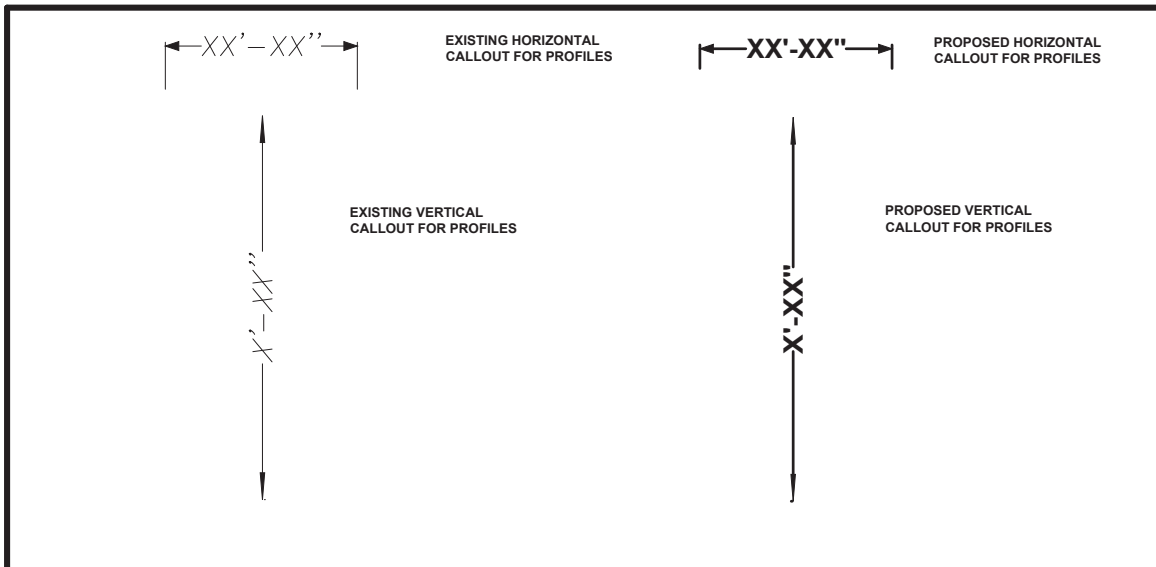

NOTE: IN ADDITION TO 1" = 10', THE DESIGN BLOCK LIBRARY CONTAINS SCALE OPTIONS FOR 1" = 20' AND 1" = 30', WHICH CAN BE USED IN CONJUNCTION WITH PLAN VIEW SCALES OF 1" = 20' OR 1" = 30' RESPECTIVELY.

# DESIGN PLAN BLOCK LIBRARY

## PROFILE - SMP INLET/SURFACE FEATURE CALLOUTS

X' <INLET STYLE>  
<TOP> ELEV. +XX.XX  
GUTTER ELEV. +XX.XX  
X" OUT INV. ELEV. +XX.XX  
TO <CONNECTION>

X' <INLET STYLE>  
<TOP> ELEV. +XX.XX  
GUTTER ELEV. +XX.XX  
X" IN INV. ELEV. +XX.XX  
FROM <CONNECTION>  
X" OUT INV. ELEV. +XX.XX  
TO <CONNECTION>

X' <INLET STYLE>  
<TOP> ELEV. +XX.XX  
GUTTER ELEV. +XX.XX  
X" IN INV. ELEV. +XX.XX  
CORED INTO INLET WITH  
<UNDERDRAIN>  
FROM <CONNECTION>  
15" OUT INV. ELEV. +XX.XX  
TO SEWER

X'xX' OVERFLOW  
CONTROL STRUCTURE  
<TOP> ELEV. +XX.XX  
X" IN INV. ELEV. +XX.XX  
CORED INTO STRUCTURE  
WITH <UNDERDRAIN>  
FROM <CONNECTION>  
X" OUT INV. ELEV. +XX.XX  
TO <CONNECTION>

XX" DOMED RISER  
RIM ELEV. +XX.XX  
X" OUT INV. ELEV. +XX.XX  
TO <CONNECTION>

XX" DOMED RISER W/ SUMP  
RIM ELEV. +XX.XX  
X" OUT INV. ELEV. +XX.XX  
TO <CONNECTION>

XX" DOMED RISER STANDPIPE  
RIM ELEV. +XX.XX

X" x X' TRENCH DRAIN W/ APRON  
<TOP> ELEV. +XX.XX  
GUTTER ELEV. +XX.XX  
X" OUT INV. ELEV. +XX.XX  
TO <CONNECTION>

SW MANHOLE  
RIM ELEV. +XX.XX  
X" IN INV. ELEV. +XX.XX  
FROM <CONNECTION>  
X" OUT INV. ELEV. +XX.XX  
TO <CONNECTION>

X'xX' JUNCTION BOX  
RIM ELEV. +XX.XX  
X" IN INV. ELEV. +XX.XX  
FROM <CONNECTION>  
X" OUT INV. ELEV. +XX.XX  
TO <CONNECTION>

WATER LEVEL CONTROL STRUCTURE  
RIM ELEV. +XX.XX  
WEIR ELEV. +XX.XX  
3" PVC CENTERLINE ELEV. +XX.XX  
WITH <UNDERDRAIN>  
X" IN INV. ELEV. +XX.XX  
FROM <CONNECTION>  
X" OUT INV. ELEV. +XX.XX  
TO <CONNECTION>



















HEADWALL  
TW ELEV. +XX.XX  
X" IN INV. ELEV. +XX.XX  
FROM <CONNECTION>

<INLET STYLE>  
<TOP> ELEV. +XX.XX  
GUTTER ELEV. +XX.XX  
WEIR ELEV. +XX.XX  
X" IN INV. ELEV. +XX.XX  
FROM <CONNECTION>  
X" IN INV. ELEV. +XX.XX  
CORED INTO INLET WITH <UNDERDRAIN>  
FROM <CONNECTION>  
X" OUT INV. ELEV. +XX.XX  
TO <CONNECTION>  
15" OUT INV. ELEV. +XX.XX  
TO SEWER

NOTE: PROFILE CALLOUT TEXT IS SIZED AT HALF HEIGHT AND DOUBLE WIDTH IN ORDER TO DISPLAY CORRECTLY AT 1"=5' VERTICAL SCALE AND 1"=10' HORIZONTAL SCALE.

# DESIGN PLAN BLOCK LIBRARY

## SECTION - EXISTING UTILITY AND FEATURE CALLOUTS

-  Gas X", X'-X" Cover
-  Water X", X'-X" Cover
-  PECO X"xX" Conduit, X'-X" Cover
-  Verizon X"xX", X'-X" Cover
-  SEPTA X", X'-X" Cover
-  Sewer X" Dia. <SEWER STYLE>, X'-X" Cover
-  Sanitary Sewer X" Dia. <SEWER STYLE>, X'-X" Cover
-  Storm Sewer X", X'-X" Cover
-  Steam X" Dia., X'-X" Cover
-  Sinclair Refinery Line X", X'-X" Cover
-  Unk. Utility X", X'-X" Cover
-  <UTILITY NAME> X", X'-X" Cover (ABANDONED)  
(<CONSTRUCTION NOTES>)
-  X:X Projection
-  2:1 Zone of Influence
-  Bearing Zone
-  <UTILITY NAME> X", X'-X" Cover (<CONSTRUCTION NOTES>)
-  <INLET STYLE> (No. X)  
<TOP> Elev. +XX.XX  
**X" IN INV. ELEV. +XX.XX**  
**CORED INTO INLET WITH <UNDERDRAIN>**  
**FROM <CONNECTION>**  
Inv. Out Elev. +XX.XX  
To Sewer
-  X' High <Insert Type> Fence/Wall  
(<CONSTRUCTION NOTES>)
-  Grass Strip (<CONSTRUCTION NOTES>)

# DESIGN PLAN BLOCK LIBRARY

## SECTION - SMP CALLOUTS

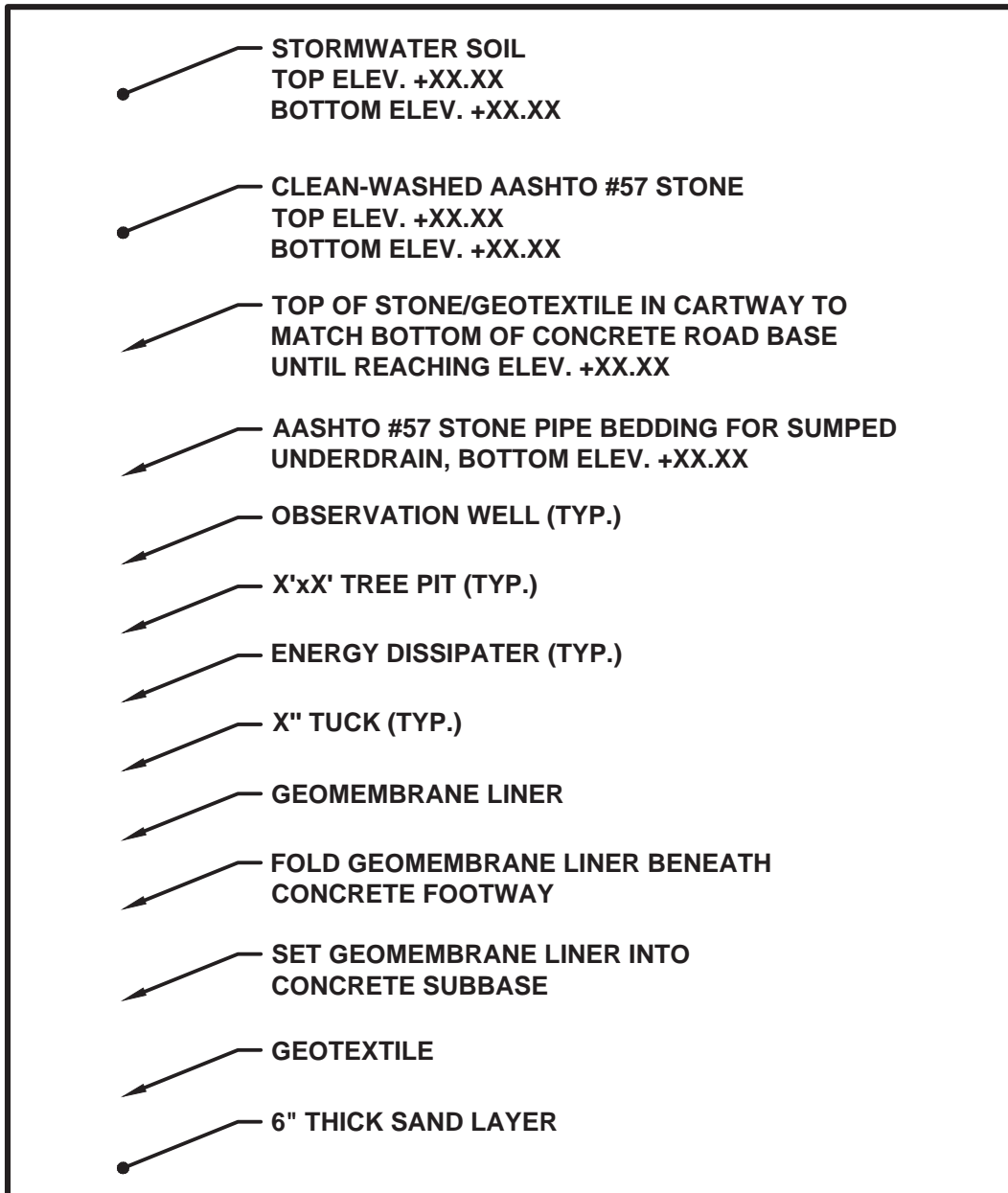

**NOTE: THE DEFAULT LEADER HEAD IS THE FILLED TRIANGLE WHICH IS USED WHEN POINTING DIRECTLY AT AN OBJECT. A DOT LEADER HEAD IS USED WHEN POINTING TO THE INTERNAL AREA OF AN OBJECT. THE LEADER HEAD MAY BE CHANGED TO A MEDIUM DOT IN THE PROPERTIES UNDER LEADERS>ARROWHEAD>USER ARROW.**



# DESIGN PLAN BLOCK LIBRARY

## SECTION - SMP PIPE CALLOUTS

 CLEANOUT (TYP.)

 ANTI-SEEP COLLAR (TYP.)

 XX° BEND (TYP.)

 X" SOLID <PIPE MATERIAL> DISTRIBUTION PIPE @  
X.X% SLOPE

 X" SOLID <PIPE MATERIAL> UNDERDRAIN @ X.X% SLOPE

 X" PERFORATED <PIPE MATERIAL> DISTRIBUTION PIPE @  
X.X% SLOPE

 X" PERFORATED <PIPE MATERIAL> UNDERDRAIN @ X.X%  
SLOPE

 X" <PIPE MATERIAL> WYE FITTING

 X" TO X" FLEXIBLE COUPLING (TYP.)

# DESIGN PLAN BLOCK LIBRARY

## SECTION - SMP INLET/SURFACE FEATURE CALLOUTS

X' <INLET STYLE>  
<TOP> ELEV. +XX.XX  
GUTTER ELEV. +XX.XX  
X" OUT INV. ELEV. +XX.XX  
TO <CONNECTION>

X' <INLET STYLE>  
<TOP> ELEV. +XX.XX  
GUTTER ELEV. +XX.XX  
X" IN INV. ELEV. +XX.XX  
FROM <CONNECTION>  
X" OUT INV. ELEV. +XX.XX  
TO <CONNECTION>

X' <INLET STYLE>  
<TOP> ELEV. +XX.XX  
GUTTER ELEV. +XX.XX  
X" IN INV. ELEV. +XX.XX  
CORED INTO INLET WITH <UNDERDRAIN>  
FROM <CONNECTION>  
15" OUT INV. ELEV. +XX.XX  
TO SEWER

X'xX' OVERFLOW  
CONTROL STRUCTURE  
<TOP> ELEV. +XX.XX  
X" IN INV. ELEV. +XX.XX  
CORED INTO INLET WITH <UNDERDRAIN>  
FROM <CONNECTION>  
X" OUT INV. ELEV. +XX.XX  
TO <CONNECTION>

XX" DOMED RISER  
RIM ELEV. +XX.XX  
X" OUT INV. ELEV. +XX.XX  
TO <CONNECTION>

XX" DOMED RISER W/ SUMP  
RIM ELEV. +XX.XX  
X" OUT INV. ELEV. +XX.XX  
TO <CONNECTION>

XX" DOMED RISER STANDPIPE  
RIM ELEV. +XX.XX

X" x X' TRENCH DRAIN W/ APRON  
<TOP> ELEV. +XX.XX  
GUTTER ELEV. +XX.XX  
X" OUT INV. ELEV. +XX.XX  
TO <CONNECTION>

SW MANHOLE  
RIM ELEV. +XX.XX  
X" IN INV. ELEV. +XX.XX  
FROM <CONNECTION>  
X" OUT INV. ELEV. +XX.XX  
TO <CONNECTION>

X'xX' JUNCTION BOX  
RIM ELEV. +XX.XX  
X" IN INV. ELEV. +XX.XX  
FROM <CONNECTION>  
X" OUT INV. ELEV. +XX.XX  
TO <CONNECTION>

WATER LEVEL CONTROL STRUCTURE  
RIM ELEV. +XX.XX  
WEIR ELEV. +XX.XX  
3" PVC CENTERLINE ELEV. +XX.XX  
WITH <UNDERDRAIN>  
X" IN INV. ELEV. +XX.XX  
FROM <CONNECTION>  
X" OUT INV. ELEV. +XX.XX  
TO <CONNECTION>

HEADWALL  
TW ELEV. +XX.XX  
X" IN INV. ELEV. +XX.XX  
FROM <CONNECTION>

<INLET STYLE>  
<TOP> ELEV. +XX.XX  
GUTTER ELEV. +XX.XX  
WEIR ELEV. +XX.XX  
X" IN INV. ELEV. +XX.XX  
FROM <CONNECTION>  
X" IN INV. ELEV. +XX.XX  
CORED INTO INLET  
WITH <UNDERDRAIN>  
FROM <CONNECTION>  
X" OUT INV. ELEV. +XX.XX  
TO <CONNECTION>  
15" OUT INV. ELEV. +XX.XX  
TO SEWER

DEPRESSED CURB  
BC ELEV. +XX.XX

DEPRESSED CURB W/ WHEEL GUARD  
BC ELEV. +XX.XX

# DESIGN PLAN BLOCK LIBRARY

## SECTION - DIM. STYLES



EXISTING HORIZONTAL  
CALLOUT FOR SECTIONS

XX'-XX''

A horizontal dimension line with arrows at both ends. The text 'XX'-XX''' is centered above the line.



EXISTING VERTICAL  
CALLOUT FOR SECTIONS

XX'-  
XX''

A vertical dimension line with arrows at both ends. The text 'XX'-  
XX''' is centered to the left of the line.



PROPOSED HORIZONTAL  
CALLOUT FOR SECTIONS

XX'-XX''

A horizontal dimension line with arrows at both ends. The text 'XX'-XX''' is centered above the line.



PROPOSED VERTICAL  
CALLOUT FOR SECTIONS

XX'-XX''

A vertical dimension line with arrows at both ends. The text 'XX'-XX''' is centered to the left of the line.

NOTE: IN ADDITION TO 1/4" = 1', THE DESIGN BLOCK LIBRARY CONTAINS SCALE OPTIONS FOR 1/8" = 1', AND 1/12" = 1', WHICH CAN BE USED IN CONJUNCTION WITH PLAN VIEW SCALES OF 1" = 20' OR 1" = 30', RESPECTIVELY.



















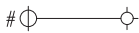

# DESIGN PLAN BLOCK LIBRARY

## EXAMPLE COMPONENT ID TABLE

| #  | COMPONENT ID | COMPONENT TYPE                             | PIPE LENGTH (FT) |
|----|--------------|--|------------------|
| 1  |              | GREEN CITY INLET W/ APRON                  | N/A              |
| 2  |              | GREEN SHALLOW CITY INLET W/ APRON          | N/A              |
| 3  |              | GREEN HWY GRATE INLET                      | N/A              |
| 4  |              | GREEN DUAL CATCH BASIN CITY INLET W/ APRON | N/A              |
| 5  |              | GREEN DUAL CATCH BASIN HWY GRATE INLET     | N/A              |
| 6  |              | GREEN DUAL CATCH BASIN OMG INLET           | N/A              |
| 7  |              | DISTRIBUTION PIPE                          | XX               |
| 8  |              | UNDERDRAIN                                 | XX               |
| 9  |              | XX" x XX' TRENCH DRAIN W/ APRON            | N/A              |
| 10 |              | CONCRETE HEADWALL W/ ENERGY DISSIPATER     | N/A              |
| 11 |              | CLEANOUT                                   | N/A              |
| 12 |              | OBSERVATION WELL                           | N/A              |
| 13 |              | SW MANHOLE                                 | N/A              |
| 14 |              | SW JUNCTION MANHOLE                        | N/A              |
| 15 |              | DOMED RISER                                | N/A              |
| 16 |              | INFILTRATION COLUMN                        | N/A              |
| 17 |              | DOMED RISER STANDPIPE                      | N/A              |
| 18 |              | HWY GRATE INLET                            | N/A              |
| 19 |              | CITY INLET                                 | N/A              |
| 20 |              | OMG INLET                                  | N/A              |
| 21 |              | WATER LEVEL CONTROL STRUCTURE              | N/A              |
| 22 |              | 2'x2' OVERFLOW CONTROL STRUCTURE           | N/A              |
| 23 |              | 2'x4' OVERFLOW CONTROL STRUCTURE           | N/A              |
| 24 |              | 2'x2' JUNCTION BOX                         | N/A              |
| 25 |              | 2'x4' JUNCTION BOX                         | N/A              |

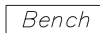
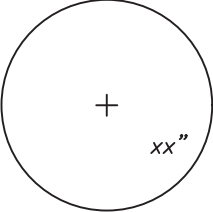













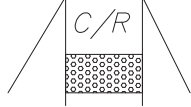



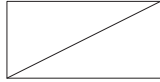

# BASEPLAN BLOCK LIBRARY

## EXISTING FEATURE LABELS





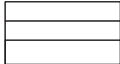

|  |   |   |   |
|--|---|---|---|
| <p><i>VENT BOX—SEWER*</i></p>         | <p><i>GAS BOX*</i></p>           | <p><i>WATER BOX*</i></p>             | <p><i>UNKNOWN CURB BOX*</i></p>    |
| <p><i>POLE*</i></p>                   | <p><i>BENCHMARK*</i></p>         | <p><i>LAMP POST*</i></p>             | <p><i>IRON POST*</i></p>   |
| <p><i>BOLLARD*</i></p>                | <p><i>PARKING METER*</i></p>     | <p><i>PE POLE</i></p>                | <p><i>TRASH RECEPTACLE*</i></p>    |
| <p><i>PE POLE W/<br/>LIGHT</i></p>  | <p><i>SEPTA POLE*</i></p>      | <p><i>TRAFFIC SIGN*</i></p>       | <p><i>TRAFFIC LIGHT*</i></p>   |
| <p><i>HEDGE</i></p>                 | <p><i>BENCH*</i></p>           | <p><i>TREE CANOPY</i></p>         | <p><i>TREE STUMP</i></p>   |
| <p><i>FIRE HYDRANT*</i></p>         | <p><i>FIRE ALARM BOX*</i></p>  | <p><i>SEPTA BUS SHELTER*</i></p>  | <p><b>*DO NOT MANUALLY ROTATE BLOCKS CONTAINING NON-ATTRIBUTE TEXT. TEXT WILL ROTATE AUTOMATICALLY TO REMAIN UPRIGHT IN ALL UCS VIEWS IN THE LAYOUT VIEWPORT. BLOCKS WITH TEXT MAY BE ROTATED WITH DYNAMIC BLOCK GRIP. SEE APPENDIX E OF THE PWD GSI SURVEY AND DRAWING STANDARDS FOR INSERTION INSTRUCTIONS.</b></p> |

# BASEPLAN BLOCK LIBRARY

## EXISTING FEATURE LABELS CONT.

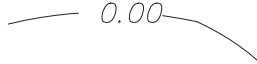
|   |   |  |   |   |
|---|---|--|---|---|
| <p>STANDPIPE*</p>            | <p>ELECTROLYSIS TEST STATION*</p>  | <p>DOOR SILL*</p>     | <p>CURB RAMP*</p>          | <p>COMPLIANT CURB RAMP</p>   |
| <p>COAL CHUTE*</p>           | <p>WINDOW GRATE</p>                | <p>DOWNSPOUT*</p>     | <p>MAIL BOX*</p>           | <p><b>*DO NOT MANUALLY ROTATE BLOCKS CONTAINING NON-ATTRIBUTE TEXT. TEXT WILL ROTATE AUTOMATICALLY TO REMAIN UPRIGHT IN ALL UCS VIEWS IN THE LAYOUT VIEWPORT. BLOCKS WITH TEXT MAY BE ROTATED WITH DYNAMIC BLOCK GRIP. SEE APPENDIX E OF THE PWD GSI SURVEY AND DRAWING STANDARDS FOR INSERTION INSTRUCTIONS.</b></p> |
| <p>CABLE TV ACCESS BOX*</p>  | <p>TRAFFIC SIGNAL CONTROLLER*</p>  | <p>PAY PHONE*</p>     | <p>PORCH</p>               |   |
| <p>STEAM GRATE*</p>        | <p>SEWER MANHOLE</p>             | <p>MANHOLE</p>      | <p>MANHOLE UNKNOWN*</p>  |   |
| <p>WATER/GAS VALVE</p>     | <p>STEPS</p>                     | <p>CELLAR DOOR</p>  | <p>SURVEY STONE*</p>     |   |

## EXISTING MISC. LABELS

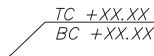
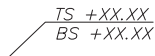
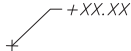
|   |  |   |   |  |
|---|--|---|---|--|
| <p>A1 </p> <p>SECTION ARROW</p>  | <p>BORING</p>       | <p>CURB FLOW ARROW</p>             | <p>EXISTING CONTOUR LABEL</p>       | <p>CENTERLINE ELEVATIONS</p>    |
| <p>A1 </p> <p>SECTION TITLE</p> <p>SECTION A - A<br/>SCALE: 1/4" = 1'-0"</p> | <p>NORTH ARROW</p>  | <p>TOP/BOTTOM OF CURB CALLOUT</p>  | <p>TOP/BOTTOM OF STEP CALLOUT</p>  | <p>EXISTING SPOT ELEVATION</p>  |

# BASEPLAN BLOCK LIBRARY









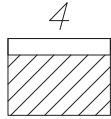
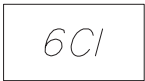
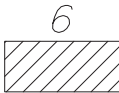
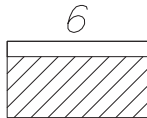

## STREET CALLOUTS

|  |   |  |  |
|--|---|--|--|
| <p><i>TWO-WAY<br/>W/PARKING</i></p> <p><b>STREET</b></p> <p>← <i>PARKING</i> →<br/>← <i>PARKING</i> →</p>  | <p><i>TWO-WAY W/ NO<br/>PARKING</i></p> <p><b>STREET</b></p> <p>← ————— →</p>   | <p><i>TWO-WAY<br/>W/PARKING ONE<br/>SIDE</i></p> <p><b>STREET</b></p> <p>← <i>PARKING</i> →</p>            | <p><i>TWO-WAY STATE<br/>ROUTE CUSTOM</i></p> <p><b>STREET<br/>(S.R. XXXX)</b></p> <p>← ————— →</p>   |
| <p><i>TWO-WAY W/ 4<br/>CUSTOM LINES AND<br/>MULTIPLE ARROW<br/>OPTIONS</i></p> <p><b>STREET</b></p> <p>← ————— →<br/>← ————— →<br/>← ————— →<br/>← ————— →</p> | <p><i>TWO-WAY W/ 4<br/>CUSTOM LINES</i></p> <p><b>STREET</b></p> <p>← ————— →<br/>← ————— →<br/>← ————— →<br/>← ————— →</p> | <p><i>ONE-WAY W/<br/>PARKING</i></p> <p><b>STREET</b></p> <p>— <i>PARKING</i> →<br/>— <i>PARKING</i> →</p> | <p><i>ONE-WAY STATE<br/>ROUTE CUSTOM</i></p> <p><b>STREET<br/>(S.R. XXXX)</b></p> <p>— ————— →<br/>— ————— →<br/>— ————— →<br/>— ————— →</p>           |
| <p><i>ONE-WAY W/ NO<br/>PARKING</i></p> <p><b>STREET</b></p> <p>————— →</p>  | <p><i>ONE-WAY W/<br/>PARKING ONE<br/>SIDE</i></p> <p><b>STREET</b></p> <p>— <i>PARKING</i> →</p>                            | <p><i>ONE-WAY W/ 4<br/>CUSTOM LINES</i></p> <p>————— →<br/>————— →<br/>————— →<br/>————— →</p>             | <p><i>ONE-WAY W/ 4<br/>CUSTOM LINES AND<br/>MULTIPLE ARROW<br/>OPTIONS</i></p> <p><b>STREET</b></p> <p>————— →<br/>————— →<br/>————— →<br/>————— →</p> |

**NOTE: BIKE LANES SHOULD BE ADDED TO STREET CALLOUTS AS NECESSARY**

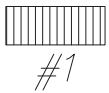
# BASEPLAN BLOCK LIBRARY

## CITY, HWY, OMG, GRATE INLETS

|   |  |  |
|---|--|--|
| <p>4' CITY</p>     | <p>4' HIGHWAY GRATE</p> <p>4</p>  | <p>4' OMG</p> <p>4</p>  |
| <p>6' CITY</p>     | <p>6' HIGHWAY GRATE</p> <p>6</p>  | <p>6' OMG</p> <p>6</p>  |
| <p>#1 CITY</p>   | <p>#2 CITY</p>                  | <p>#3 CITY</p>        |
| <p>#4 CITY</p>   | <p>#1 GRATE</p>                 | <p>#2 GRATE</p>       |
| <p>#3 GRATE</p>  | <p>#4 GRATE</p>                 |  |



# DESIGN PLAN BLOCK LIBRARY

## SECTION VIEW INLETS

|                          |                 |                |                                |                       |                               |                                       |  |
|--------------------------|-----------------|----------------|--------------------------------|-----------------------|-------------------------------|---------------------------------------|--|
| <b>HIGHWAY GRATE</b><br> | <b>CITY</b><br> | <b>OMG</b><br> | <b>GREEN HIGHWAY GRATE</b><br> | <b>GREEN CITY</b><br> | <b>GREEN SHALLOW CITY</b><br> | <b>GREEN DUAL CATCH BASIN HWY</b><br> | <b>GREEN DUAL CATCH BASIN CITY</b><br> |
|--------------------------|-----------------|----------------|--------------------------------|-----------------------|-------------------------------|---------------------------------------|--|

## PROFILE VIEW INLETS

|                          |                 |                |                                |                       |                               |                                       |  |
|--------------------------|-----------------|----------------|--------------------------------|-----------------------|-------------------------------|---------------------------------------|--|
| <b>HIGHWAY GRATE</b><br> | <b>CITY</b><br> | <b>OMG</b><br> | <b>GREEN HIGHWAY GRATE</b><br> | <b>GREEN CITY</b><br> | <b>GREEN SHALLOW CITY</b><br> | <b>GREEN DUAL CATCH BASIN HWY</b><br> | <b>GREEN DUAL CATCH BASIN CITY</b><br> |
|--------------------------|-----------------|----------------|--------------------------------|-----------------------|-------------------------------|---------------------------------------|--|

## PLAN VIEW INLETS

















|                         |                               |                         |  |   |
|-------------------------|-------------------------------|-------------------------|--|---|
| <b>4' HWY GRATE</b><br> | <b>4' GREEN HWY GRATE</b><br> | <b>6' HWY GRATE</b><br> | <b>4' CITY</b><br>                     | <b>4' GREEN CITY OR 4' GREEN SHALLOW CITY</b><br> |
| <b>6' CITY</b><br>      | <b>4' OMG</b><br>             | <b>6' OMG</b><br>       | <b>GREEN DUAL CATCH BASIN CITY</b><br> | <b>GREEN DUAL CATCH BASIN HWY</b><br>             |

## ADDITIONAL PROPOSED STRUCTURES

|  |  |  |
|--|--|--|
| <b>PROPOSED MANHOLE</b><br><b>PROFILE</b><br><br><b>SECTION</b><br><br><b>PLAN</b><br>   | <b>2'X2' OVERFLOW CONTROL STRUCTURE</b><br><b>PLAN</b><br><br><b>PROFILE</b><br><br><b>SECTION</b><br> | <b>2'X4' OVERFLOW CONTROL STRUCTURE</b><br><b>PLAN</b><br><br><b>PROFILE SECTION</b><br> |
| <b>2'X2' JUNCTION BOX</b><br><b>PLAN</b><br><br><b>PROFILE</b><br><br><b>SECTION</b><br> | <b>2'X4' JUNCTION BOX</b><br><b>PLAN</b><br><br><b>PROFILE</b><br><br><b>SECTION</b><br>               | <b>WATER LEVEL CONTROL STRUCTURE</b><br><b>PLAN</b><br><br><b>PROFILE SECTION</b><br>    |

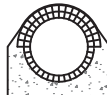
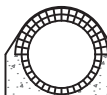

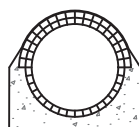
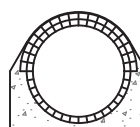
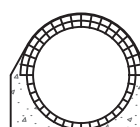



















# DESIGN PLAN BLOCK LIBRARY

## SEWER SECTION

|  |  |   |  |
|--|--|---|--|
| <p><b>EGG SHAPED</b><br/>2'-3" X 1'-6"</p>  | <p><b>EGG SHAPED</b><br/>2'-6" X 1'-8"</p>  | <p><b>EGG SHAPED</b><br/>3'-0" X 2'-0"</p>  | <p><b>EGG SHAPED</b><br/>3'-3" X 2'-2"</p>  |
| <p><b>EGG SHAPED</b><br/>3'-6" X 2'-4"</p>  | <p><b>EGG SHAPED</b><br/>4'-0" X 2'-8"</p>  | <p><b>EGG SHAPED</b><br/>4'-6" X 3'-0"</p>  | <p><b>EGG SHAPED</b><br/>5'-0" X 3'-4"</p>  |
| <p><b>CIRCULAR</b><br/>2'-0" DIA.</p>     | <p><b>CIRCULAR</b><br/>2'-3" DIA.</p>     | <p><b>CIRCULAR</b><br/>2'-6" DIA.</p>     | <p><b>CIRCULAR</b><br/>2'-9" DIA.</p>     |
| <p><b>CIRCULAR</b><br/>3'-0" DIA.</p>     | <p><b>CIRCULAR</b><br/>3'-6" DIA.</p>     | <p><b>CIRCULAR</b><br/>4'-0" DIA.</p>     | <p><b>CIRCULAR</b><br/>4'-3" DIA.</p>     |
| <p><b>CIRCULAR</b><br/>4'-6" DIA.</p>     | <p><b>CIRCULAR</b><br/>4'-9" DIA.</p>     | <p><b>CIRCULAR</b><br/>5'-0" DIA.</p>     | <p><b>VCP</b><br/>10" DIA.</p>            |

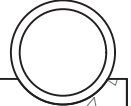
# DESIGN PLAN BLOCK LIBRARY



## SEWER SECTION CONT.

|  |  |   |  |  |
|--|--|---|--|--|
| VCP<br>12" DIA.<br>   | VCP<br>15" DIA.<br>   | VCP<br>18" DIA.<br>    | VCP<br>21" DIA.<br>   | VCP<br>24" DIA.<br> |
| VCP<br>27" DIA.<br>   | VCP<br>30" DIA.<br>   | VCP<br>36" DIA.<br>    | VCP<br>42" DIA.<br>   | RCP<br>15" DIA.<br> |
| RCP<br>18" DIA.<br> | RCP<br>21" DIA.<br> | RCP<br>24" DIA.<br> | RCP<br>27" DIA.<br> |  |
| RCP<br>30" DIA.<br> | RCP<br>36" DIA.<br> | RCP<br>42" DIA.<br> | RCP<br>48" DIA.<br> |  |
| RCP<br>54" DIA.<br> | RCP<br>60" DIA.<br> | RCP<br>66" DIA.<br> | RCP<br>72" DIA.<br> |  |

# DESIGN PLAN BLOCK LIBRARY

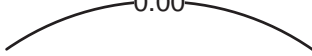
## LABELS

|   |  |  |
|---|--|--|
| <p>MATCHLINE</p> <p><b>MATCHLINE</b></p> <p>SEE SHEET G-#</p>  | <p>PROPOSED<br/>CONTOUR LABEL</p> <p>0.00</p>  | <p>SYSTEM NUMBER<br/>PLAN VIEW</p> <p><b>SYSTEM XXXX-X</b></p> |
|---|--|--|

|   |  |  |
|---|--|--|
| <p>SECTION/DETAIL TITLE</p> <p><b>SECTION A1 - A1</b></p> <p>SCALE: 1/4" = 1'-0"</p> <p><b>DETAIL NAME</b></p> <p>SCALE: N.T.S.</p> | <p><b>A1</b> ←</p>  <p>SECTION ARROW</p> <p><b>A1</b> ←</p>  | <p>INLET LABEL<br/>PLAN VIEW</p> <p>Ⓖ      Ⓓ</p> <p>④      ⑥</p> |
|---|--|--|

PROFILE TITLE

**SYSTEM XXXX-XX**

**ELEVATION VIEW**

HORIZONTAL SCALE: 1" = 10'-0"  
VERTICAL SCALE: 1" = 5'-0"

ALTERNATIVE PROFILE TITLE

**ELEVATION VIEW A1 - A1**

HORIZONTAL SCALE: 1" = 10'-0"  
VERTICAL SCALE: 1" = 5'-0"

CROSS STREET SECTION TITLE

**CROSSING ##TH ST. TO CROSS-STREET INLET ( SECTION A1 - A1 )**

SCALE: 1/4" = 1'-0"

**DESIGN PLAN NOTE FOR WORK NEAR  
OVERHEAD WIRES**













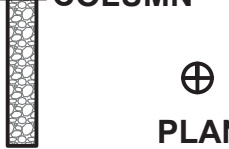
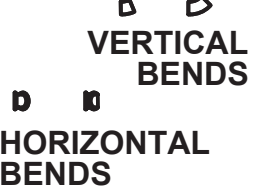





NOTE:  
OVERHEAD WIRES ON X SIDE OF X STREET.

**DESIGN PLAN NOTE FOR WORK NEAR  
TRANSMISSION MAINS**

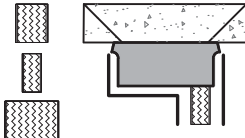
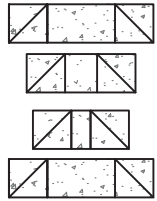
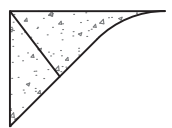

NOTE:  
THE CONTRACTOR IS ADVISED TO EXERCISE CAUTION DURING CONSTRUCTION ABOVE, BELOW, OR ADJACENT TO THE XX" WATER MAIN. SUFFICIENT CLEARANCE SHOULD BE MAINTAINED BETWEEN ANY PROPOSED PIPES AND THE EXISTING MAIN AT CROSSINGS. A FIBER OPTICATOR MUST BE PRESENT DURING THE CONSTRUCTION OF PROPOSED PIPES IN THE VICINITY OF THE EXISTING WATER MAIN. CONTRACTOR SHALL ENSURE THAT THE PIPE LENGTH DIRECTLY ABOVE THE MAIN IS CUTTERED TO MAINTAIN THE DISTANCE BETWEEN THE PROPOSED PIPE LOWES AND THE WATER MAIN. CONTRACTOR SHALL NOT STOCKPILE ANY MATERIAL ABOVE THE WATER MAIN DURING CONSTRUCTION OR OPERATE OR STORE HEAVY EQUIPMENT ABOVE THE MAIN, AND SHALL ENSURE THAT THERE IS NO REDUCTION OF COVER OVER THE MAIN OTHER THAN WHAT IS SHOWN ON THE PLANS. CONTRACTOR TO EXCAVATE BY MANUAL MEANS WITHIN 4' OF THE MAIN.

# DESIGN PLAN BLOCK LIBRARY

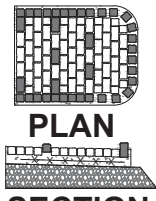
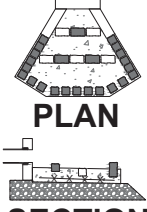
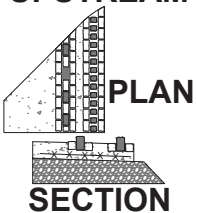
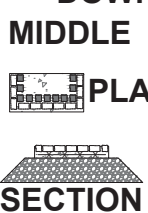

## SMP FEATURES

|  |   |  |  |   |
|--|---|--|--|---|
| <p><b>CLEANOUT</b></p>  <p>PROFILE<br/>PLAN</p>   | <p><b>12" DOMED RISER STANDPIPE</b></p>  <p>PROFILE<br/>PLAN</p> | <p><b>OBSERVATION WELL</b></p>  <p>PROFILE<br/>PLAN</p> | <p><b>INFILTRATION COLUMN</b></p>  <p>PROFILE<br/>PLAN</p> | <p><b>PIPE FITTINGS PROFILE</b></p>  <p>VERTICAL BENDS<br/>HORIZONTAL BENDS</p>  |
| <p><b>12" DOMED RISER</b></p>  <p>PROFILE<br/>PLAN</p>  | <p><b>12" DOMED RISER W/ SUMP</b></p>  <p>PROFILE<br/>PLAN</p>   | <p><b>TRAP PROFILE</b></p>                              | <p><b>TRAP SECTION</b></p>                                | <p><b>DOUBLE HORIZONTAL BENDS</b></p>  <p><b>8"X12" PIPE REDUCER</b></p>  |
| <p><b>SEWER CONNECTIONS</b></p> <p><b>RECONNECT</b></p>  <p><b>NEW CONNECTION</b></p>  | <p><b>ANTI SEEP COLLAR</b></p>  <p>PROFILE<br/>PLAN</p>          | <p><b>TRENCH DRAIN</b></p>                              | <p><b>CONCRETE APRON</b></p>                              | <p><b>CONCRETE APRON AT BUMPOUT</b></p>    |
| <p><b>WYE FITTING</b></p>  <p>PROFILE<br/>PLAN</p>  | <p><b>FLEXIBLE COUPLING</b></p>  <p>PROFILE<br/>PLAN</p>       | <p><b>SEWER VENT</b></p>  <p>PROFILE<br/>PLAN</p>     | <p><b>UTILITY SLEEVE</b></p>                            | <p><b>PROPOSED ENDWALL</b></p>  <p>PLAN<br/>PROFILE<br/>SECTION</p>  |

## ENERGY DISSIPATORS



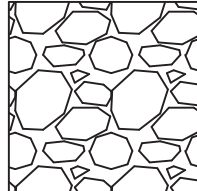
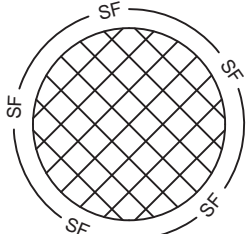

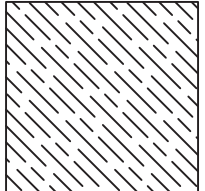

|  |   |  |  |
|--|---|--|--|
| <p><b>CURB CUT -TRENCH DRAIN</b></p>  <p>PLAN<br/>SECTION</p> | <p><b>ENDWALL</b></p>  <p>PLAN<br/>SECTION</p> | <p><b>BUMPOUT</b></p> <p><b>UPSTREAM</b></p>  <p>PLAN<br/>SECTION</p> <p><b>DOWNSTREAM</b></p>  <p>PLAN<br/>SECTION</p> <p><b>MIDDLE CORNER</b></p>  <p>PLAN<br/>SECTION</p> | <p><b>STORMWATER PLANTER</b></p>  <p>PLAN<br/>SECTION</p> |
|--|---|--|--|

## EROSION & SEDIMENTATION CONTROL





|  |  |   |   |
|--|--|---|---|
| <p><b>ROCK CONSTRUCTION ENTRANCE</b></p>  | <p><b>SOIL STOCKPILE</b></p>  | <p><b>ROCK FILTER OUTLET</b></p>  | <p><b>WOODCHIP/ PLYWOOD</b></p>  |
|--|--|---|---|

# DESIGN PLAN BLOCK LIBRARY

## SIGN, POLE, LIGHT

|   |  |   |
|---|--|---|
| <p><b>LIGHT POLE</b></p>  <p><b>PROFILE</b></p>                                      | <p><b>UTILITY POLE</b></p>  <p><b>PROFILE</b></p>                                 | <p><b>SEPTA POLE</b></p>  <p><b>PROFILE</b></p>                                    |
| <p><b>20' C-POST</b></p>  <p>OTS(20')</p> <p><b>PLAN*</b></p> <p><b>PROFILE</b></p> | <p><b>TRAFFIC SIGN</b></p>  <p>OTS</p> <p><b>PLAN*</b></p> <p><b>PROFILE</b></p> | <p><b>TRAFFIC LIGHT</b></p>  <p>OTL</p> <p><b>PLAN*</b></p> <p><b>PROFILE</b></p> |

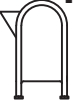



## STREET FEATURES

|   |  |  |
|---|--|--|
| <p><b>CURB RAMP LANDING OFF</b></p>  <p>C/R</p>                              | <p><b>4'x4' ADA LANDING PAD</b></p>   |  |
| <p><b>MAILBOX</b></p> <p>□ MB</p>  <p><b>PLAN*</b></p> <p><b>PROFILE</b></p> | <p><b>FIRE HYDRANT</b></p> <p>○ FH</p>  <p><b>PLAN*</b></p> <p><b>PROFILE</b></p> | <p><b>TRAFFIC DELINEATOR</b></p>  |

\*DO NOT MANUALLY ROTATE BLOCKS CONTAINING NON-ATTRIBUTE TEXT. TEXT WILL ROTATE AUTOMATICALLY TO REMAIN UPRIGHT IN ALL UCS VIEWS IN THE LAYOUT VIEWPORT. BLOCKS WITH TEXT MAY BE ROTATED WITH DYNAMIC BLOCK GRIP. SEE APPENDIX E OF THE PWD GSI SURVEY AND DRAWING STANDARDS FOR INSERTION INSTRUCTIONS.

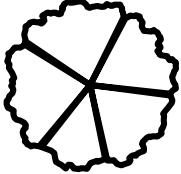
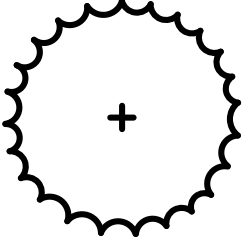
# DESIGN PLAN BLOCK LIBRARY

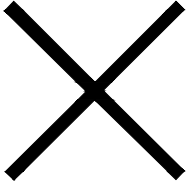



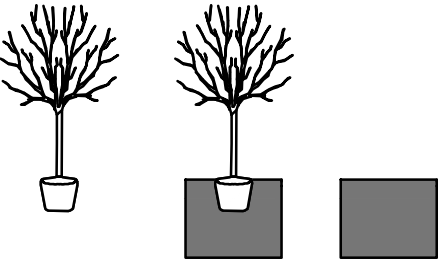
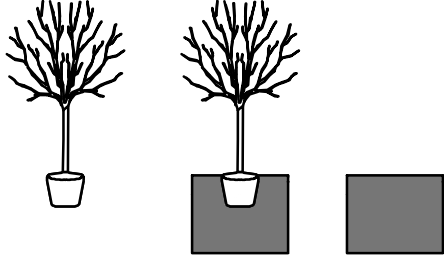

## PROPOSEED LANDSCAPING

|  |   |   |
|--|---|---|
| <p><b>DECIDUOUS TREE</b></p>      | <p><b>EVERGREEN</b></p>  | <p><b>SHRUB</b></p>    |
| <p><b>TREE TO BE REMOVED</b></p>  |   | <p><b>ORNAMENTAL FENCE PROFILE / SECTION</b></p> <div style="display: flex; justify-content: space-around;"> <div data-bbox="857 772 922 869"> <p>18"</p>  </div> <div data-bbox="1027 756 1092 869"> <p>36"</p>  </div> </div> |

## TREE PIT

|   |  |
|---|--|
| <p><b>PROFILE</b></p>  | <p><b>SECTION</b></p>  |
|---|--|

## TREE PIT PLAN VIEW

|   |   |  |   |
|---|---|--|---|
| <p><b>4' x 4'</b></p>  | <p><b>4' x 5'</b></p>  | <p><b>4' x 6'</b></p>   | <p><b>5' x 5'</b></p>  |
| <p><b>5' x 6'</b></p>  | <p><b>6' x 6'</b></p>  | <p><b>CUSTOM</b></p>  |   |

# DESIGN PLAN BLOCK LIBRARY

## PROFILE GRID

| 10 LINES    | 9 LINES     | 8 LINES     | 7 LINES     |
|-------------|-------------|-------------|-------------|
| 45 ————— 45 |             |             |             |
| 40 ————— 40 | 40 ————— 40 |             |             |
| 35 ————— 35 | 35 ————— 35 | 35 ————— 35 |             |
| 30 ————— 30 | 30 ————— 30 | 30 ————— 30 | 30 ————— 30 |
| 25 ————— 25 | 25 ————— 25 | 25 ————— 25 | 25 ————— 25 |
| 20 ————— 20 | 20 ————— 20 | 20 ————— 20 | 20 ————— 20 |
| 15 ————— 15 | 15 ————— 15 | 15 ————— 15 | 15 ————— 15 |
| 10 ————— 10 | 10 ————— 10 | 10 ————— 10 | 10 ————— 10 |
| 05 ————— 05 | 05 ————— 05 | 05 ————— 05 | 05 ————— 05 |
| 00 ————— 00 | 00 ————— 00 | 00 ————— 00 | 00 ————— 00 |
| 6 LINES     | 5 LINES     | 4 LINES     | 3 LINES     |
| 25 ————— 25 |             |             |             |
| 20 ————— 20 | 20 ————— 20 |             |             |
| 15 ————— 15 | 15 ————— 15 | 15 ————— 15 |             |
| 10 ————— 10 | 10 ————— 10 | 10 ————— 10 | 10 ————— 10 |
| 05 ————— 05 | 05 ————— 05 | 05 ————— 05 | 05 ————— 05 |
| 00 ————— 00 | 00 ————— 00 | 00 ————— 00 | 00 ————— 00 |



## APPENDIX B: LINETYPES AND HATCHING

## EXISTING LINETYPES AND HATCHING

|                       |       | LOCATION / PLAN VIEW                |       |             |
|-----------------------|-------|-------------------------------------|-------|-------------|
| ITEM                  | STYLE | LINE/ HATCH TYPE                    | SCALE | HATCH ANGLE |
| ROW LINE              | 16    | CONTINUOUS LINE                     | 1.0   | N/A         |
| EXISTING CURB LINE    | 15    | CONTINUOUS LINE                     | 1.0   | N/A         |
| PECo LINE             | 9     | PECo LINE*                          | 1.0   | N/A         |
| GAS LINE              | 9     | GAS LINE*                           | 1.0   | N/A         |
| VERIZON LINE          | 8     | VERIZON LINE*                       | 1.0   | N/A         |
| SEPTA LINE            | 9     | SEPTA LINE*                         | 1.0   | N/A         |
| SEWER LINE            | 9     | SEWER LINE*                         | 1.0   | N/A         |
| WATER LINE            | 9     | WATER LINE*                         | 1.0   | N/A         |
| SEPARATE SEWER LINE   | 9, 9  | SEWER LINE* AND SANITARY SEWER LINE | 1.0   | N/A         |
| STORM SEWER LINE      | 9     | SEWER LINE*                         | 1.0   | N/A         |
| STEAM                 | 9     | STEAM*                              | 1.0   | N/A         |
| SHRUB LINE            | 3     | SHRUBLINE                           | 1.0   | N/A         |
| PROPERTY BOUNDARY     | 8     | PROPERTY BOUNDARY*                  | 1.0   | N/A         |
| CROSSWALK/ STOP BAR   | 34    | CONTINUOUS LINE                     | 1.0   | N/A         |
| NO PARKING BOX        | 34    | CONTINUOUS LINE                     | 1.0   | N/A         |
| BUILDING LINE         | 5     | BUILDING LINE                       | 1.0   | N/A         |
| BUILDING OUTCROP LINE | 3     | CONTINUOUS LINE                     | 1.0   | N/A         |
| FENCE                 | 3     | FENCELINE*                          | 1.0   | N/A         |
| EASEMENT              | 34    | EASEMENT*                           | 1.0   | N/A         |

## EXISTING LINETYPES AND HATCHING (CONT.)

|               |       | LOCATION / PLAN VIEW |       |             |
|---------------|-------|----------------------|-------|-------------|
| ITEM          | STYLE | LINE/ HATCH TYPE     | SCALE | HATCH ANGLE |
| RAILROAD      | 26    | RAILROAD*            | 1.0   | N/A         |
| GRASS         | 32    | GRASS                | 3.5   | VARIES      |
| GSI SYSTEM    | 3     | CONTINUOUS LINE      | 1.0   | N/A         |
| OVERHEAD WIRE | 9     | OHW                  | 1.0   | N/A         |
| TOPO          | 3     | TOPO*                | 1.0   | N/A         |

**\*USER DEFINED LINETYPE.**









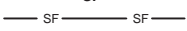
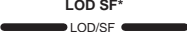

**NOTES: ALL HATCHES IN LOCATION/ PLAN VIEW SHOULD BE ANNOTATIVE. SET DISPLAY ORDER FOR ALL HATCHING TO THE BACK.**

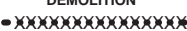
## ABANDONED UTILITY LINETYPES

|                     |       | LOCATION / PLAN VIEW                |       |             |
|---------------------|-------|-------------------------------------|-------|-------------|
| ITEM                | STYLE | LINE/ HATCH TYPE                    | SCALE | HATCH ANGLE |
| PECo LINE           | 30    | PECo LINE*                          | 1.0   | N/A         |
| GAS LINE            | 30    | GAS LINE*                           | 1.0   | N/A         |
| VERIZON LINE        | 30    | VERIZON LINE*                       | 1.0   | N/A         |
| SEPTA LINE          | 30    | SEPTA LINE*                         | 1.0   | N/A         |
| SEWER LINE          | 30    | SEWER LINE*                         | 1.0   | N/A         |
| WATER LINE          | 30    | WATER LINE*                         | 1.0   | N/A         |
| SEPARATE SEWER LINE | 30,30 | SEWER LINE* AND SANITARY SEWER LINE | 1.0   | N/A         |
| STORM SEWER LINE    | 30    | SEWER LINE*                         | 1.0   | N/A         |



## PROPOSED LINETYPES AND HATCHING (CONT.)

|                                |       | LOCATION / PLAN VIEW   |       |             | PROFILE VIEW (1" = 10')   |       |             | SECTION VIEW (1/4" = 1')  |       |             |
|--------------------------------|-------|--|-------|-------------|---|-------|-------------|---|-------|-------------|
| ITEM                           | STYLE | LINE/ HATCH TYPE   | SCALE | HATCH ANGLE | LINE/ HATCH TYPE  | SCALE | HATCH ANGLE | LINE/ HATCH TYPE  | SCALE | HATCH ANGLE |
| LIMIT OF DISTURBANCE           | 21    | LOD*<br>        | 1.0   | N/A         | N/A   | N/A   | N/A         | N/A   | N/A   | N/A         |
| SILT FENCE                     | 8     | SF*<br>         | 1.0   | N/A         | N/A   | N/A   | N/A         | N/A   | N/A   | N/A         |
| LOD/SILT FENCE                 | 21    | LOD SF*<br>     | 1.0   | N/A         | N/A   | N/A   | N/A         | N/A   | N/A   | N/A         |
| SAWCUT LINE                    | 14    | DIVIDE2<br>     | 1.0   | N/A         | N/A   | N/A   | N/A         | N/A   | N/A   | N/A         |
| DEMOLITION LINE                | 20    | DEMOLITION*<br> | 1.0   | N/A         | N/A   | N/A   | N/A         | N/A   | N/A   | N/A         |
| TREE PROTECTION ZONE           | 12    | *TPZ<br>        | 1.0   | N/A         | N/A   | N/A   | N/A         | N/A   | N/A   | N/A         |
| PROHIBITIVE ROOT ZONE          | 31    | CONTINUOUS<br>  | 1.0   | N/A         | N/A   | N/A   | N/A         | N/A   | N/A   | N/A         |
| WOODCHIP/ PLYWOOD              | 8     | GOST_WOOD<br>   | 0.03  | 45°         | N/A   | N/A   | N/A         | N/A   | N/A   | N/A         |
| BACKFILL SOIL                  | 34    | N/A  | N/A   | N/A         | EARTH<br> | 5.0   | 45°         | EARTH<br> | 5.0   | 45°         |
| BUILDING & EXPECTED FOUNDATION | 5     | N/A  | N/A   | N/A         |          | 0.3   | N/A         |          | 0.3   | N/A         |

**\*USER DEFINED LINETYPE.**

**\*\*USE STONE TRENCH TIER LINETYPE TO IDENTIFY LOCATIONS WHERE BOTTOM OF STONE ELEVATION CHANGES, EXCEPT IN LOCATIONS WHERE CHANGE IS FOR STONE BEDDING BENEATH A SUMPED PIPE.**

**NOTES: ALL HATCHES IN LOCATION/PLAN VIEW SHOULD BE ANNOTATIVE. SET DISPLAY ORDER FOR ALL HATCHING TO THE BACK.**

**THE TABLES IN THIS APPENDIX DO NOT SHOW THE LINETYPES AND COLORS ASSOCIATED WITH ALL LAYERS. EXAMPLES OF ALL LAYERS CAN BE FOUND IN THE PWD GSI BASE PLAN BLOCK LIBRARY 2021 AND THE PWD GSI DESIGN PLAN BLOCK LIBRARY 2021. ACCURATE LAYER SELECTION WILL ENSURE THAT THE PROPER LINETYPE AND COLOR ARE USED WITHOUT ANY ADDITIONAL USER ACTION.**

## **APPENDIX C: LETTERING STANDARDS AND TEXT, MULTILEADER, DIMENSION AND TABLE STYLES**

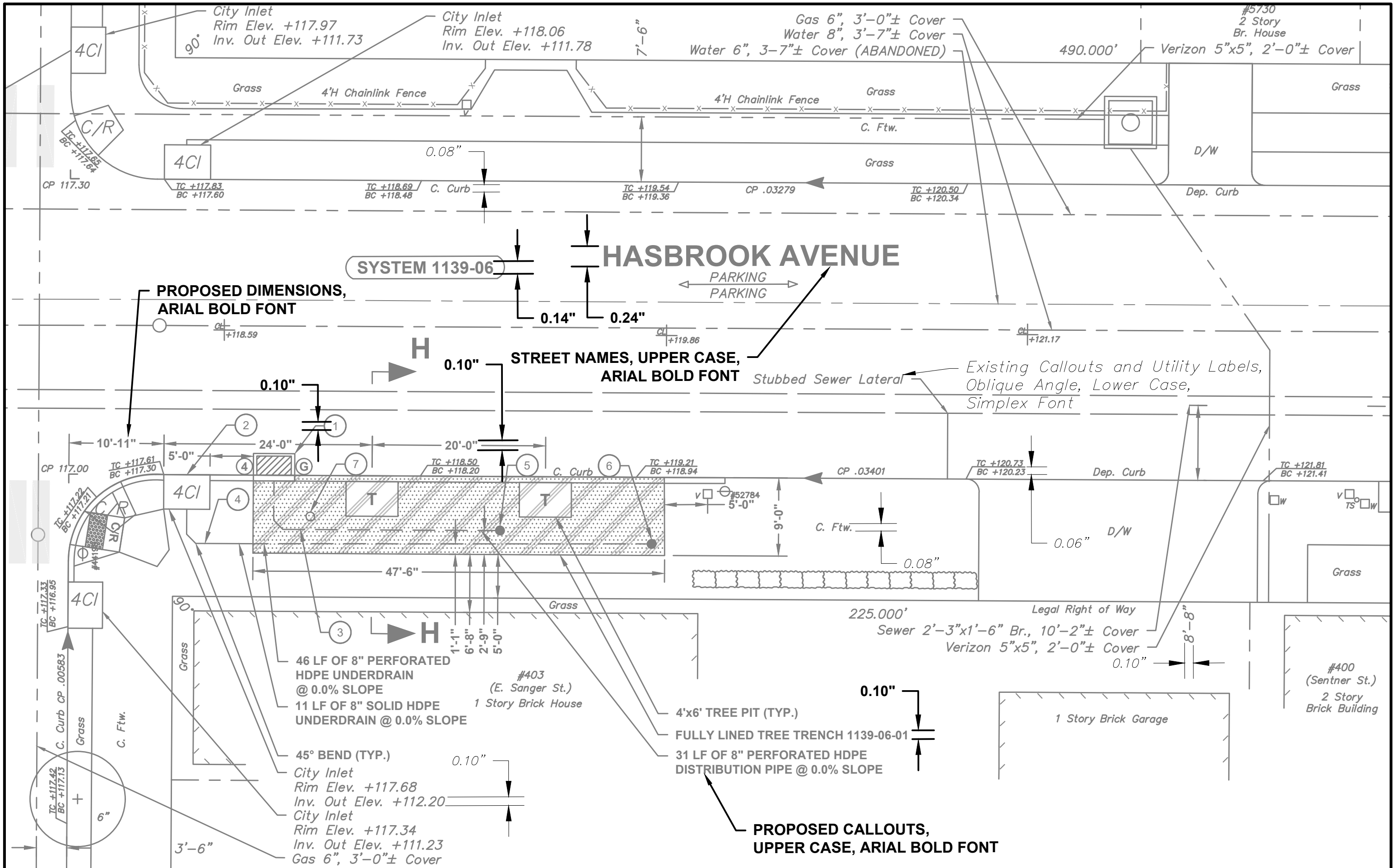

**PROPOSED DIMENSIONS,  
ARIAL BOLD FONT**

**STREET NAMES, UPPER CASE,  
ARIAL BOLD FONT**

*Existing Callouts and Utility Labels,  
Oblique Angle, Lower Case,  
Simplex Font*

**PROPOSED CALLOUTS,  
UPPER CASE, ARIAL BOLD FONT**

City Inlet  
Rim Elev. +117.97  
Inv. Out Elev. +111.73

City Inlet  
Rim Elev. +118.06  
Inv. Out Elev. +111.78

Gas 6", 3'-0"± Cover  
Water 8", 3'-7"± Cover  
Water 6", 3'-7"± Cover (ABANDONED)

#5730  
2 Story  
Br. House  
Verizon 5"x5", 2'-0"± Cover

4CI  
TC +117.83  
BC +117.60

TC +118.69  
BC +118.48

TC +119.54  
BC +119.36

TC +120.50  
BC +120.34

Dep. Curb

**HASBROOK AVENUE**

SYSTEM 1139-06

PARKING  
PARKING

0.10"

0.10"

0.14" 0.24"

TC +120.73  
BC +120.23

TC +121.81  
BC +121.41

CP 117.00

TC +117.61  
BC +117.30

TC +118.50  
BC +118.20

TC +119.21  
BC +118.94

CP .03401

0.06"

0.08"

TC +117.33  
BC +116.95

Grass

46 LF OF 8" PERFORATED  
HDPE UNDERDRAIN  
@ 0.0% SLOPE  
11 LF OF 8" SOLID HDPE  
UNDERDRAIN @ 0.0% SLOPE

#403  
(E. Sanger St.)  
1 Story Brick House

4'x6' TREE PIT (TYP.)  
FULLY LINED TREE TRENCH 1139-06-01  
31 LF OF 8" PERFORATED HDPE  
DISTRIBUTION PIPE @ 0.0% SLOPE

225.000'  
Sewer 2'-3"x1'-6" Br., 10'-2"± Cover  
Verizon 5"x5", 2'-0"± Cover

1 Story Brick Garage

#400  
(Sentner St.)  
2 Story  
Brick Building

45° BEND (TYP.)  
City Inlet  
Rim Elev. +117.68  
Inv. Out Elev. +112.20  
City Inlet  
Rim Elev. +117.34  
Inv. Out Elev. +111.23  
Gas 6", 3'-0"± Cover

3'-6"

| BASE PLAN TEXT STYLES - NON-ANNOTATIVE |                |                   |   |                                      |
|--|----------------|-------------------|---|--------------------------------------|
| NAME                                   | FONT           | TEXT HEIGHT       | EFFECTS                                 | USE                                  |
| EX-40                                  | simplex.shx    | 0.40              | Width Factor: 1.0<br>Oblique Angle: 15° | Section text                         |
| EX-100                                 | simplex.shx    | 1.00              | Width Factor: 1.0<br>Oblique Angle: 15° | Building number text                 |
| Simplex Ob                             | simplex.shx    | 0                 | Width Factor: 1.0<br>Oblique Angle: 15° | Text within block library blocks     |
| ARIAL                                  | Arial          | 0                 | Width Factor: 1.0<br>Oblique Angle: 0°  | Text within block library blocks     |
| ARIAL BOLD                             | Arial (Bold)   | 0                 | Width Factor: 1.0<br>Oblique Angle: 0°  | Text within block library blocks     |
| LINETYPES                              | Arial          | 0                 | Width Factor: 1.0<br>Oblique Angle: 0°  | Linetype text                        |
| LINETYPES I                            | Arial (Italic) | 0                 | Width Factor: 1.0<br>Oblique Angle: 0°  | Linetype text                        |
| LEGEND                                 | Calibri        | 0                 | Width Factor: 1.0<br>Oblique Angle: 0°  | Legend text                          |
| BASE PLAN TEXT STYLES - ANNOTATIVE     |                |                   |   |                                      |
| NAME                                   | FONT           | PAPER TEXT HEIGHT | EFFECTS                                 | USE                                  |
| EX-100a                                | simplex.shx    | 0.10              | Width Factor: 1.0<br>Oblique Angle: 15° | Building number text                 |
| EX-60                                  | simplex.shx    | 0.06              | Width Factor: 1.0<br>Oblique Angle: 15° | Utility feature text (IE: vent box)  |
| EX-80                                  | simplex.shx    | 0.08              | Width Factor: 1.0<br>Oblique Angle: 15° | Surface/Land use text (IE: Open Lot) |

| BASE PLAN MULTILEADER STYLES |                |              |                  |            |                  |                           |                    |
|------------------------------|----------------|--------------|------------------|------------|------------------|---------------------------|--------------------|
| NAME                         | ARROWHEAD SIZE | LEADER BREAK | LANDING DISTANCE | ANNOTATIVE | MULTILEADER TYPE | SOURCE BLOCK / TEXT STYLE | ATTACHMENT         |
| EX-TXT-MISC LBL              | 0.10           | 0.1250       | 0.10             | YES        | Mtext            | EX-100a                   | Middle of top line |
| EX-TXT-SECT LBL              | 0.40           | 0.1250       | 0.50             | NO         | Mtext            | EX-40                     | Middle of top line |
| EX-TXT-ST FTR LBL            | 0.08           | 0.1250       | 0.08             | YES        | Mtext            | EX-80                     | Middle of top line |
| EX-TXT-UTL LBL               | 0.10           | 0.1250       | 0.10             | YES        | Mtext            | EX-100a                   | Middle of top line |
| EX-TC BC SPOT ELEV           | 0.00           | 0.1250       | 0.06             | YES        | Mtext            | EX-60                     | Underline top line |
| EX-TC BC SPOT ELEV           | 0.01           | 0.1250       | 0.06             | YES        | Mtext            | EX-60                     | Middle of top line |

| BASE PLAN DIMENSION STYLES |            |            |         |                    |           |              |                     |                 |                  |                          |
|----------------------------|------------|------------|---------|--------------------|-----------|--------------|---------------------|-----------------|------------------|--------------------------|
| NAME                       | ANNOTATIVE | ARROW SIZE | TEXT    | LINEAR UNIT FORMAT | PRECISION | SCALE FACTOR | ANGULAR UNIT FORMAT | DECIMAL DEGREES | ZERO SUPPRESSION | USE                      |
| EX-DIMS-SECT               | NO         | 0.56       | EX-40   | Architectural      | 0'-0"     | 12           | Decimal Degrees     | 0               | 0 feet, 0 inches | Section dimension        |
| EX-DIMS-UTIL               | YES        | 0.14       | EX-100a | Architectural      | 0'-0"     | 12           | Decimal Degrees     | 0               | 1 feet, 0 inches | Utility offset dimension |

| <b>DESIGN PLAN TEXT STYLES - NON-ANNOTATIVE</b> |                |                          |   |  |
|---|----------------|--------------------------|---|--|
| <b>NAME</b>                                     | <b>FONT</b>    | <b>TEXT HEIGHT</b>       | <b>EFFECTS</b>                            | <b>USE</b>   |
| EX-40   | simplex.shx    | 0.40                     | Width Factor: 1.0<br>Oblique Angle: 15°   | Existing section text  |
| EX-50-HORIZ                                     | simplex.shx    | 0.5                      | Width Factor: 2.0<br>Oblique Angle: 15°   | Horizontal text for dimensions in elevation view at 1" = 10' scale |
| EX-50-HORIZ-20                                  | simplex.shx    | 0.5                      | Width Factor: 4.0<br>Oblique Angle: 15°   | Horizontal text for dimensions in elevation view at 1" = 20' scale |
| EX-50-HORIZ-30                                  | simplex.shx    | 0.5                      | Width Factor: 6.0<br>Oblique Angle: 15°   | Horizontal text for dimensions in elevation view at 1" = 30' scale |
| EX-50-VERT                                      | simplex.shx    | 1.0                      | Width Factor: 0.5<br>Oblique Angle: 15°   | Vertical text for dimensions in elevation view at 1" = 10' scale   |
| EX-50-VERT-20                                   | simplex.shx    | 2.0                      | Width Factor: 0.25<br>Oblique Angle: 15°  | Vertical text for dimensions in elevation view at 1" = 20' scale   |
| EX-50-VERT-30                                   | simplex.shx    | 3.0                      | Width Factor: 0.167<br>Oblique Angle: 15° | Vertical text for dimensions in elevation view at 1" = 30' scale   |
| EX-100  | simplex.shx    | 1.00                     | Width Factor: 1.0<br>Oblique Angle: 15°   | Existing plan view text  |
| EX-120  | simplex.shx    | 1.20                     | Width Factor: 1.0<br>Oblique Angle: 15°   | Text for dimensions in section view at 1/12" = 1' scale            |
| G-40  | Arial (Bold)   | 0.40                     | Width Factor: 1.0<br>Oblique Angle: 0°    | Proposed section text  |
| G-50-HORIZ                                      | Arial (Bold)   | 0.5                      | Width Factor: 2.0<br>Oblique Angle: 0°    | Horizontal text for dimensions in elevation view at 1"=10' scale   |
| G-50-HORIZ-20                                   | Arial (Bold)   | 0.5                      | Width Factor: 4.0<br>Oblique Angle: 0°    | Horizontal text for dimensions in elevation view at 1"=20' scale   |
| G-50-HORIZ-30                                   | Arial (Bold)   | 0.5                      | Width Factor: 6.0<br>Oblique Angle: 0°    | Horizontal text for dimensions in elevation view at 1"=30' scale   |
| G-50-VERT                                       | Arial (Bold)   | .95                      | Width Factor: 0.55<br>Oblique Angle: 0°   | Vertical text for dimensions in elevation view at 1"=10' scale     |
| G-50-VERT-20                                    | Arial (Bold)   | 2.0                      | Width Factor: 0.25<br>Oblique Angle: 0°   | Vertical text for dimensions in elevation view at 1"=20' scale     |
| G-50-VERT-30                                    | Arial (Bold)   | 3.0                      | Width Factor: 0.167<br>Oblique Angle: 0°  | Vertical text for dimensions in elevation view at 1"=30' scale     |
| G-80  | Arial (Bold)   | 0.8                      | Width Factor: 1.0<br>Oblique Angle: 0°    | Text for dimensions in section view at 1/8" = 1' scale             |
| G-120   | Arial (Bold)   | 1.2                      | Width Factor: 1.0<br>Oblique Angle: 0°    | Text for dimensions in section view at 1/12" = 1' scale            |
| Simplex Ob                                      | simplex.shx    | 0                        | Width Factor: 1.0<br>Oblique Angle: 15°   | Text within block library blocks                                   |
| ARIAL   | Arial          | 0                        | Width Factor: 1.0<br>Oblique Angle: 0°    | Text within block library blocks                                   |
| ARIAL BOLD                                      | Arial (Bold)   | 0                        | Width Factor: 1.0<br>Oblique Angle: 0°    | Text within block library blocks                                   |
| LINETYPES                                       | Arial          | 0                        | Width Factor: 1.0<br>Oblique Angle: 0°    | Linetype text  |
| LINETYPES I                                     | Arial (Italic) | 0                        | Width Factor: 1.0<br>Oblique Angle: 0°    | Linetype text  |
| <b>DESIGN PLAN TEXT STYLES - ANNOTATIVE</b>     |                |                          |   |  |
| <b>NAME</b>                                     | <b>FONT</b>    | <b>PAPER TEXT HEIGHT</b> | <b>EFFECTS</b>                            | <b>USE</b>   |
| EX-100a   | simplex.shx    | 0.10                     | Width Factor: 1.0<br>Oblique Angle: 15°   | Existing plan view text  |
| G-100   | Arial (Bold)   | 0.10                     | Width Factor: 1.0<br>Oblique Angle: 0°    | Proposed plan view text  |
| G-100   | Arial (Bold)   | 0.10                     | Width Factor: 1.0<br>Oblique Angle: 0°    | Proposed landscape plan view text                                  |

Note: The 1" = 20', and 1" = 30' scales are intended for use with profiles that correlate to GSI Sewer Design Plans. The 1/8" = 1', and 1/12" = 1' scales are intended for cross sections that correlate to GSI Sewer Plans.



| DESIGN PLAN MULTILEADER STYLES |                |              |                  |            |            |                    |             |                                     |
|--------------------------------|----------------|--------------|------------------|------------|------------|--------------------|-------------|-------------------------------------|
| NAME                           | ARROWHEAD SIZE | LEADER BREAK | LANDING DISTANCE | ANNOTATIVE | TEXT STYLE | ATTACHMENT         | LANDING GAP | USE                                 |
| EXIST-PROF-TEXT                | 1.0            | 0.1250       | 2.0              | NO         | EX-50      | Middle of top line | 0.50        | Existing callout for elevation view |
| EXIST-SECT-TEXT                | 0.56           | 0.1250       | 0.5              | NO         | EX-40      | Middle of top line | 0.25        | Existing callout for section view   |
| EXIST-TEXT                     | 0.10           | 0.1250       | 0.1              | YES        | EX-100a    | Middle of top line | 0.10        | Existing callout for plan view      |
| PROP-PROF-TEXT                 | 1.0            | 0.1250       | 2.0              | NO         | G-50-HORIZ | Middle of top line | 0.50        | Proposed callout for elevation view |
| PROP-SECT-TEXT                 | 0.5            | 0.1250       | 0.5              | NO         | G-40       | Middle of top line | 0.25        | Proposed callout for section view   |
| PROP-TEXT                      | 0.10           | 0.1250       | 0.1              | YES        | G-100      | Middle of top line | 0.10        | Proposed callout for plan view      |

Note: The 1" = 20', and 1" = 30' scales are intended for use with profiles that correlate to GSI Sewer Design Plans. The 1/8" = 1', and 1/12" = 1' scales are intended for cross sections that correlate to GSI Sewer Plans.

| DESIGN DIMENSION STYLES |            |            |                                    |                |                    |           |              |                     |                 |                  |   |
|-------------------------|------------|------------|------------------------------------|----------------|--------------------|-----------|--------------|---------------------|-----------------|------------------|---|
| NAME                    | ANNOTATIVE | ARROW SIZE | ARROWHEAD - USER ARROW             | TEXT           | LINEAR UNIT FORMAT | PRECISION | SCALE FACTOR | ANGULAR UNIT FORMAT | DECIMAL DEGREES | ZERO SUPPRESSION | USE   |
| EX-PROF-DIMS-HORIZ      | NO         | 1.00       | _PROFILE ARROW-EX 10 SCALE HORIZ   | EX-50-HORIZ    | Architectural      | 0'-0"     | 12           | Decimal Degrees     | 0               | 1 feet, 0 inches | Existing feature profile view dimension at 1"=10' scale   |
| EX-PROF-DIMS-HORIZ-20   | NO         | 1.00       | _PROFILE ARROW-EX 20 SCALE HORIZ   | EX-50-HORIZ-20 | Architectural      | 0'-0"     | 12           | Decimal Degrees     | 0               | 1 feet, 0 inches | Existing feature profile view dimension at 1"=20' scale   |
| EX-PROF-DIMS-HORIZ-30   | NO         | 1.00       | _PROFILE ARROW-EX 30 SCALE HORIZ   | EX-50-HORIZ-30 | Architectural      | 0'-0"     | 12           | Decimal Degrees     | 0               | 1 feet, 0 inches | Existing feature profile view dimension at 1"=30' scale   |
| EX-PROF-DIMS-VERT       | NO         | 1.00       | _PROFILE ARROW-EX 10 SCALE VERT    | EX-50-VERT     | Architectural      | 0'-0"     | 12           | Decimal Degrees     | 0               | 1 feet, 0 inches | Existing feature profile view dimension at 1"=10' scale   |
| EX-PROF-DIMS-VERT-20    | NO         | 1.00       | _PROFILE ARROW-EX 20 SCALE VERT    | EX-50-VERT-20  | Architectural      | 0'-0"     | 12           | Decimal Degrees     | 0               | 1 feet, 0 inches | Existing feature profile view dimension at 1"=20' scale   |
| EX-PROF-DIMS-VERT-30    | NO         | 1.00       | _PROFILE ARROW-EX 30 SCALE VERT    | EX-50-VERT-30  | Architectural      | 0'-0"     | 12           | Decimal Degrees     | 0               | 1 feet, 0 inches | Existing feature profile view dimension at 1"=30' scale   |
| PR-PROF-DIMS-HORIZ      | NO         | 1.00       | _PROFILE ARROW-PROP 10 SCALE HORIZ | G-50-HORIZ     | Architectural      | 0'-0"     | 12           | Decimal Degrees     | 0               | 1 feet, 0 inches | Proposed feature profile view dimension at 1"=10' scale   |
| PR-PROF-DIMS-HORIZ-20   | NO         | 1.00       | _PROFILE ARROW-PROP 20 SCALE HORIZ | G-50-HORIZ-20  | Architectural      | 0'-0"     | 12           | Decimal Degrees     | 0               | 1 feet, 0 inches | Proposed feature profile view dimension at 1"=20' scale   |
| PR-PROF-DIMS-HORIZ-30   | NO         | 1.00       | _PROFILE ARROW-PROP 30 SCALE HORIZ | G-50-HORIZ-30  | Architectural      | 0'-0"     | 12           | Decimal Degrees     | 0               | 1 feet, 0 inches | Proposed feature profile view dimension at 1"=30' scale   |
| PR-PROF-DIMS-VERT       | NO         | 1.00       | _PROFILE ARROW-PROP 10 SCALE VERT  | G-50-VERT      | Architectural      | 0'-0"     | 12           | Decimal Degrees     | 0               | 1 feet, 0 inches | Proposed feature profile view dimension at 1"=10' scale   |
| PR-PROF-DIMS-VERT-20    | NO         | 1.00       | _PROFILE ARROW-PROP 10 SCALE VERT  | G-50-VERT-20   | Architectural      | 0'-0"     | 12           | Decimal Degrees     | 0               | 1 feet, 0 inches | Proposed feature profile view dimension at 1"=20' scale   |
| PR-PROF-DIMS-VERT-30    | NO         | 1.00       | _PROFILE ARROW-PROP 10 SCALE VERT  | G-50-VERT-30   | Architectural      | 0'-0"     | 12           | Decimal Degrees     | 0               | 1 feet, 0 inches | Proposed feature profile view dimension at 1"=30' scale   |
| PR-DIMS                 | YES        | 0.14       | N/A                                | G-100          | Architectural      | 0'-0"     | 12           | Decimal Degrees     | 0               | 1 feet, 0 inches | Proposed feature plan view dimension                      |
| EX-SECT-DIMS            | NO         | 0.56       | N/A                                | EX-40          | Architectural      | 0'-0"     | 12           | Decimal Degrees     | 0               | 1 feet, 0 inches | Existing feature section view dimension at 1/4"=1' scale  |
| EX-SECT-DIMS 1-8        | NO         | 1.12       | N/A                                | EX-80          | Architectural      | 0'-0"     | 12           | Decimal Degrees     | 0               | 1 feet, 0 inches | Existing feature section view dimension at 1/8"=1' scale  |
| EX-SECT-DIMS 1-12       | NO         | 1.68       | N/A                                | EX-120         | Architectural      | 0'-0"     | 12           | Decimal Degrees     | 0               | 1 feet, 0 inches | Existing feature section view dimension at 1/12"=1' scale |
| PR-SECT-DIMS            | NO         | 0.56       | N/A                                | G-40           | Architectural      | 0'-0"     | 12           | Decimal Degrees     | 0               | 1 feet, 0 inches | Proposed feature section view dimension at 1/4"=1' scale  |
| PR-SECT-DIMS 1-8        | NO         | 1.12       | N/A                                | G-80           | Architectural      | 0'-0"     | 12           | Decimal Degrees     | 0               | 1 feet, 0 inches | Proposed feature section view dimension at 1/8"=1' scale  |
| PR-SECT-DIMS 1-12       | NO         | 1.68       | N/A                                | G-120          | Architectural      | 0'-0"     | 12           | Decimal Degrees     | 0               | 1 feet, 0 inches | Proposed feature section view dimension at 1/12"=1' scale |

Note: The 1" = 20', and 1" = 30' scales are intended for use with profiles that correlate to GSI Sewer Design Plans. The 1/8" = 1', and 1/12" = 1' scales are intended for cross sections that correlate to GSI Sewer Plans.

## APPENDIX D: DYNAMIC BLOCK FUNCTIONS

## Dynamic Block Functions

### Visibility

---



The visibility grip allows the drafter to toggle between various visibility states defined within a block. This function essentially allows multiple blocks to be stored within one block by either hiding or showing particular geometry in a visibility state.

By clicking on the triangular visibility grip, the drafter may choose which visibility state is to show. For example, the highway grate inlet block illustrates the usefulness of visibility states by storing variations of the inlet within the same block.

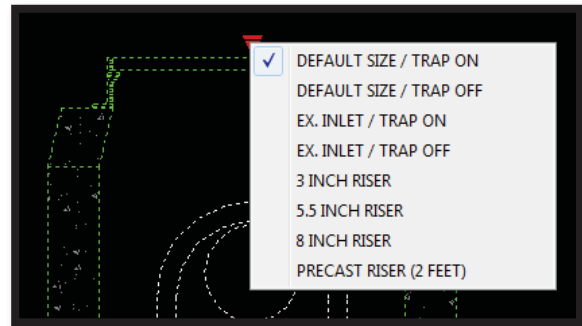

### Move Action

---



The dynamic block move action is associated with two types of grips, an arrowhead shape or a light blue square. Notice that the square grip is a slightly different color than the darker blue square block insert grip. The move action will drag an assigned portion of the block geometry to the location of your choice. It is common for text within blocks

to be associated with a move action so that it may be relocated without moving the entire block. Move actions using the square grip allow for geometry to be moved in any direction while move actions using the arrowhead shape constrain the move to a defined axis or along a linear path between two points.

### Stretch Action

---

The stretch action uses the same two types of grips as the move action; however, more commonly the arrowhead shape is used. The stretch action will elongate or shorten the associated geometry within the block. This is useful for the cleanout shown below as the cleanout's geometry is dependent on the depth of the pipe it is connecting to.

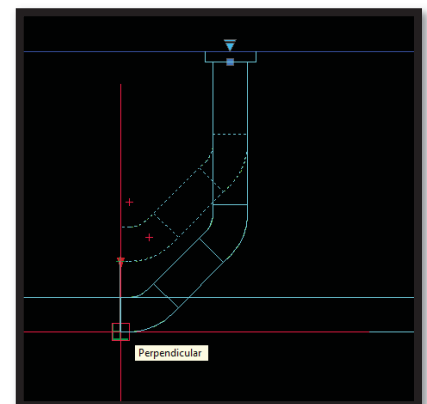

## Scale Action

---



The scale action uses the same two grip types as the move and stretch action. The scale action will enlarge or shrink the associated block geometry uniformly.

## Rotate Action

---

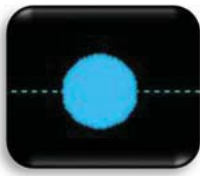

The rotate action uses a circle grip to rotate the associated geometry within the block. Some dynamic blocks are designed to rotate all geometry within the block while others may only have certain objects associated with the dynamic rotate function. If a dynamic block has a rotate action grip, it should be used instead of utilizing AutoCAD's rotate command.

## Flip Action

---



The flip action uses an arrow shaped grip to flip the associated geometry within the block along an axis perpendicular to the arrow alignment. A dynamic block may contain multiple flip actions each associated with different geometry within the block.

## Alignment Action

---



The alignment action grip will align the block parallel or perpendicular, depending on how the block is set-up, to another object. The grip may be used to move the block near the object to be used for alignment. The block will rotate accordingly when the grip moves over or snaps to the object. Please note, the direction in which the block is brought toward the reference object will determine along which side the block is aligned.

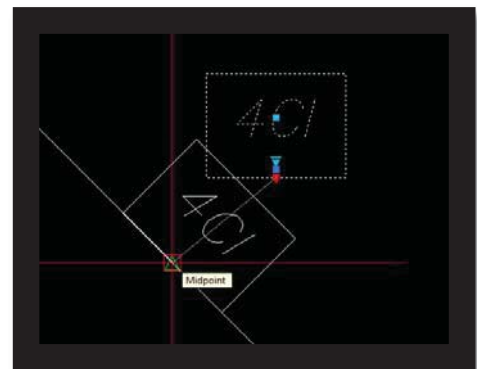

## Attribute Text

---

Attribute text is pre-defined within a block as a placeholder for the user to customize after the block is inserted into the drawing. Upon the insertion of the block, the user will be prompted to define what text value the attribute should display or the user may choose to insert the block with its default text value.

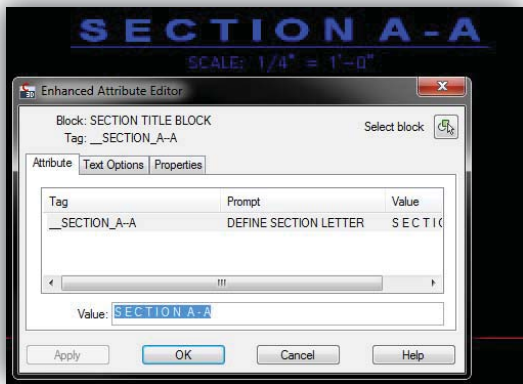

Attribute text may be edited at any time by double-clicking the block which will cause the “Enhanced Attribute Editor” window to display. Changing the value of the attribute will edit what text is displayed.

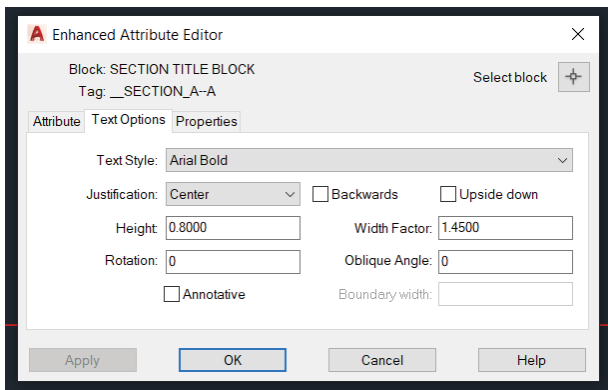

In the next tab, “Text Options”, the user may edit the format of the text displayed by the attribute. Attributes may be made annotative and the rotation may be changed to different values for different scales within the text options tab.

## Annotative Text within Blocks

---

Many common symbols may be made into blocks to save time in

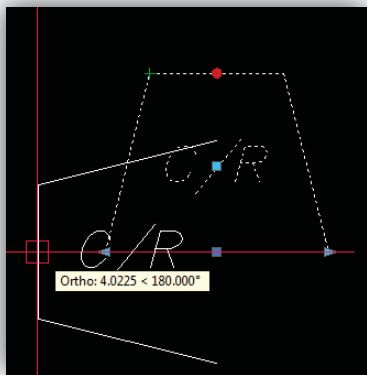

drafting. Some symbols are grouped with simple text of a constant value that should display upright in all plan views. Annotative text may be set to match orientation to layout so that it will scale and rotate automatically to display upright and at the correct size within a paper-space viewport that is set to a certain scale and user coordinate system (UCS).



Blocks containing annotative text set to match orientation to layout should not be rotated using AutoCAD's rotate command. This changes the direction the text recognizes as upright to the angle that the block has been rotated to. Blocks may be rotated using the dynamic rotate grip and the text will remain upright as the block geometry rotates.

Annotative text set to match orientation to layout will only automatically rotate when viewed through a paper-space viewport and will display in model space at the orientation in which it was inserted. It is recommended that all blocks with this type of text are inserted while in the defined "Plan" UCS. As opposed to the "World" UCS where the site is aligned by true coordinates, the "Plan" UCS shall best orient the site as it should be displayed on the location plan.

## **APPENDIX E: RECOMMENDED DRAFTING TIPS**

## EXTERNAL REFERENCING - TITLE BLOCK EXAMPLE

When externally referencing (xref) the title block, it is recommended to xref it into paper space within the prepared layout tab. If additional layout tabs are created, the referenced title block may be copied and pasted to additional layout tabs in a drawing.

1. Open the layout drawing into which the title block is to be inserted and navigate to the paperspace layout.
2. Open the xref manager (Command: "xref") and click to insert a .dwg reference.
3. Navigate to the copy of the "PWD GSI Title Block.dwg" file that you have saved in your project file location and named using the proper file naming convention for the project and select to open.
4. Accept the default settings as shown below:

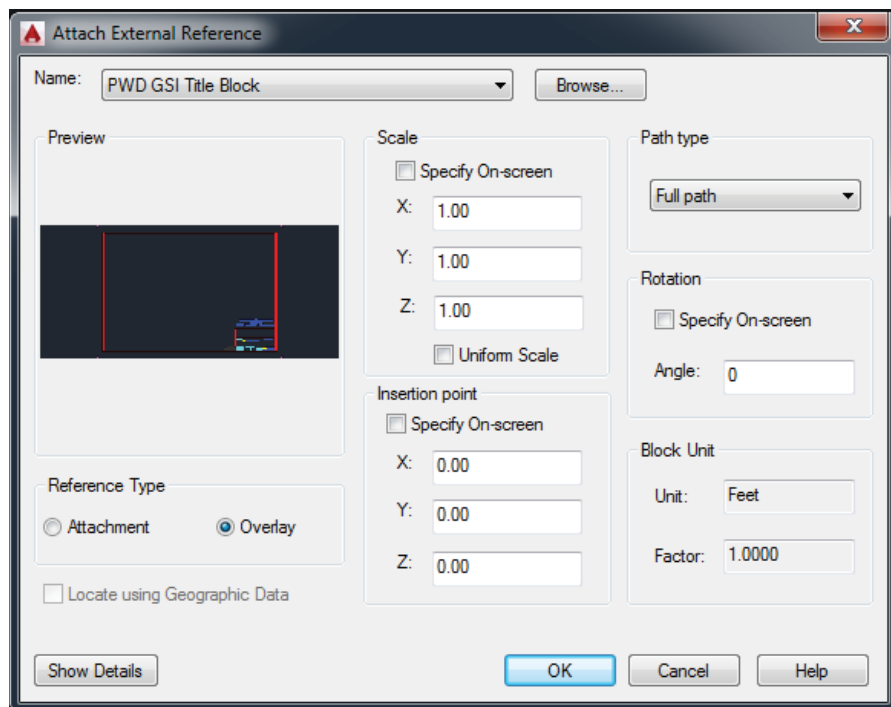

5. To insert the title block attributes that pair with the title block border, use the "Insert" command and select browse to navigate to the "PWD GSI Drawing Border Attributes 2021.dwg" file and select to open.

6. Please accept the default settings as shown below:

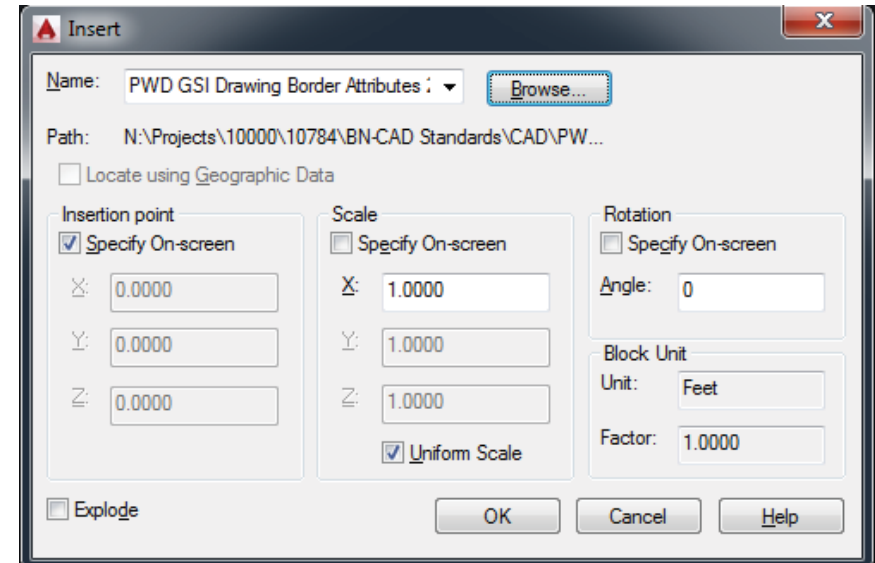

7. Upon block insertion you will be prompted to fill out the project information or accept the default values.

Please note that the above instructions to add an external reference also apply to other types of external reference files. To add references to model space, make model space active before adding the reference file and ensure that you are in the "World" User Coordinate System (UCS). It is recommended that references be inserted using the "Overlay" reference type.



# WORKING IN DESIGN CENTER

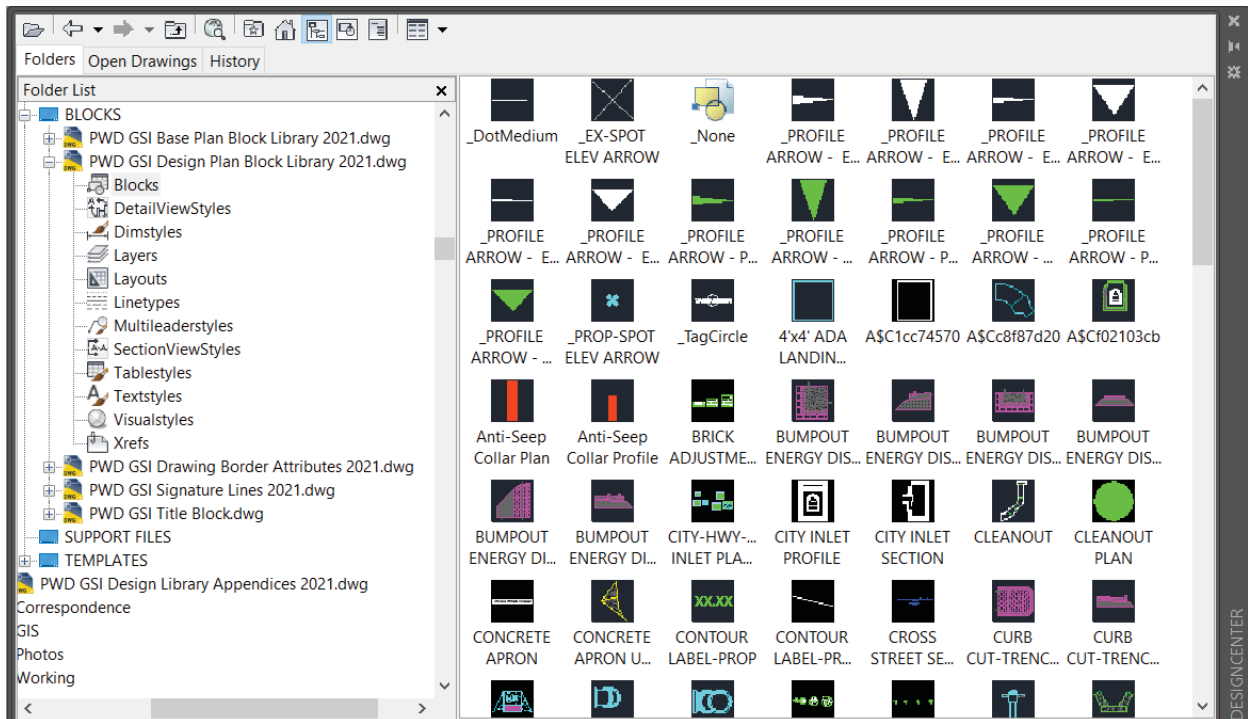

1. Open the Design Center by typing "DC" in the command line.
2. Under the "Folders" tab on the left, navigate to the block library\*.
3. Expand the library and select "Blocks".
4. Once the blocks load to the right, select the block you would like to insert and drag it from the design center dialogue into your drawing's model or paperspace.

\*Note: It is strongly recommended that the block libraries be saved locally to a user's hard drive rather than a network folder when utilizing Design Center. Saving to a network folder may cause lag and non-responsiveness. A default local drive location for files to be accessed through design center is "C:\Program Files\Autodesk\\Sample\en-us\DesignCenter" in a typical AutoCAD installation. Please note that you will need to replace <Select Year Version> with your version of AutoCAD.

## INSERTING BLOCKS CONTAINING MATCH-ORIENTATION-TO-LAYOUT TEXT

Many of the blocks containing text placed in plan view contain annotative text that will automatically rotate to display horizontally when viewed through a paperspace viewport. In this case it is the User Coordinate System (UCS) set to the viewport that determines the rotation automatically. In order for this to work properly, blocks of this type must be inserted in a certain manner.

To determine which blocks contain match-orientation-to-layout text, see Appendix A for the complete block library. Blocks marked with an asterisk (\*) contain this type of text.

1. Ensure that the UCS is set to "World". Find the area in which the blocks are to be inserted.

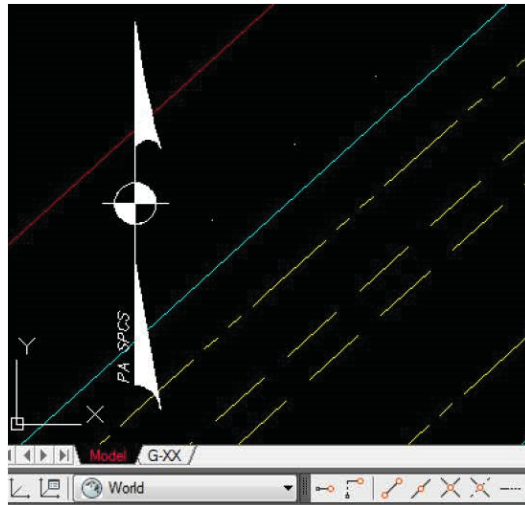

2. Insert the desired block using the "insert" command and place it at the desired location. If the block is not yet loaded in the drawing it will need to be brought in. See the "Working in Design Center" drafting tip in this Appendix for the recommended method.

3. While still in model space, switch to a UCS aligned as the plan will be shown on the layout. You will notice that the text will still be aligned such that it would display horizontally in the world UCS. This is correct for the text, however certain symbols will not be aligned as they should. Use the dynamic rotate grip provided to align symbols as desired.

NOTE: Only rotate with the dynamic grip, not the rotate command.

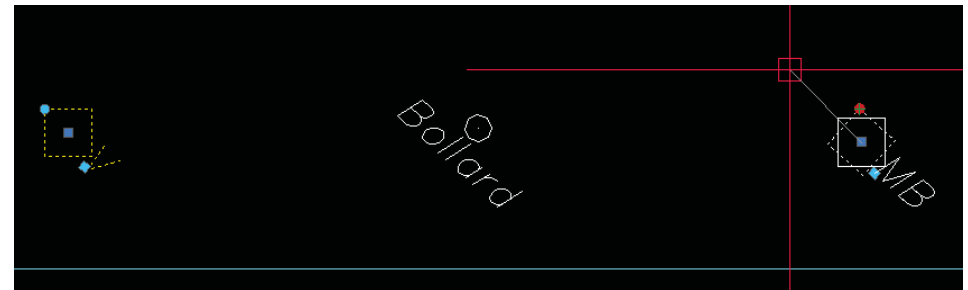

4. Switch to a layout and view the blocks through a viewport. The text should now view horizontally in any UCS. If the text is in conflict with any other item, move the text with the provided dynamic move grip.

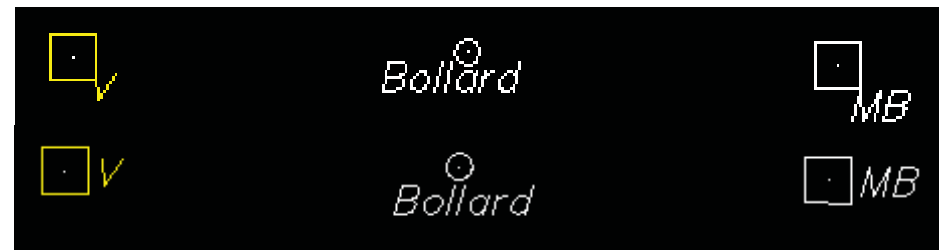

## CUSTOM INLET STYLE GUIDE

1. While in model space, import any of the inlet blocks. It is recommended that this be done through the Design Center. Refer to the "WORKING IN DESIGN CENTER" drafting tip in this Appendix.

2. For this example, the "OMG INLET PROFILE" and "OMG INLET SECTION" blocks are used.

3. For each block, select the "CUSTOM WITH TRAP" visibility state as shown below:

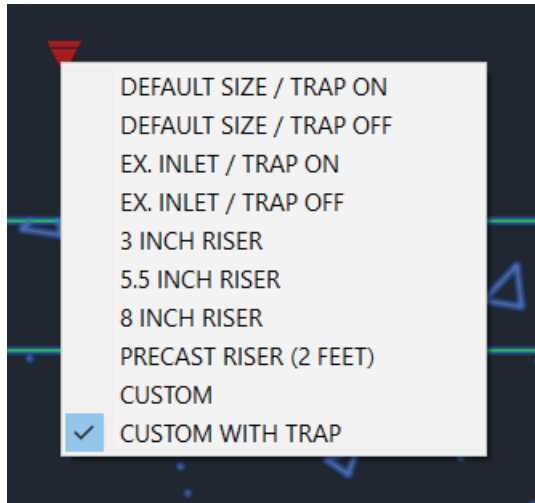

4. This will result in an inlet with a trap that can be adjusted by selecting the associated grip and moving the trap up or down. You also have the option to adjust the sump using the Stretch Action by selecting the grip and pulling it up or down. Note that wherever the trap is placed in section view, the profile view will need to be adjusted accordingly to match inverts, as this is not an automated feature.

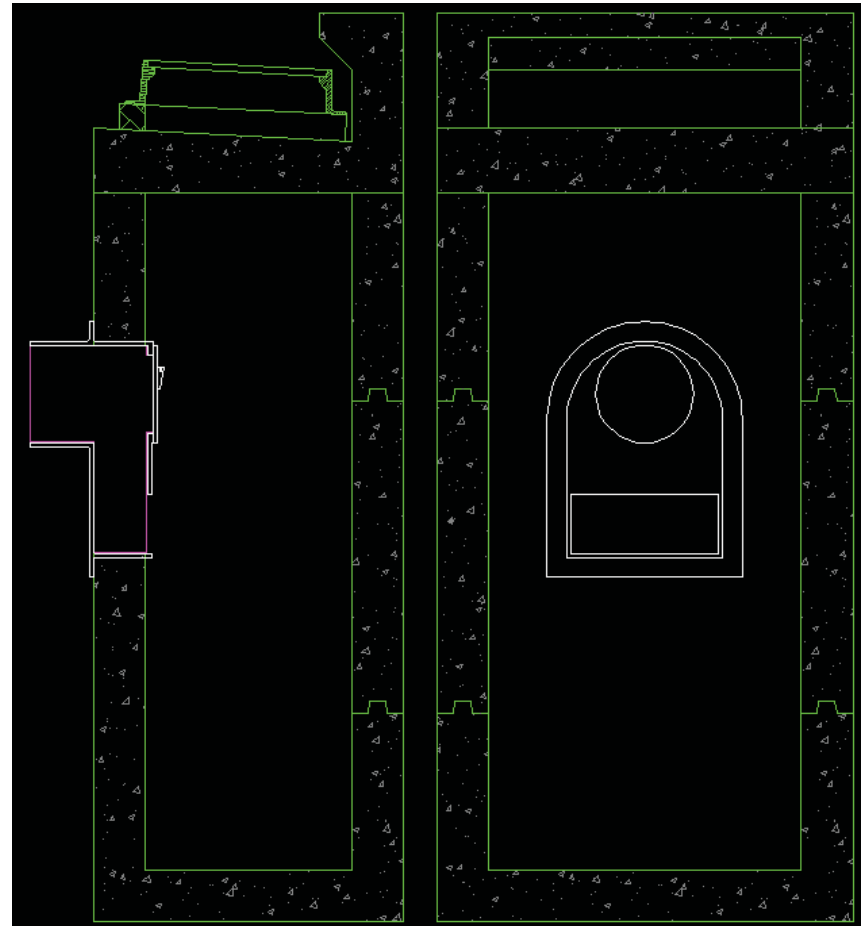

# ADDING SCALES TO ANNOTATIVE ATTRIBUTES

1. Blocks with annotative attribute text will insert to the correct size for the scale at which it is inserted. Any additional desired scales must be added as shown below. In this example, the "Tree Pit" block is used.

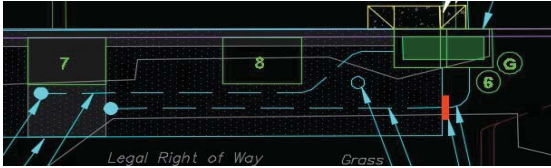

2. Isolate the blocks to which annotation scales will be added. The layer on which the block is inserted as well as the layer(s) used inside of the block must be turned on while all others are turned off or frozen. The layers within the block can be viewed using the "xlist" command.

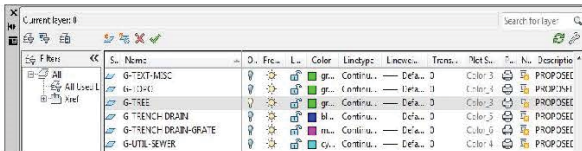

3. If the block is inserted at 10 scale, the text will size for that scale only. If switched to 20 scale, the text size will not change.

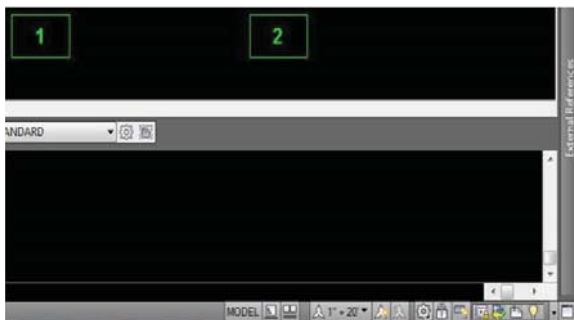

4. Switch back to the scale at which the block was inserted. Enable the function to automatically add scales to annotative objects when the annotation scale changes, as shown below.

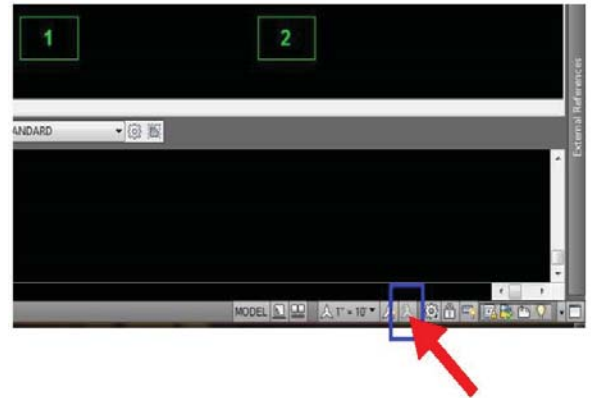

5. Switch to the scale which you wish to add to the block. The text should now size appropriately for that scale.

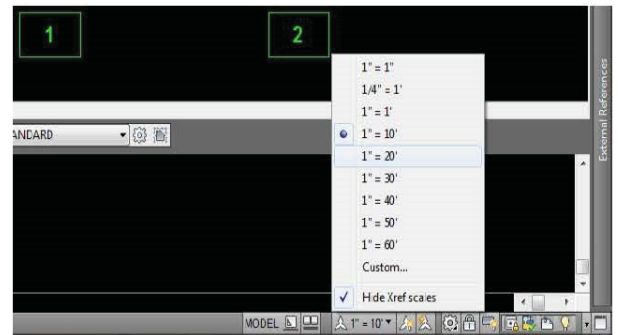

6. After the desired scales have been added, turn off the function to automatically add scales. The previously turned off or frozen layers may now be turned back on. Adjust text location for newly added scales.

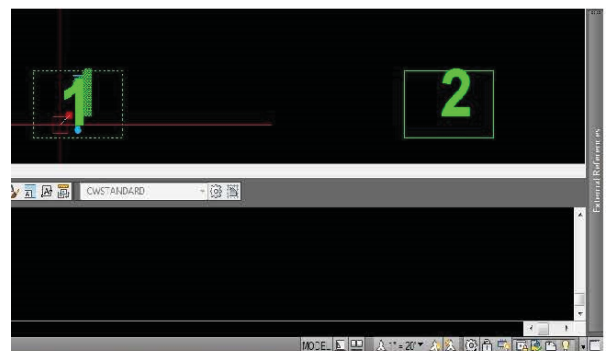

## CHANGING A MULTILEADER HEAD TO MEDIUM DOT

1. Select the multileader for which you would like to change the leader head. In most cases, a triangle arrowhead is used, however certain applications merit the use of a dot leader head. In cases where it is difficult to point to an outline, the dot leader is used to point to the internal area of the feature.

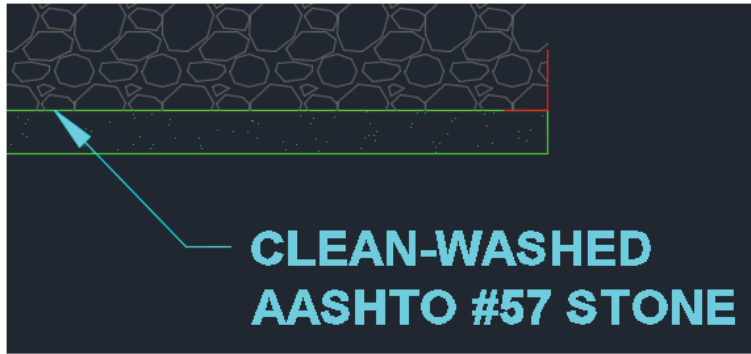

2. Open the properties dialog. Under the "Leaders" section find the line that says "Arrowhead." Click on the drop down menu and select "User Arrow".

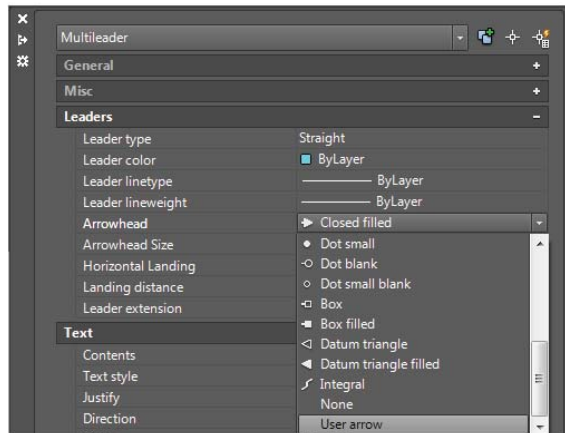

3. When the "Select Custom Arrow Block" window appears, choose "\_DotMedium" from the dropdown menu and click OK.

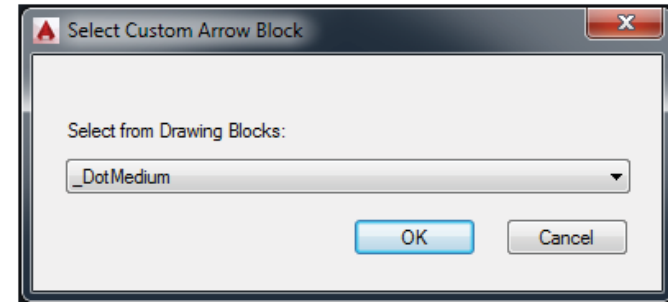

4. The leader head should now show a dot instead of the standard triangle arrowhead. Adjust the leader head to point to a location within the internal area of the object that is being called out.

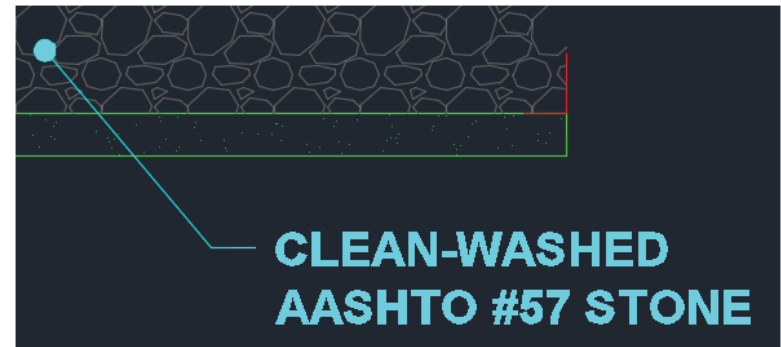

## Scaling a Profile at 1"=10' Horizontal Scale and 1"=5' Vertical Scale

1. In order to ease the drafting process and future revisions, it is recommended that profile/elevation views be drawn at a 1:1 ratio and then vertically stretched by a factor of two. First, select all objects for the profile excluding the title label.

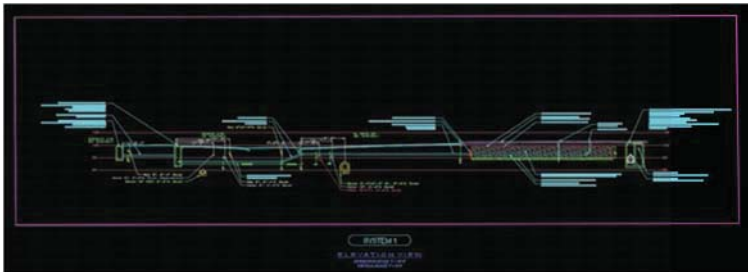

2. Activate the "block" command, and the block definition window will display. Ensure that the box to specify the base point on-screen is selected as well as allowing exploding. Ensure that the box to scale uniformly is not selected. It is recommended that you choose a base point that is consistent between multiple profiles. In this example, the top of the stone trench on the left is chosen.

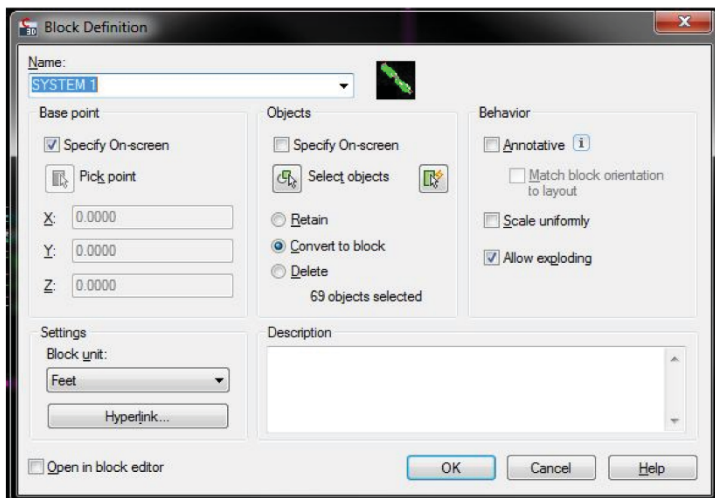

3. Select the newly-created profile block and open the properties menu. Under the "Geometry" section, change the Scale Y value to 2 to vertically stretch the block.

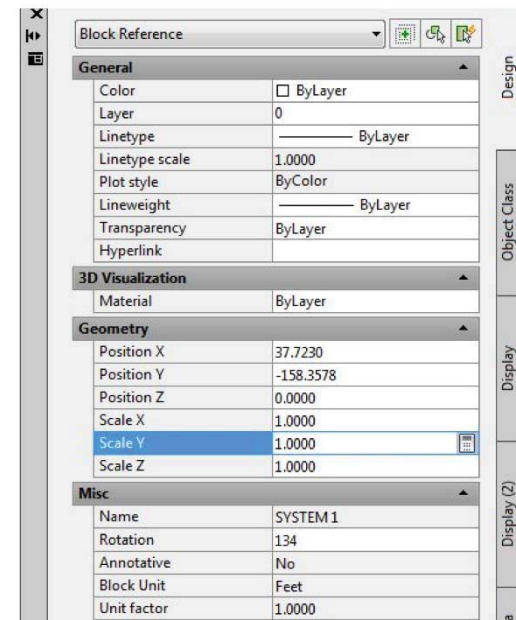

4. Now if displayed through a 10 scale viewport, the vertical scale of the profile will be at 5 scale.

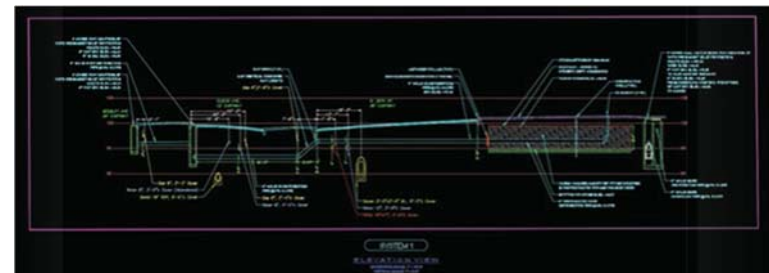

Note: Changes to the profile may be made in the block editor or the block may be exploded. Before exploding the block, be sure to change the "Scale Y" back to 1.

# GRAY SCALING FEATURES SEPARATED BY A MATCHLINE

MAKE SURE YOU CHANGE THE COLOR UNDER THE COLUMN "VP Color". "VP" STANDS FOR VIEWPORT.

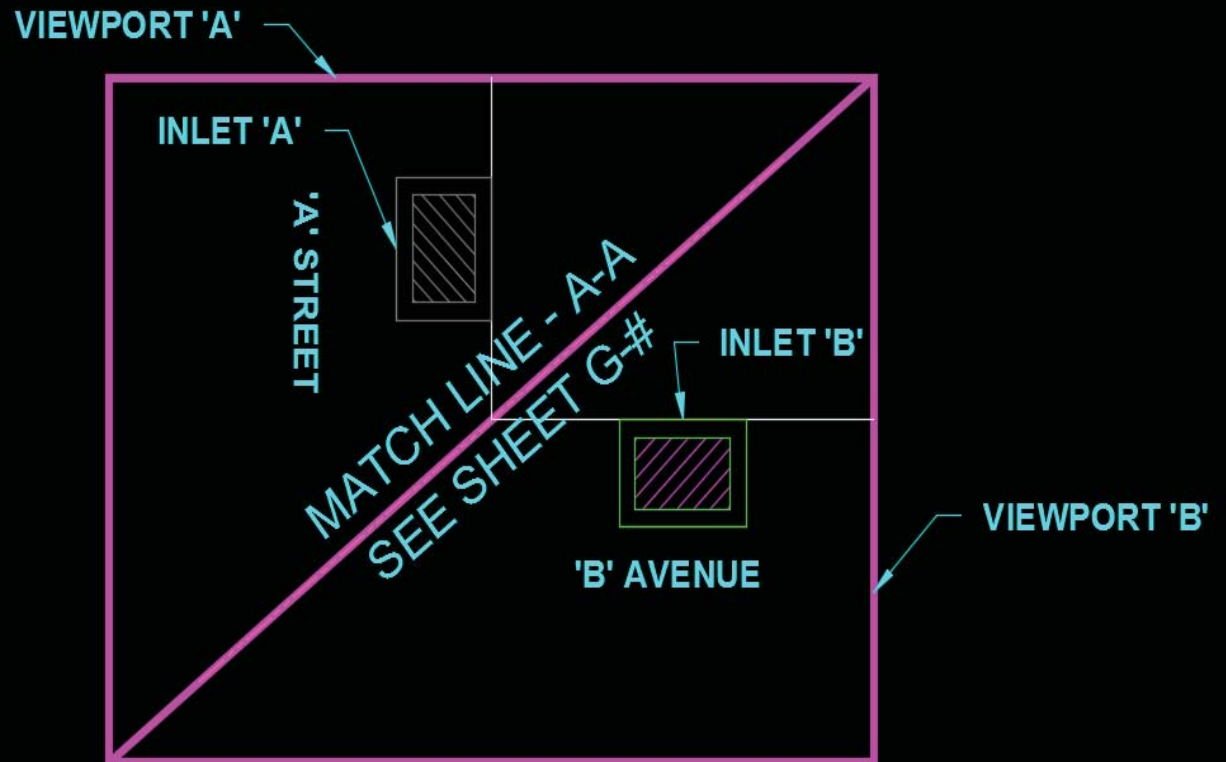
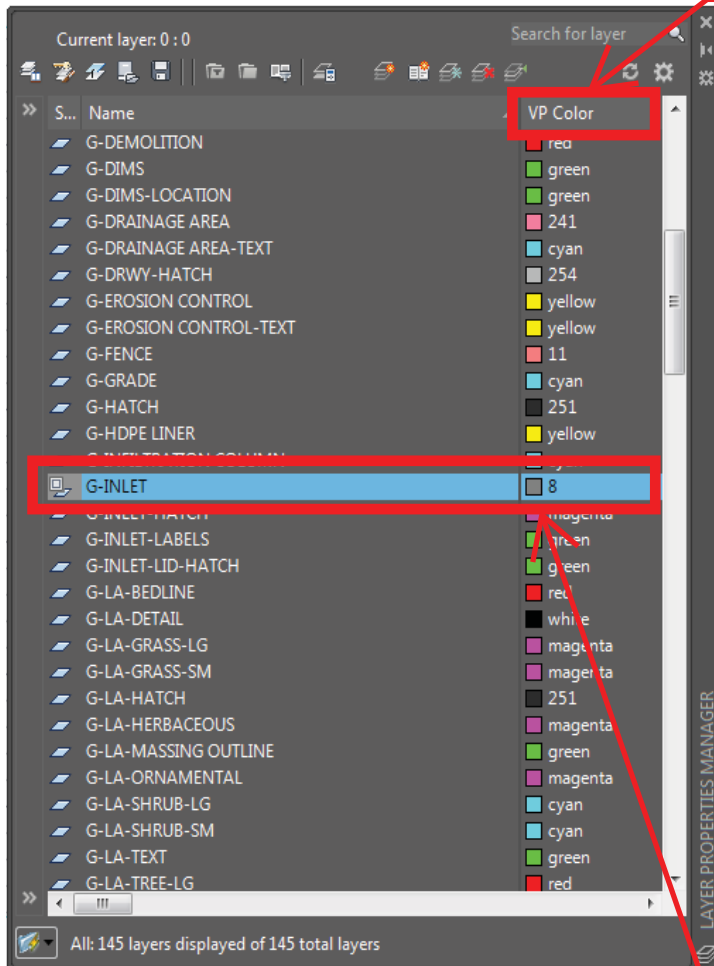

SELECT COLOR #8 TO GRAY OUT SELECTED LAYERS WHEN PRINTED

1. Copy an existing viewport over top of itself.
2. Clip the two viewports to share a common edge (the matchline).
3. Activate the viewport containing the layer(s) to be shown as gray.
4. Open the layer properties manager.
5. Select the layer(s) to be shown as gray.
6. Change the VP color to #8.

## PLOTTING

1. Please note that all three templates are preset to print using the provided plot style and default "DWG to PDF.pc3" PDF creator (An Autodesk default PDF publisher). Furthermore, paper size, plot scale, plot offset drawing orientation and other plot options have been pre-defined within the templates.
2. It is the user's responsibility to save the provided plot style to the appropriate location on their computer in order for it to map correctly within AutoCAD. See the "PWD GSI CAD Standards Support File Instructions for AutoCAD" document in the SUPPORT FILES folder for instructions on how to load the appropriate plot style into AutoCAD.
3. Accept the default values and press OK to create a full-size PDF. It is recommended to plot from the PDF rather than directly from AutoCAD to maintain consistency. Furthermore, printing half-size or 11x17 prints from the PDF maintains the lineweight scale. If you choose to plot directly to your own plotter, please be mindful of the plot area and select the appropriate size paper to print.

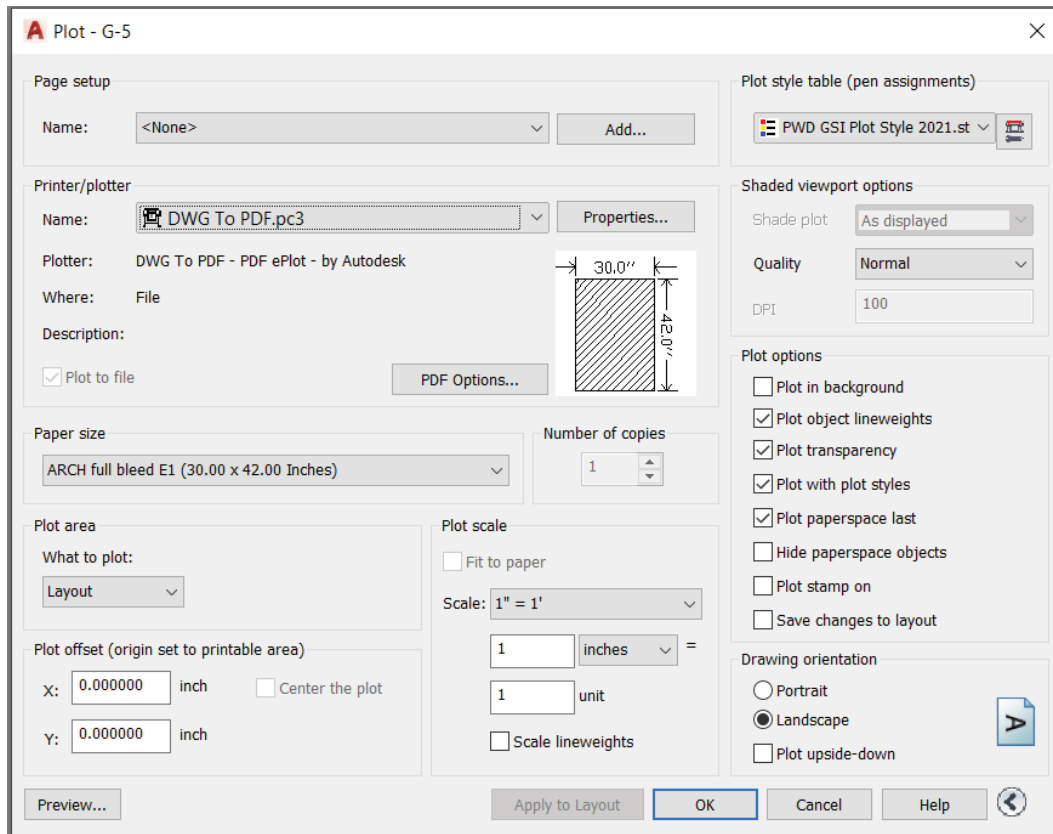

\*Note: Some PDF programs may experience errors with certain AutoCAD entities like wipeouts and some hatches. If you notice your drawings are not plotting as they should, for example inconsistently darkened and thickened linework or missing hatching sections, please plot directly to your printer/plotter. If a digital file like a PDF is desired, Review and printed to PDF from there. This will please utilize the "DWF6 ePlot.pc3" print driver. The .dwf file may be opened with Autodesk Design prevent printing errors that may occur with certain PDF software.



## "ETRANSMIT" TRANSMITTAL GUIDE

The "Etransmit" function in AutoCAD will automatically package files dependent on a layout drawing. Each layout drawing to be submitted to PWD will need to be "Etransmitted" separately.

1. Open the layout drawing and ensure that there are no unreferenced files. You may check by opening the file references window using the "XREF" command. Unreferenced files are listed as unreferenced in the file status column of the file references window.
2. Once satisfied with the state of the drawing, save the drawing and then use the "Etransmit" command. The "Create Transmittal" window will appear.

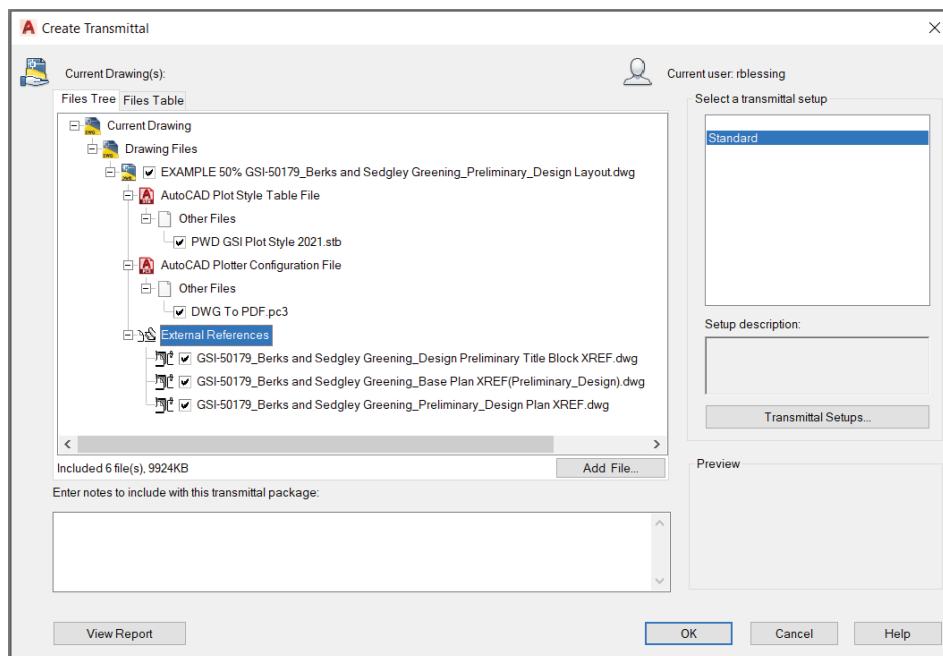

3. Review the files tree and ensure that all filenames follow the file naming convention.
4. Click the "OK" button to complete the "Etransmit". A window will appear to browse to the location where you would like the transmittal to be saved.
5. Once complete, the "Etransmit" will have saved a .zip file to the save location you selected. This .zip file along with any additional .zip files for each layout drawing transmittal should be sent to PWD.
6. The "Etransmit" .zip file will be extracted by the recipient. All external references will automatically map to the layout drawing.

**IMPORTANT:** Once the "Etransmit" .zip file is created, no files within should be renamed, moved, added, or deleted. This will interfere with the automatic remapping of external references when the .zip file is extracted.

## APPENDIX F: EXAMPLE PLANS

The following example plans have been provided:

### T-1 INDEX SHEET

- Title Sheet

### (30%) BASEPLAN

- Detailed Survey Sheet

### PRELIMINARY DESIGN (50%) UTILITY & GRADING PLAN

- Rain Garden
- Fully Lined Tree Trench

### SUBSTANTIALLY COMPLETE DESIGN (70%) UTILITY & GRADING PLAN

- Rain Garden
- Fully Lined Tree Trench
- Construction Details Sheet
- Large Area Disconnection

### PRE-FINAL (90%) DESIGN

- Partially Lined Tree Trench

### LANDSCAPE PLANS

- Rain Garden
- Tree Trench
- Landscape Details Sheet

### DRAINAGE AREA MAP

# CITY OF PHILADELPHIA

## PHILADELPHIA WATER DEPARTMENT

### DRAWINGS FOR: GREEN STORMWATER INFRASTRUCTURE PROJECT BERKS AND SEDGLEY GREENING PWD WORK NO. S-50179-G

| SHEET INDEX |   |
|-------------|---|
| SHEET NO.   | TITLE                                       |
| T-1         | GREEN STORMWATER INFRASTRUCTURE INDEX SHEET |
| G-1         | GRADING AND UTILITY PLAN - SYSTEM 1288-01   |
| G-2         | GRADING AND UTILITY PLAN - SYSTEM 1288-01   |
| G-3         | GRADING AND UTILITY PLAN - SYSTEM 1288-02   |
| G-4         | GRADING AND UTILITY PLAN - SYSTEM 1288-03   |
| G-5         | GRADING AND UTILITY PLAN - SYSTEM 1288-04   |
| G-6         | SITE PLAN - SYSTEM 1288-05                  |
| G-7         | GRADING AND UTILITY PLAN - SYSTEM 1288-05   |
| G-8         | GRADING AND UTILITY PLAN - SYSTEM 1288-05   |
| G-9         | GRADING AND UTILITY PLAN - SYSTEM 1288-05   |
| G-10        | GRADING AND UTILITY PLAN - SYSTEM 1288-06   |
| G-11        | GRADING AND UTILITY PLAN - SYSTEM 1288-07   |
| G-12        | GRADING AND UTILITY PLAN - SYSTEM 1288-09   |
| G-13        | GRADING AND UTILITY PLAN - SYSTEM 1288-10   |
| G-14        | GRADING AND UTILITY PLAN - SYSTEM 1288-11   |
| G-15        | GRADING AND UTILITY PLAN - SYSTEM 1288-12   |
| G-16        | CONSTRUCTION DETAILS 1                      |
| G-17        | CONSTRUCTION DETAILS 2                      |
| G-18        | CONSTRUCTION DETAILS 3                      |
| G-19        | CONSTRUCTION DETAILS 4                      |



MAP SOURCE: ESRI, DigitalGlobe, GeoEye, Earthstar Geographics, CNES/Airbus DS, USDA, USGS, AEX, Getmapping, Aerogrid, IGN, IGP, and the GIS User Community



| LEGEND   |                               |
|--|-------------------------------|
| Water Curb Box                                       | Unknown Utility Manhole       |
| Gas Curb Box   | Utility Manhole               |
| Water Box  | Grating                       |
| Unknown Curb Box                                     | Cellar Door                   |
| Pole   | Steps                         |
| Lamp Post  | Porch                         |
| PECO Pole  | Planter                       |
| PECO Pole w/ Light                                   | Bus Shelter                   |
| SEPTA Pole   | Curb Ramp                     |
| Traffic Light  | Compliant Curb Ramp           |
| Traffic Sign   | Tree/Trunk Size in "          |
| Iron Pole  | Tree Stump w/ Trunk in "      |
| Ballard  | Existing Pavement Markings    |
| Parking Meter  | Hedge                         |
| Parking Kiosk  | Trash Receptacle              |
| Standpipe  | Fence                         |
| Clean Out  | Right-of-Way Line             |
| Down Spout   | Bike Rack                     |
| Mail Box   | Existing Top/Bottom of Step   |
| Hand Hole  | Existing Top/Bottom of Curb   |
| Cable Hanghole                                       | Existing Spot Elevation       |
| Survey Stone   | C. Curb Concrete Curb         |
| Traffic Control Box (Above Ground)                   | G. Curb Granite Curb          |
| Verizon Junction Box (Above Ground)                  | Sl. Curb Slate Curb           |
| Bench Mark   | C. F.W. Concrete Footway      |
| Sewer Manhole  | Br. F.W. Brick Footway        |
| Water Valve  | A. F.W. Asphalt Footway       |
| Fire Hydrant   | Sl. F.W. Slate Footway        |
| Electrolysis Test Station                            | Dep. Curb Depressed Curb      |
| Highway Grate Inlet (4 Denotes 4 FT, 6 Denotes 6 FT) | Br. Gutter Brick Gutter       |
| Open Mouth (4 Denotes 4 FT, 6 Denotes 6 FT)          | D/W Driveway                  |
| Grate Inlet (4 Denotes 4 FT, 6 Denotes 6 FT)         | St. Wall Stone Wall           |
| City Inlet (4 Denotes 4 FT, 6 Denotes 6 FT)          | Br. Wall Brick Wall           |
| Old City Inlet (4 Denotes 4 FT, 6 Denotes 6 FT)      | C. Wall Concrete Wall         |
| Old Grate Inlet (4 Denotes 4 FT, 6 Denotes 6 FT)     | S.R.E. Sewer Return Elevation |
| Gas Valve (4 Denotes 4 FT, 6 Denotes 6 FT)           | S.R.L. Sewer Return Location  |
| Door Sill  |                               |

- GENERAL NOTES:
- ALL DISTANCES SHOWN ARE IN DISTRICT STANDARD MEASUREMENT. PAYMENT FOR ALL WORK WILL BE BASED UPON THAT STANDARD.
  - THE LOCATIONS AND ELEVATIONS OF THE EXISTING UTILITIES ARE APPROXIMATE. THE ELEVATIONS OF THE EXISTING UTILITIES MUST BE FIELD CHECKED DURING CONSTRUCTION.
  - ALL SIDEWALK AND CURBING TO BE REPLACED IN KIND ALONG FULL LIMITS OF CONSTRUCTION TO NEXT EXISTING JOINT OR AS DIRECTED BY PWD.
  - WELDED PIPE BOOT SEAL MUST BE INSTALLED AT ANY POINT WHERE A PIPE PENETRATES GEOMEMBRANE LINER.
  - SUFFICIENT EROSION AND SEDIMENTATION CONTROL MEASURES WILL BE INSTALLED AND MAINTAINED BY THE CONTRACTOR AS TO PREVENT STANDING WATER OR SEDIMENTATION OF STORMWATER SYSTEMS. SYSTEMS DETERMINED BY PWD TO BE INADEQUATELY PROTECTED AND THEREBY COMPROMISED WILL BE REPLACED TO THE EXTENT REQUIRED BY PWD (UP TO AND INCLUDING FULL REPLACEMENT) AT NO ADDITIONAL COST TO PWD.
  - ORIFICE SHOULD NOT BE DRILLED PRIOR TO AUTHORIZATION BY PWD. PWD WILL REVIEW THE RESULTS OF THE DOUBLE RING INFILTRATOR TESTS CONDUCTED AFTER SMP EXCAVATION AND WILL CONFIRM ORIFICE DIMENSIONS.
  - EROSION CONTROL MATTING SHALL BE PLACED OVER ALL SOIL SURFACES NOT STABILIZED BY PLANTING.
  - SUPPORT AND PROTECT ALL UTILITIES, UTILITY POLES, OVERHEAD WIRES, TRAFFIC SIGNAGE, TRAFFIC SIGNALS, AND STREET LIGHTING WITHIN THE LIMITS OF WORK.
  - VERTICAL DATUM IS ON CITY OF PHILADELPHIA DATUM
  - LINE AND GRADE STAKES FOR CURB, PAVING, ETC. WILL BE FURNISHED BY THE 9TH SURVEY DISTRICT OF THE CITY OF PHILADELPHIA. CONTACT INFORMATION: 9TH SURVEY DISTRICT, 4000 N. AMERICAN ST., PHILA., PA. 19140, (215) 685-3050
  - NOTIFY THE 9TH SURVEY DISTRICT A MINIMUM OF TWO (2) WEEKS PRIOR TO THE START OF WORK TO SCHEDULE A TIME FOR CURB STAKE LAYOUT SERVICES.

### GREEN STORMWATER INFRASTRUCTURE PROJECT

| INDEX SHEET                 |                                       |
|-----------------------------|---------------------------------------|
| BERKS AND SEDGLEY GREENING  |                                       |
| APPROVED _____              | CITY OF PHILADELPHIA WATER DEPARTMENT |
| APPROVED _____              | SCALE: 1" = 300'                      |
| APPROVED _____              |                                       |
| WORK NO. S-50179-G          |                                       |
| SHEET NO. T-1 OF 1 SHEETS   |                                       |
| DRAWN BY: CAD               | XXX XXXX                              |
| PROJECT ENGR: PROJECT ENGR. | XXX XXXX                              |
| SUPERVISOR                  | DATE                                  |

EXAMPLE PLAN 2021 - NOT FOR CONSTRUCTION  
THIS PLAN WAS DEVELOPED TO DEMONSTRATE DRAWING STANDARDS  
AND MAY NOT REFLECT CURRENT DESIGN STANDARDS

**DRAFT <MILESTONE>  
SUBMISSION <DATE>**



PHILADELPHIA WATER DEPARTMENT  
PLAN PREPARED FOR THE CITY OF PHILADELPHIA WATER DEPARTMENT BY:

INSERT COMPANY LOGO AND ADDRESS HERE

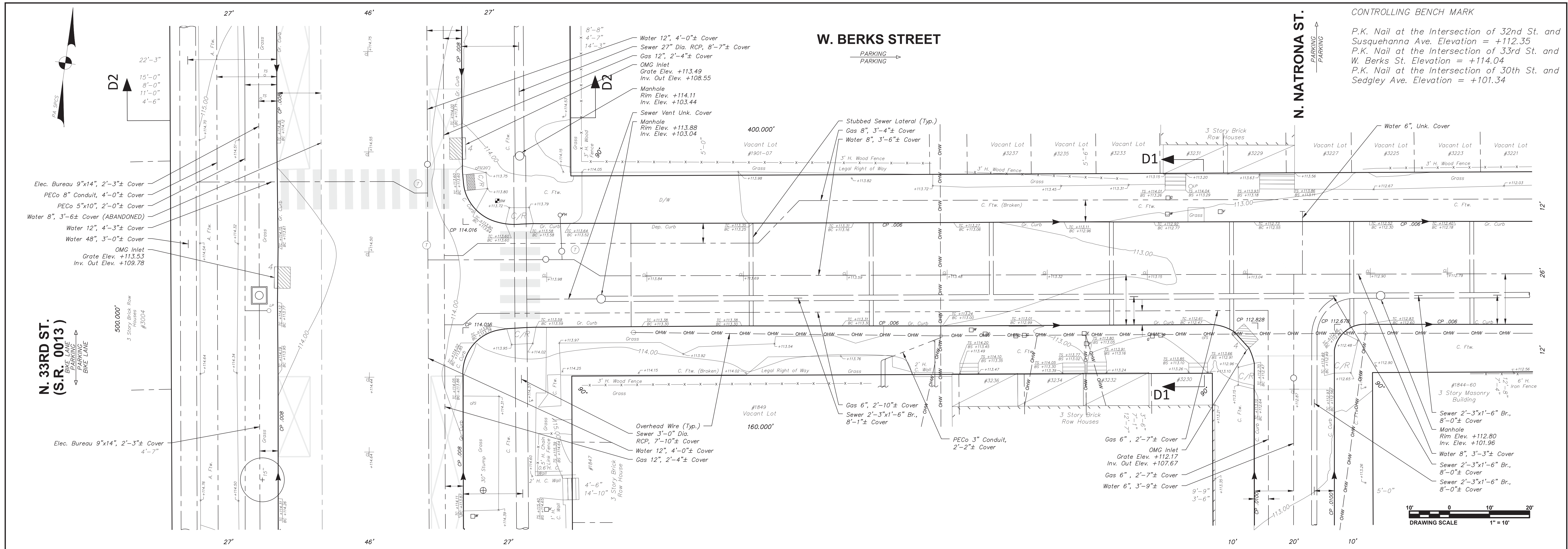

CONTROLLING BENCH MARK  
 P.K. Nail at the Intersection of 32nd St. and  
 Susquehanna Ave. Elevation = +112.35  
 P.K. Nail at the Intersection of 33rd St. and  
 W. Berks St. Elevation = +114.04  
 P.K. Nail at the Intersection of 30th St. and  
 Sedgley Ave. Elevation = +101.34

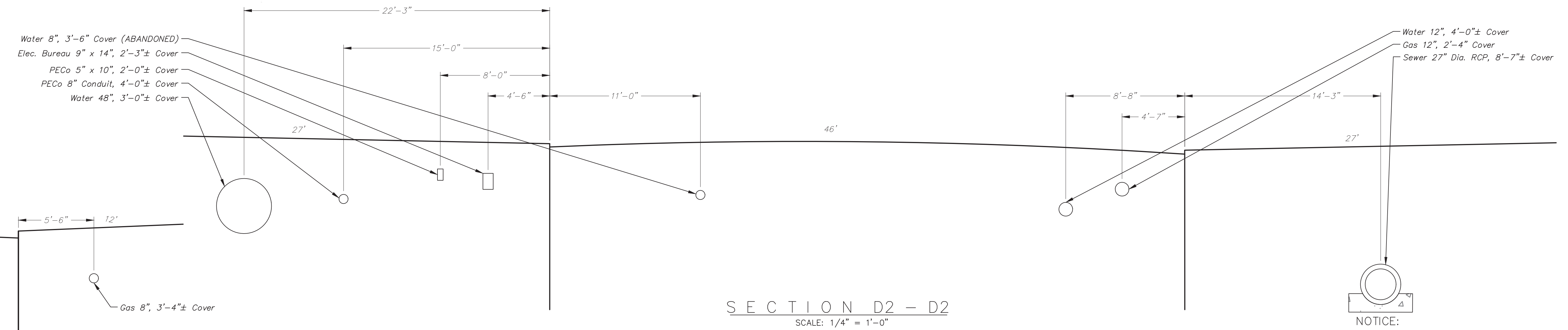
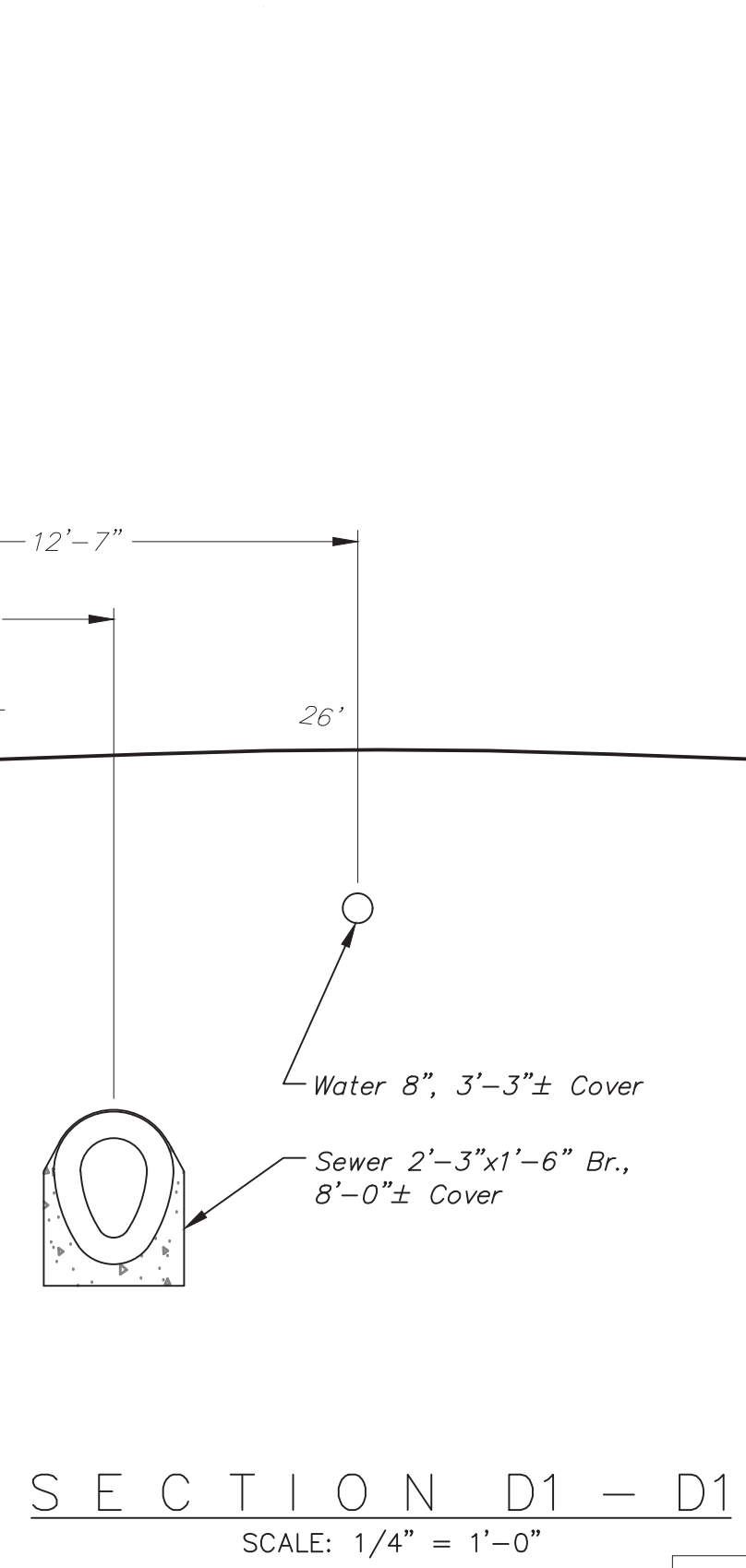

GENERAL NOTES:  
 1. ALL DISTANCES SHOWN ARE IN DISTRICT STANDARD MEASUREMENT. PAYMENT FOR ALL WORK WILL BE BASED UPON THAT STANDARD.  
 2. THE LOCATIONS AND ELEVATIONS OF THE EXISTING UTILITIES ARE APPROXIMATE. THE ELEVATIONS OF THE EXISTING UTILITIES MUST BE FIELD CHECKED DURING CONSTRUCTION.

| LEGEND             |   |
|--------------------|---|
| Water Curb Box     | Utility Manhole                                     |
| Gas Curb Box       | Grating   |
| Water Box          | Cellar Door   |
| Unknown Curb Box   | Steps   |
| Pole               | Porch   |
| Lamp Post          | Planter   |
| PECO Pole          | Bus Shelter   |
| PECO Pole w/ Light | Curb Ramp   |
| SEPTA Pole         | Compliant Curb Ramp                                 |
| Traffic Light      | Tree/Trunk Size in "                                |
| Traffic Sign       | Tree/Trunk Size in "                                |
| Iron Pole          | Existing Pavement Markings                          |
| Bollard            | Hedge   |
| Parking Meter      | Trash Receptacle                                    |
| Parking Kiosk      | Fence   |
| Standpipe          | Right-of-Way Line                                   |
| Clean Out          | Bike Rack   |
| Down Spout         |   |
| Mail Box           |   |
| Hand Hole          |   |
|                    | Cable Handhole                                      |
|                    | Survey Stone  |
|                    | Traffic Control Box                                 |
|                    | (Above Ground)                                      |
|                    | Verizon Junction Box                                |
|                    | (Above Ground)                                      |
|                    | Bench Mark  |
|                    | Sewer Manhole                                       |
|                    | Water Valve   |
|                    | Fire Hydrant  |
|                    | Electrolysis Test Station                           |
|                    | Highway Gate Inlet (4 Denotes 4 FT, 6 Denotes 6 FT) |
|                    | Open Mouth (4 Denotes 4 FT, 6 Denotes 6 FT)         |
|                    | Gate Inlet (4 Denotes 4 FT, 6 Denotes 6 FT)         |
|                    | City Inlet (4 Denotes 4 FT, 6 Denotes 6 FT)         |
|                    | Old City Inlet (4 Denotes 4 FT, 6 Denotes 6 FT)     |
|                    | Old Gate Inlet (4 Denotes 4 FT, 6 Denotes 6 FT)     |
|                    | Gas Valve   |
|                    | Door Sign   |
|                    | Unknown Utility Manhole                             |
|                    | Existing Top/Bottom of Step                         |
|                    | Existing Top/Bottom of Curb                         |
|                    | Existing Spot Elevation                             |
|                    | C. Curb Concrete Curb                               |
|                    | G. Curb Granite Curb                                |
|                    | S. Curb Slate Curb                                  |
|                    | C. F.W. Concrete Footway                            |
|                    | Br. F.W. Brick Footway                              |
|                    | A. F.W. Asphalt Footway                             |
|                    | S. F.W. Slate Footway                               |
|                    | Dep. Curb Depressed Curb                            |
|                    | Br. Gutter Brick Gutter                             |
|                    | D/W Driveway  |
|                    | St. Wall Stone Wall                                 |
|                    | Br. Wall Brick Wall                                 |
|                    | C. Wall Concrete Wall                               |
|                    | S.R.E. Sewer Return Elevation                       |
|                    | S.R.L. Sewer Return Location                        |

EXAMPLE PLAN 2021 - NOT FOR CONSTRUCTION  
 THIS PLAN WAS DEVELOPED TO DEMONSTRATE DRAWING STANDARDS  
 AND MAY NOT REFLECT CURRENT DESIGN STANDARDS

GREEN STORMWATER INFRASTRUCTURE PROJECT

BERKS AND SEDGLEY GREENING  
 BASE PLAN  
 W. BERKS STREET  
 N. 33RD ST. TO N. NATRONA ST.



PHILADELPHIA  
 WATER  
 DEPARTMENT

PLAN PREPARED FOR  
 THE CITY OF PHILADELPHIA  
 WATER DEPARTMENT BY:

DRAFT BASEPLAN  
 SUBMISSION <DATE>

INSERT COMPANY LOGO  
 AND ADDRESS HERE

PURSUANT TO THE REQUIREMENTS OF PENNSYLVANIA ACT 50 (2017), THE CONTRACTOR SHALL CONTACT THE PENNSYLVANIA ONE CALL SYSTEM AT 1-800-242-1776, AT LEAST 3 DAYS PRIOR TO EXCAVATION

HIGHWAY DISTRICT NO. 03 WARD NUMBER 28 & 32  
 SURVEY DISTRICT NO. 09 DRAINAGE SHT. NO. 40 & 41  
 OUTFALL NO. D39 & S05 PA ONE CALL 20160991564  
 20160991569  
 20160991600

APPROVED \_\_\_\_\_ CONSULTING ENGINEERING FIRM \_\_\_\_\_  
 CITY OF PHILADELPHIA  
 WATER DEPARTMENT

SCALES:  
 PLAN 1"=10'  
 PROFILE HORIZ. N/A  
 VERT. N/A  
 SECTION 1/4" = 1'

WORK NO. S-50179-G  
 SHEET NO. G-6 OF 19 SHEETS

|               |     |          |
|---------------|-----|----------|
| DRAWN BY      | CAD | XXX XXXX |
| PROJECT ENGR. |     | XXX XXXX |

CONTROLLING BENCH MARK

P.K. Nail at the Intersection of 32nd St. and Susquehanna Ave. Elevation = +112.35  
 P.K. Nail at the Intersection of 33rd St. and Montgomery Ave. Elevation = +111.67  
 P.K. Nail at the Intersection of 30th St. and Sedgley Ave. Elevation = +101.34

| #  | COMPONENT ID | COMPONENT TYPE                        | PIPE LENGTH (FT) |
|----|--------------|---------------------------------------|------------------|
| 1  |              | GREEN SHALLOW CITY INLET W/ APRON     | N/A              |
| 2  |              | GREEN SHALLOW CITY INLET W/ APRON     | N/A              |
| 3  |              | OMG INLET                             | N/A              |
| 4  |              | DISTRIBUTION PIPE                     | 12               |
| 5  |              | DISTRIBUTION PIPE                     | 40               |
| 6  |              | UNDERDRAIN                            | 33               |
| 7  |              | UNDERDRAIN                            | 40               |
| 8  |              | CONCRETE ENDWALL W/ ENERGY DISSIPATER | N/A              |
| 9  |              | CONCRETE ENDWALL W/ ENERGY DISSIPATER | N/A              |
| 10 |              | CLEANOUT                              | N/A              |
| 11 |              | OBSERVATION WELL                      | N/A              |
| 12 |              | DOMED RISER STANDPIPE                 | N/A              |
| 13 |              | 2'X4' OVERFLOW CONTROL STRUCTURE      | N/A              |

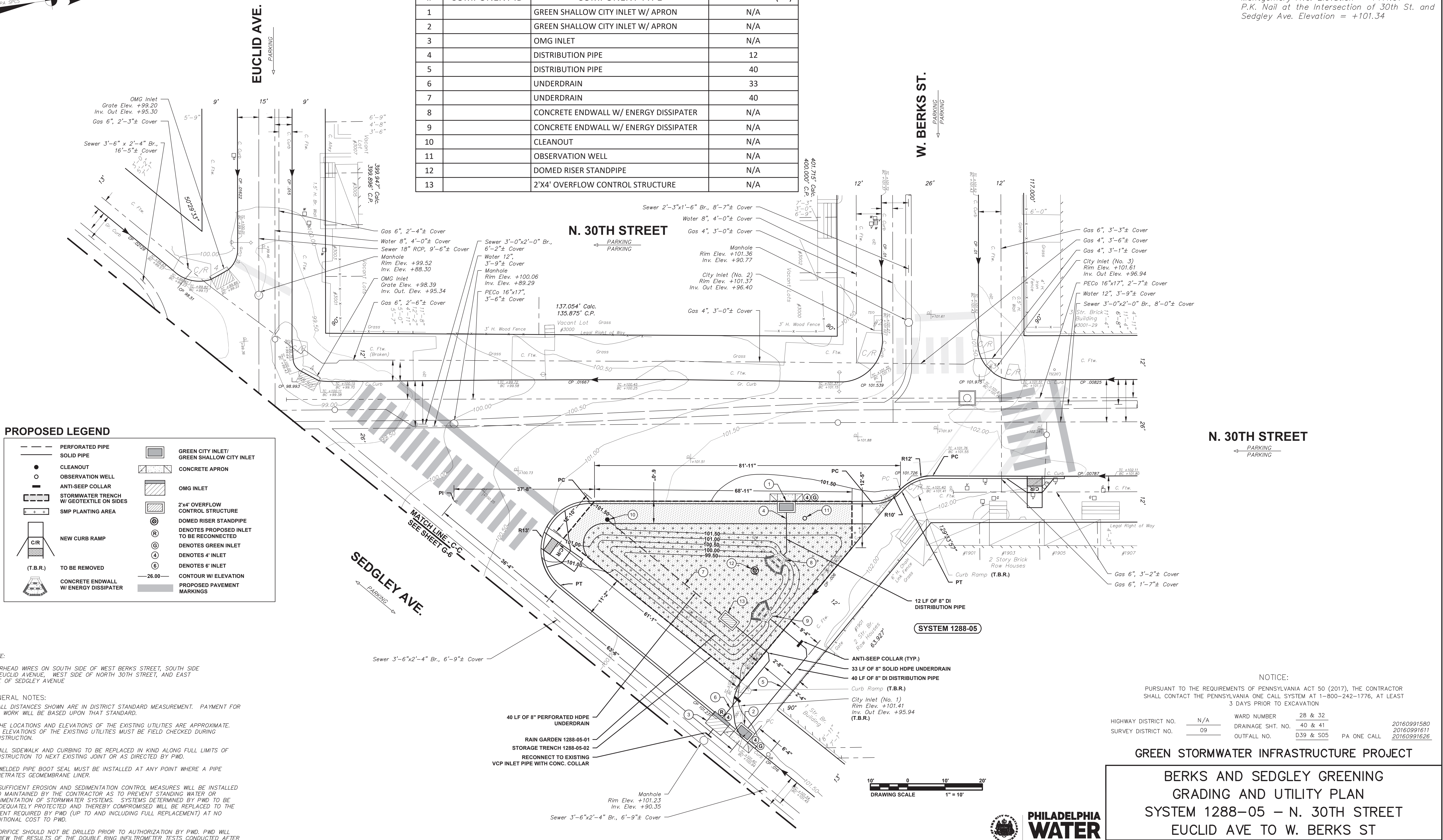
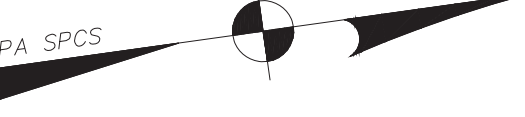

**PROPOSED LEGEND**

|  |  |  |   |
|--|--|--|---|
|  | PERFORATED PIPE                          |  | GREEN CITY INLET / GREEN SHALLOW CITY INLET |
|  | SOLID PIPE                               |  | CONCRETE APRON                              |
|  | CLEANOUT                                 |  | OMG INLET                                   |
|  | OBSERVATION WELL                         |  | 2'X4' OVERFLOW CONTROL STRUCTURE            |
|  | ANTI-SEEP COLLAR                         |  | DOMED RISER STANDPIPE                       |
|  | STORMWATER TRENCH W/ GEOTEXTILE ON SIDES |  | DENOTES PROPOSED INLET TO BE RECONNECTED    |
|  | SMP PLANTING AREA                        |  | DENOTES GREEN INLET                         |
|  | NEW CURB RAMP                            |  | DENOTES 4' INLET                            |
|  | TO BE REMOVED                            |  | DENOTES 6' INLET                            |
|  | CONCRETE ENDWALL W/ ENERGY DISSIPATER    |  | CONTOUR W/ ELEVATION                        |
|  |  |  | PROPOSED PAVEMENT MARKINGS                  |

- NOTE:**  
 OVERHEAD WIRES ON SOUTH SIDE OF WEST BERKS STREET, SOUTH SIDE OF EUCLID AVENUE, WEST SIDE OF NORTH 30TH STREET, AND EAST SIDE OF SEDGLEY AVENUE.
- GENERAL NOTES:**
- ALL DISTANCES SHOWN ARE IN DISTRICT STANDARD MEASUREMENT. PAYMENT FOR ALL WORK WILL BE BASED UPON THAT STANDARD.
  - THE LOCATIONS AND ELEVATIONS OF THE EXISTING UTILITIES ARE APPROXIMATE. THE ELEVATIONS OF THE EXISTING UTILITIES MUST BE FIELD CHECKED DURING CONSTRUCTION.
  - ALL SIDEWALK AND CURBING TO BE REPLACED IN KIND ALONG FULL LIMITS OF CONSTRUCTION TO NEXT EXISTING JOINT OR AS DIRECTED BY PWD.
  - WELDED PIPE BOOT SEAL MUST BE INSTALLED AT ANY POINT WHERE A PIPE PENETRATES GEOMEMBRANE LINER.
  - SUFFICIENT EROSION AND SEDIMENTATION CONTROL MEASURES WILL BE INSTALLED AND MAINTAINED BY THE CONTRACTOR AS TO PREVENT STANDING WATER OR SEDIMENTATION OF STORMWATER SYSTEMS. SYSTEMS DETERMINED BY PWD TO BE INADEQUATELY PROTECTED AND THEREBY COMPROMISED WILL BE REPLACED TO THE EXTENT REQUIRED BY PWD (UP TO AND INCLUDING FULL REPLACEMENT) AT NO ADDITIONAL COST TO PWD.
  - ORIFICE SHOULD NOT BE DRILLED PRIOR TO AUTHORIZATION BY PWD. PWD WILL REVIEW THE RESULTS OF THE DOUBLE RING INFILTRATOR TESTS CONDUCTED AFTER SMP EXCAVATION AND WILL CONFIRM ORIFICE DIMENSIONS.
  - EROSION CONTROL MATTING SHALL BE PLACED OVER ALL SOIL SURFACES NOT STABILIZED BY PLANTING.
  - SUPPORT AND PROTECT ALL UTILITIES, UTILITY POLES, OVERHEAD WIRES, TRAFFIC SIGNAGE, TRAFFIC SIGNALS, AND STREET LIGHTING WITHIN THE LIMITS OF WORK.
  - VERTICAL DATUM IS ON CITY OF PHILADELPHIA DATUM.
  - LINE AND GRADE STAKES FOR CURB, PAVING, ETC. WILL BE FURNISHED BY THE 9TH SURVEY DISTRICT OF THE CITY OF PHILADELPHIA. CONTACT INFORMATION: 9TH SURVEY DISTRICT, 4000 N. AMERICAN ST., PHILA., PA, 19140, (215) 685-3050
  - NOTIFY THE 9TH SURVEY DISTRICT A MINIMUM OF TWO (2) WEEKS PRIOR TO THE START OF WORK TO SCHEDULE A TIME FOR CURB STAKE LAYOUT SERVICES.

**NOTICE:**  
 PURSUANT TO THE REQUIREMENTS OF PENNSYLVANIA ACT 50 (2017), THE CONTRACTOR SHALL CONTACT THE PENNSYLVANIA ONE CALL SYSTEM AT 1-800-242-1776, AT LEAST 3 DAYS PRIOR TO EXCAVATION.

HIGHWAY DISTRICT NO. N/A WARD NUMBER 28 & 32  
 SURVEY DISTRICT NO. 09 DRAINAGE SHT. NO. 40 & 41 20160991580  
 20160991611  
 OUTFALL NO. D39 & S05 PA ONE CALL 20160991626

**GREEN STORMWATER INFRASTRUCTURE PROJECT**

**BERKS AND SEDGLEY GREENING GRADING AND UTILITY PLAN SYSTEM 1288-05 - N. 30TH STREET EUCLID AVE TO W. BERKS ST**

EXAMPLE PLAN 2021 - NOT FOR CONSTRUCTION  
 THIS PLAN WAS DEVELOPED TO DEMONSTRATE DRAWING STANDARDS AND MAY NOT REFLECT CURRENT DESIGN STANDARDS

**DRAFT PRELIMINARY DESIGN SUBMISSION <DATE>**



**PHILADELPHIA WATER DEPARTMENT**  
 PLAN PREPARED FOR THE CITY OF PHILADELPHIA WATER DEPARTMENT BY:

|                            |                             |                                       |
|----------------------------|-----------------------------|---------------------------------------|
| APPROVED                   | CONSULTING ENGINEERING FIRM | CITY OF PHILADELPHIA WATER DEPARTMENT |
| SCALE:                     |                             | PLAN 1"=10'                           |
| PROFILE                    | HORIZ.                      | N/A                                   |
|                            | VERT.                       | N/A                                   |
| SECTION                    |                             | N/A                                   |
| DRAWN BY: CAD              |                             | XXX XXXX                              |
| PROJECT ENGR: PROJECT ENGR |                             | XXX XXXX                              |
| WORK NO. S-50179-G         |                             |                                       |
| SHEET NO. G-5 OF 14 SHEETS |                             |                                       |

INSERT COMPANY LOGO AND ADDRESS HERE

CONTROLLING BENCH MARK

F. Hyd. rim on the intersection of Rising Sun Avenue and Godfrey Street  
Elev. = 121.29

PROPOSED LEGEND

|  |   |  |   |
|--|---|--|---|
|  | PERFORATED PIPE                                       |  | CITY INLET                                    |
|  | SOLID PIPE  |  | GREEN CITY INLET/<br>GREEN SHALLOW CITY INLET |
|  | CLEANOUT  |  | CONCRETE APRON                                |
|  | OBSERVATION WELL                                      |  | HIGHWAY GRATE INLET                           |
|  | ANTI-SEEP COLLAR                                      |  | GREEN HIGHWAY GRATE INLET                     |
|  | STORMWATER TRENCH<br>W/ GEOTEXTILE ON SIDES           |  | TREE PIT                                      |
|  | STORMWATER TRENCH<br>W/ GEOMEMBRANE LINER<br>ON SIDES |  | DENOTES PROPOSED INLET                        |
|  | SMP PLANTING AREA                                     |  | DENOTES RECONNECTED<br>INLET                  |
|  | GEOMEMBRANE LINER<br>ON BOTTOM                        |  | DENOTES GREEN INLET                           |
|  | NEW CURB RAMP   |  | DENOTES 4" INLET                              |
|  | TO BE REMOVED   |  | DENOTES 6" INLET                              |

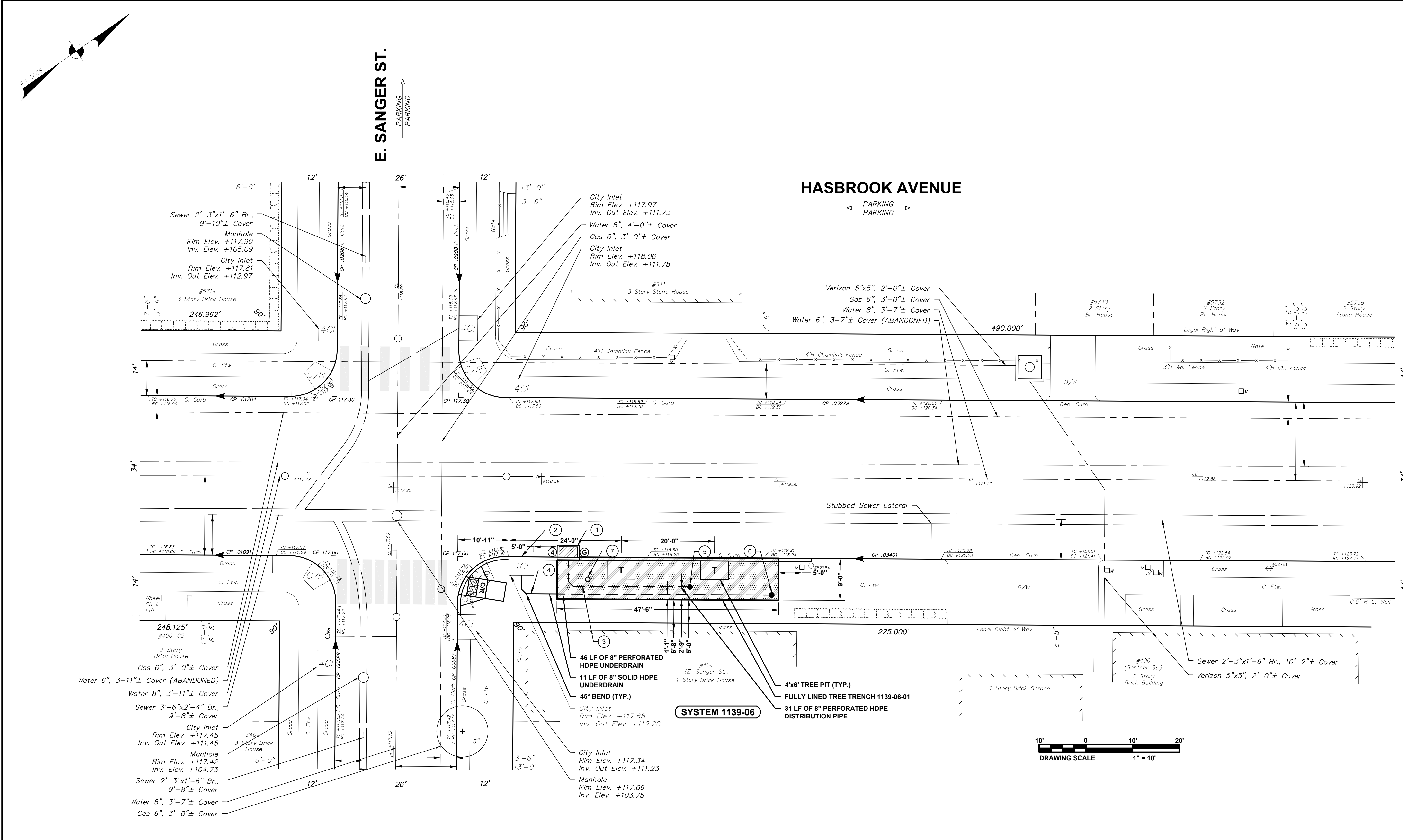

- NOTE:  
OVERHEAD WIRES ON EAST SIDE OF HASBROOK AVENUE AND NORTH SIDE OF EAST SANGER STREET
- GENERAL NOTES:
- ALL DISTANCES SHOWN ARE IN DISTRICT STANDARD MEASUREMENT. PAYMENT FOR ALL WORK WILL BE BASED UPON THAT STANDARD.
  - THE LOCATIONS AND ELEVATIONS OF THE EXISTING UTILITIES ARE APPROXIMATE. THE ELEVATIONS OF THE EXISTING UTILITIES MUST BE FIELD CHECKED DURING CONSTRUCTION.
  - ALL SIDEWALK AND CURBING TO BE REPLACED IN KIND ALONG FULL LIMITS OF CONSTRUCTION TO NEXT EXISTING JOINT OR AS DIRECTED BY PWD.
  - WELDED PIPE BOOT SEAL MUST BE INSTALLED AT ANY POINT WHERE A PIPE PENETRATES GEOMEMBRANE LINER.
  - SUFFICIENT EROSION AND SEDIMENTATION CONTROL MEASURES WILL BE INSTALLED AND MAINTAINED BY THE CONTRACTOR AS TO PREVENT STANDING WATER OR SEDIMENTATION OF STORMWATER SYSTEMS. SYSTEMS DETERMINED BY PWD TO BE INADEQUATELY PROTECTED AND THEREBY COMPROMISED WILL BE REPLACED TO THE EXTENT REQUIRED BY PWD (UP TO AND INCLUDING FULL REPLACEMENT) AT NO ADDITIONAL COST TO PWD.
  - ORIFICE SHOULD NOT BE DRILLED PRIOR TO AUTHORIZATION BY PWD. PWD WILL REVIEW THE RESULTS OF THE DOUBLE RING INFILTRATOR TESTS CONDUCTED AFTER SMP EXCAVATION AND WILL CONFIRM ORIFICE DIMENSIONS.
  - EROSION CONTROL MATTING SHALL BE PLACED OVER ALL SOIL SURFACES NOT STABILIZED BY PLANTING.
  - SUPPORT AND PROTECT ALL UTILITIES, UTILITY POLES, OVERHEAD WIRES, TRAFFIC SIGNAGE, TRAFFIC SIGNALS, AND STREET LIGHTING WITHIN THE LIMITS OF WORK.
  - VERTICAL DATUM IS ON CITY OF PHILADELPHIA DATUM.
  - LINE AND GRADE STAKES FOR CURB, PAVING, ETC. WILL BE FURNISHED BY THE 5TH SURVEY DISTRICT OF THE CITY OF PHILADELPHIA. CONTACT INFORMATION: 5TH SURVEY DISTRICT, 6601 RISING SUN AVE., PHILA., PA, 19111, (215) 685-0585.
  - NOTIFY THE 5TH SURVEY DISTRICT A MINIMUM OF TWO (2) WEEKS PRIOR TO THE START OF WORK TO SCHEDULE A TIME FOR CURB STAKE LAYOUT SERVICES.

NOTICE:  
PURSUANT TO THE REQUIREMENTS OF PENNSYLVANIA ACT 50 (2017), THE CONTRACTOR SHALL CONTACT THE PENNSYLVANIA ONE CALL SYSTEM AT 1-800-242-1776, AT LEAST 3 DAYS PRIOR TO EXCAVATION

HIGHWAY DISTRICT NO. 05 WARD NUMBER 35  
SURVEY DISTRICT NO. 05 DRAINAGE SHT. NO. 80  
OUTFALL NO. T-06 PA ONE CALL 20152221167  
20152221447

| # | COMPONENT ID | COMPONENT TYPE        | PIPE LENGTH (FT) |
|---|--------------|-----------------------|------------------|
| 1 |              | GREEN HWY GRATE INLET | N/A              |
| 2 |              | CITY INLET            | N/A              |
| 3 |              | DISTRIBUTION PIPE     | 31               |
| 4 |              | UNDERDRAIN            | 57               |
| 5 |              | CLEANOUT              | N/A              |
| 6 |              | CLEANOUT              | N/A              |
| 7 |              | OBSERVATION WELL      | N/A              |

GREEN STORMWATER INFRASTRUCTURE PROJECT

LAWNCREST STREETS SOUTHWEST  
GRADING & UTILITY PLAN- SYSTEM 1139-06  
HASBROOK AVENUE  
E. SANGER ST. TO SENTNER ST.



PHILADELPHIA  
WATER  
DEPARTMENT

EXAMPLE PLAN 2021 - NOT FOR CONSTRUCTION  
THIS PLAN WAS DEVELOPED TO DEMONSTRATE DRAWING STANDARDS  
AND MAY NOT REFLECT CURRENT DESIGN STANDARDS

DRAFT PRELIMINARY DESIGN  
SUBMISSION <DATE>

INSERT COMPANY LOGO  
AND ADDRESS HERE

APPROVED \_\_\_\_\_ CONSULTING ENGINEERING FIRM \_\_\_\_\_

CITY OF PHILADELPHIA  
WATER DEPARTMENT

PLAN PREPARED FOR THE CITY OF PHILADELPHIA WATER DEPARTMENT BY:

SCALES:  
PLAN 1"=10'  
PROFILE HORIZ. N/A  
VERT. N/A  
SECTION N/A

WORK NO. S-50179-G  
SHEET NO. G-13 OF 67 SHEETS

|               |               |          |
|---------------|---------------|----------|
| DRAWN BY      | CAD           | XXX XXXX |
| PROJECT ENGR. | PROJECT ENGR. | XXX XXXX |

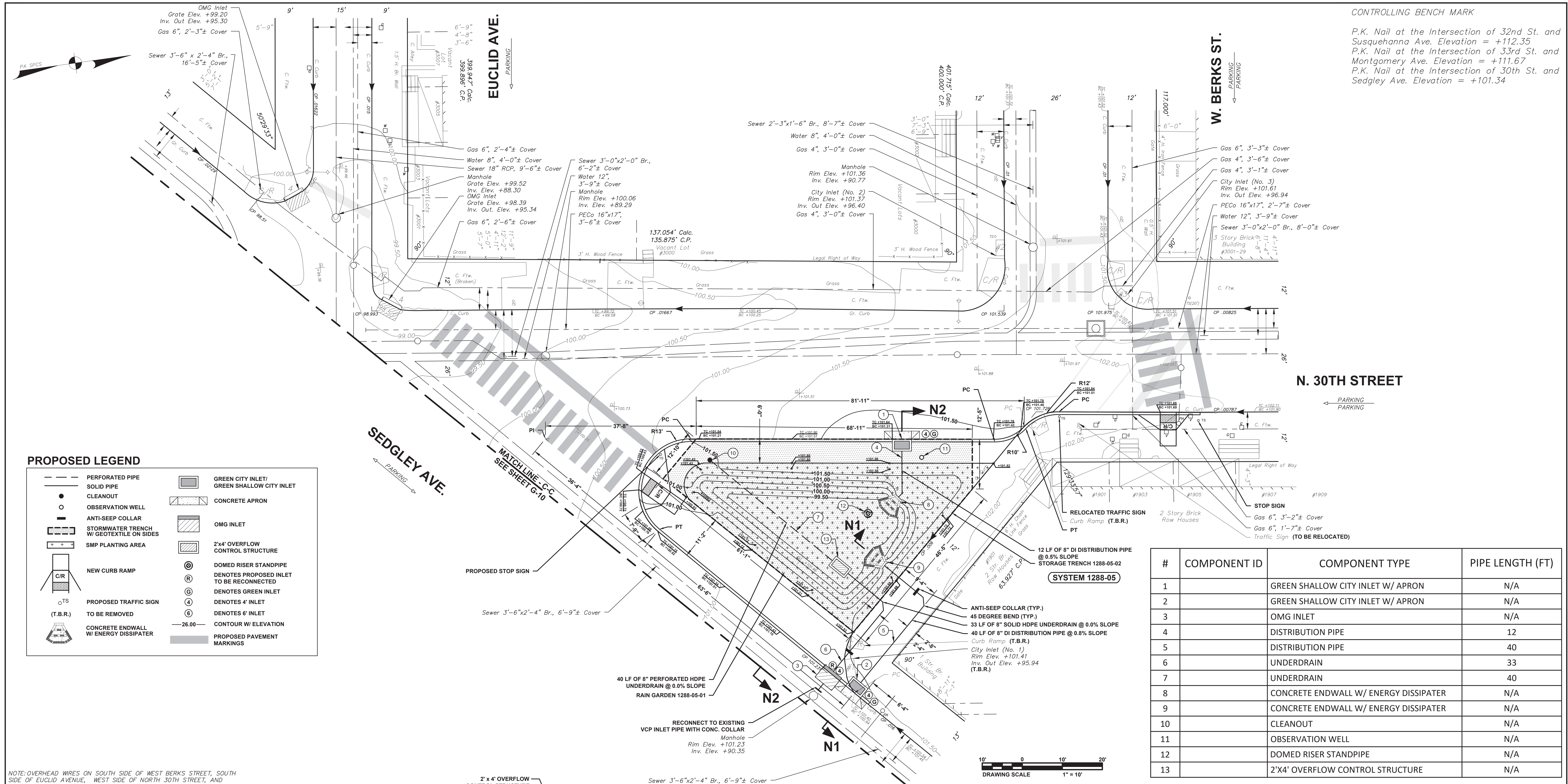

CONTROLLING BENCH MARK  
 P.K. Nail at the Intersection of 32nd St. and Susquehanna Ave. Elevation = +112.35  
 P.K. Nail at the Intersection of 33rd St. and Montgomery Ave. Elevation = +111.67  
 P.K. Nail at the Intersection of 30th St. and Sedgley Ave. Elevation = +101.34

**PROPOSED LEGEND**

|  |  |  |  |
|--|--|--|--|
|  | PERFORATED PIPE                              |  | GREEN CITY INLET/ GREEN SHALLOW CITY INLET |
|  | SOLID PIPE                                   |  | CONCRETE APRON                             |
|  | CLEANOUT                                     |  | OMG INLET                                  |
|  | OBSERVATION WELL                             |  | 2'x4' OVERFLOW CONTROL STRUCTURE           |
|  | ANTI-SEEP COLLAR                             |  | DOMED RISER STANDPIPE                      |
|  | STORMWATER TRENCH W/ GEOTEXTILE ON SIDES     |  | DENOTES PROPOSED INLET TO BE RECONNECTED   |
|  | SMP PLANTING AREA                            |  | DENOTES GREEN INLET                        |
|  | NEW CURB RAMP                                |  | DENOTES 4' INLET                           |
|  | PROPOSED TRAFFIC SIGN TO BE REMOVED (T.B.R.) |  | DENOTES 6' INLET                           |
|  | CONCRETE ENDWALL W/ ENERGY DISSIPATER        |  | CONTOUR W/ ELEVATION                       |
|  |  |  | PROPOSED PAVEMENT MARKINGS                 |

| #  | COMPONENT ID | COMPONENT TYPE                        | PIPE LENGTH (FT) |
|----|--------------|---------------------------------------|------------------|
| 1  |              | GREEN SHALLOW CITY INLET W/ APRON     | N/A              |
| 2  |              | GREEN SHALLOW CITY INLET W/ APRON     | N/A              |
| 3  |              | OMG INLET                             | N/A              |
| 4  |              | DISTRIBUTION PIPE                     | 12               |
| 5  |              | DISTRIBUTION PIPE                     | 40               |
| 6  |              | UNDERDRAIN                            | 33               |
| 7  |              | UNDERDRAIN                            | 40               |
| 8  |              | CONCRETE ENDWALL W/ ENERGY DISSIPATER | N/A              |
| 9  |              | CONCRETE ENDWALL W/ ENERGY DISSIPATER | N/A              |
| 10 |              | CLEANOUT                              | N/A              |
| 11 |              | OBSERVATION WELL                      | N/A              |
| 12 |              | DOMED RISER STANDPIPE                 | N/A              |
| 13 |              | 2'x4' OVERFLOW CONTROL STRUCTURE      | N/A              |

- NOTE: OVERHEAD WIRES ON SOUTH SIDE OF WEST BERKS STREET, SOUTH SIDE OF EUCLID AVENUE, WEST SIDE OF NORTH 30TH STREET, AND EAST SIDE OF SEDGLEY AVENUE.
- GENERAL NOTES:**
- ALL DISTANCES SHOWN ARE IN DISTRICT STANDARD MEASUREMENT. PAYMENT FOR ALL WORK WILL BE BASED UPON THAT STANDARD.
  - THE LOCATIONS AND ELEVATIONS OF THE EXISTING UTILITIES ARE APPROXIMATE. THE ELEVATIONS OF THE EXISTING UTILITIES MUST BE FIELD CHECKED DURING CONSTRUCTION.
  - ALL SIDEWALK AND CURBING TO BE REPLACED IN KIND ALONG FULL LIMITS OF CONSTRUCTION TO NEXT EXISTING JOINT OR AS DIRECTED BY PWD.
  - WELDED PIPE BOOT SEAL MUST BE INSTALLED AT ANY POINT WHERE A PIPE PENETRATES GEOMEMBRANE LINER.
  - SUFFICIENT EROSION AND SEDIMENTATION CONTROL MEASURES WILL BE INSTALLED AND MAINTAINED BY THE CONTRACTOR AS TO PREVENT STANDING WATER OR SEDIMENTATION OF STORMWATER SYSTEMS. SYSTEMS DETERMINED BY PWD TO BE INADEQUATELY PROTECTED AND THEREBY COMPROMISED WILL BE REPLACED TO THE EXTENT REQUIRED BY PWD (UP TO AND INCLUDING FULL REPLACEMENT) AT NO ADDITIONAL COST TO PWD.
  - ORIFICE SHOULD NOT BE DRILLED PRIOR TO AUTHORIZATION BY PWD. PWD WILL REVIEW THE RESULTS OF THE DOUBLE RING INFILTRATOR TESTS CONDUCTED AFTER SMP EXCAVATION AND WILL CONFIRM ORIFICE DIMENSIONS.
  - EROSION CONTROL MATTING SHALL BE PLACED OVER ALL SOIL SURFACES NOT STABILIZED BY PLANTING.
  - SUPPORT AND PROTECT ALL UTILITIES, UTILITY POLES, OVERHEAD WIRES, TRAFFIC SIGNAGE, TRAFFIC SIGNALS, AND STREET LIGHTING WITHIN THE LIMITS OF WORK.
  - VERTICAL DATUM IS ON CITY OF PHILADELPHIA DATUM
  - LINE AND GRADE STAKES FOR CURB, PAVING, ETC. WILL BE FURNISHED BY THE 9TH SURVEY DISTRICT OF THE CITY OF PHILADELPHIA. CONTACT INFORMATION: 9TH SURVEY DISTRICT, 4000 N. AMERICAN ST., PHILA., PA, 19140, (215) 685-3050
  - NOTIFY THE 9TH SURVEY DISTRICT A MINIMUM OF TWO (2) WEEKS PRIOR TO THE START OF WORK TO SCHEDULE A TIME FOR CURB STAKE LAYOUT SERVICES.

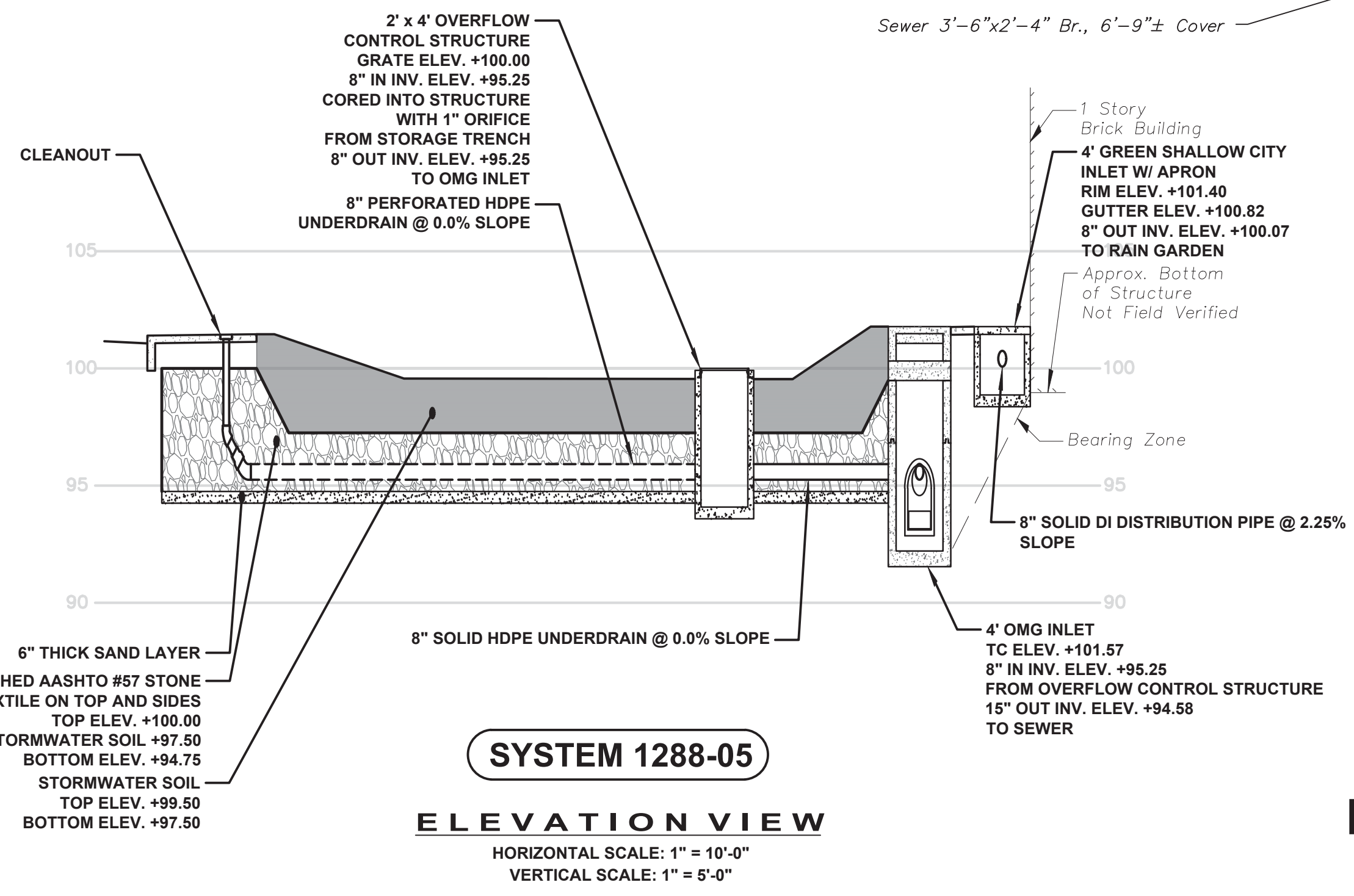

EXAMPLE PLAN 2021 - NOT FOR CONSTRUCTION  
 THIS PLAN WAS DEVELOPED TO DEMONSTRATE DRAWING STANDARDS  
 AND MAY NOT REFLECT CURRENT DESIGN STANDARDS

**DRAFT SUBSTANTIALLY COMPLETE  
 DESIGN SUBMISSION <DATE>**

**NOTICE:**  
 PURSUANT TO THE REQUIREMENTS OF PENNSYLVANIA ACT 50 (2017), THE CONTRACTOR SHALL CONTACT THE PENNSYLVANIA ONE CALL SYSTEM AT 1-800-242-1776, AT LEAST 3 DAYS PRIOR TO EXCAVATION

HIGHWAY DISTRICT NO. 03 WARD NUMBER 28 & 32  
 SURVEY DISTRICT NO. 09 DRAINAGE SHT. NO. 40 & 41  
 OUTFALL NO. D39 & S05 PA ONE CALL

20160991580  
 20160991611  
 20160991626

**GREEN STORMWATER INFRASTRUCTURE PROJECT**

**BERKS AND SEDGLEY GREENING  
 GRADING AND UTILITY PLAN  
 SYSTEM 1288-05 - N. 30TH STREET  
 EUCLID AVE TO W. BERKS ST**



APPROVED \_\_\_\_\_ CONSULTING ENGINEERING FIRM \_\_\_\_\_

PLAN PREPARED FOR THE CITY OF PHILADELPHIA WATER DEPARTMENT BY: \_\_\_\_\_

CITY OF PHILADELPHIA WATER DEPARTMENT

SCALE: PLAN 1"=10'  
 PROFILE HORIZ. 1"=10'  
 VERT. 1"=5'  
 SECTION 1/4"=1'-0"

WORK NO. S-50179-G  
 SHEET NO. G-7 OF 19 SHEETS

DRAWN BY: CAD PROJECT ENGR. XXX XXXX  
 PROJECT ENGR. PROJECT ENGR. XXX XXXX

INSERT COMPANY LOGO AND ADDRESS HERE

CONTROLLING BENCH MARK

P.K. Nail at the Intersection of 32nd St. and Susquehanna Ave. Elevation = +112.35  
 P.K. Nail at the Intersection of 33rd St. and Montgomery Ave. Elevation = +111.67  
 P.K. Nail at the Intersection of 30th St. and Sedgley Ave. Elevation = +101.34

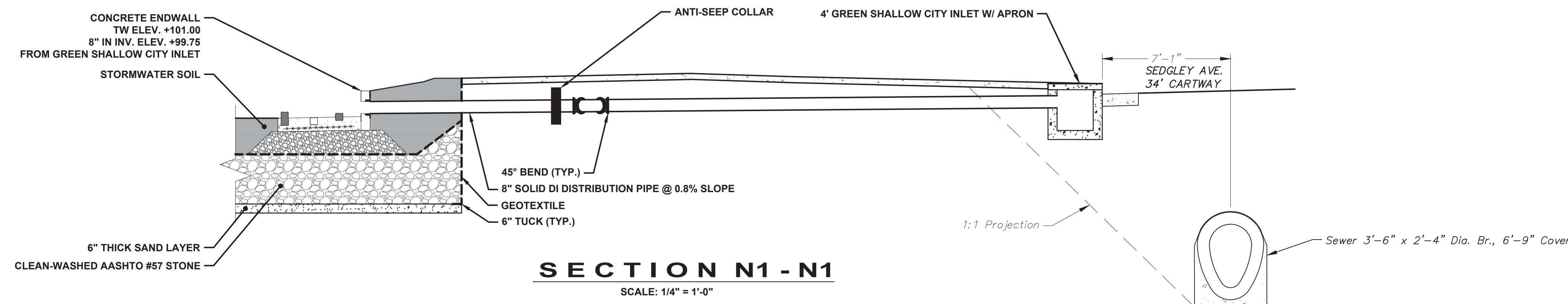

**SECTION N1 - N1**  
 SCALE: 1/4" = 1'-0"

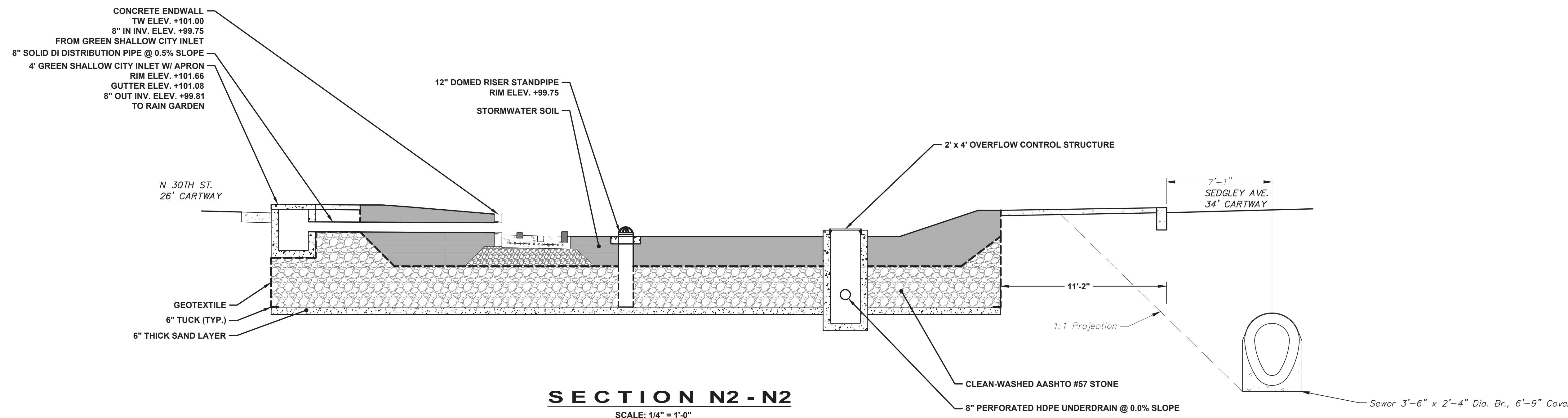

**SECTION N2 - N2**  
 SCALE: 1/4" = 1'-0"

**GENERAL NOTES:**

- ALL DISTANCES SHOWN ARE IN DISTRICT STANDARD MEASUREMENT. PAYMENT FOR ALL WORK WILL BE BASED UPON THAT STANDARD.
- THE LOCATIONS AND ELEVATIONS OF THE EXISTING UTILITIES ARE APPROXIMATE. THE ELEVATIONS OF THE EXISTING UTILITIES MUST BE FIELD CHECKED DURING CONSTRUCTION.
- ALL SIDEWALK AND CURBING TO BE REPLACED IN KIND ALONG FULL LIMITS OF CONSTRUCTION TO NEXT EXISTING JOINT OR AS DIRECTED BY PWD.
- WELDED PIPE BOOT SEAL MUST BE INSTALLED AT ANY POINT WHERE A PIPE PENETRATES GEOMEMBRANE LINER.
- SUFFICIENT EROSION AND SEDIMENTATION CONTROL MEASURES WILL BE INSTALLED AND MAINTAINED BY THE CONTRACTOR AS TO PREVENT STANDING WATER OR SEDIMENTATION OF STORMWATER SYSTEMS. SYSTEMS DETERMINED BY PWD TO BE INADEQUATELY PROTECTED AND THEREBY COMPROMISED WILL BE REPLACED TO THE EXTENT REQUIRED BY PWD (UP TO AND INCLUDING FULL REPLACEMENT) AT NO ADDITIONAL COST TO PWD.
- ORIFICE SHOULD NOT BE DRILLED PRIOR TO AUTHORIZATION BY PWD. PWD WILL REVIEW THE RESULTS OF THE DOUBLE RING INFILTRMETER TESTS CONDUCTED AFTER SMP EXCAVATION AND WILL CONFIRM ORIFICE DIMENSIONS.
- EROSION CONTROL MATTING SHALL BE PLACED OVER ALL SOIL SURFACES NOT STABILIZED BY PLANTING.
- SUPPORT AND PROTECT ALL UTILITIES, UTILITY POLES, OVERHEAD WIRES, TRAFFIC SIGNAGE, TRAFFIC SIGNALS, AND STREET LIGHTING WITHIN THE LIMITS OF WORK.
- VERTICAL DATUM IS ON CITY OF PHILADELPHIA DATUM
- LINE AND GRADE STAKES FOR CURB, PAVING, ETC. WILL BE FURNISHED BY THE 9TH SURVEY DISTRICT OF THE CITY OF PHILADELPHIA. CONTACT INFORMATION: 9TH SURVEY DISTRICT, 4000 N. AMERICAN ST., PHILA., PA, 19140, (215) 685-3050
- NOTIFY THE 9TH SURVEY DISTRICT A MINIMUM OF TWO (2) WEEKS PRIOR TO THE START OF WORK TO SCHEDULE A TIME FOR CURB STAKE LAYOUT SERVICES.

**NOTICE:**

PURSUANT TO THE REQUIREMENTS OF PENNSYLVANIA ACT 50 (2017), THE CONTRACTOR SHALL CONTACT THE PENNSYLVANIA ONE CALL SYSTEM AT 1-800-242-1776, AT LEAST 3 DAYS PRIOR TO EXCAVATION

|                      |    |                   |             |             |
|----------------------|----|-------------------|-------------|-------------|
| HIGHWAY DISTRICT NO. | 03 | WARD NUMBER       | 28 & 32     |             |
| SURVEY DISTRICT NO.  | 09 | DRAINAGE SHT. NO. | 40 & 41     | 20160991580 |
|                      |    | OUTFALL NO.       | D39 & S05   | 20160991611 |
|                      |    |                   | PA ONE CALL | 20160991626 |

**GREEN STORMWATER INFRASTRUCTURE PROJECT**

**BERKS AND SEDGLEY GREENING  
 GRADING AND UTILITY PLAN  
 SYSTEM 1288-05 - N. 30TH STREET  
 EUCLID AVE TO W. BERKS ST**



**PHILADELPHIA  
 WATER  
 DEPARTMENT**  
 PLAN PREPARED FOR  
 THE CITY OF PHILADELPHIA  
 WATER DEPARTMENT BY:

EXAMPLE PLAN 2021 - NOT FOR CONSTRUCTION  
 THIS PLAN WAS DEVELOPED TO DEMONSTRATE DRAWING STANDARDS  
 AND MAY NOT REFLECT CURRENT DESIGN STANDARDS

**DRAFT SUBSTANTIALLY COMPLETE  
 DESIGN SUBMISSION <DATE>**

INSERT COMPANY LOGO  
 AND ADDRESS HERE

APPROVED \_\_\_\_\_  
 CONSULTING ENGINEERING FIRM

CITY OF PHILADELPHIA  
 WATER DEPARTMENT

SCALES:

|         |               |
|---------|---------------|
| PLAN    | 1"=10'        |
| PROFILE | HORIZ. 1"=10' |
|         | VERT. 1"=5'   |
| SECTION | 1/4"=1'-0"    |

WORK NO. S-50179-G

SHEET NO. G-8 OF 19 SHEETS

|               |               |          |
|---------------|---------------|----------|
| DRAWN BY      | CAD           | XXX XXXX |
| PROJECT ENGR. | PROJECT ENGR. | XXX XXXX |



CONTROLLING BENCH MARK

F. Hyd. rim on the intersection of Rising Sun Avenue and Godfrey Street Elev. = 121.29

**PROPOSED LEGEND**

|  |   |  |  |
|--|---|--|--|
|  | PERFORATED PIPE                                 |  | CITY INLET                                 |
|  | SOLID PIPE                                      |  | GREEN CITY INLET/ GREEN SHALLOW CITY INLET |
|  | CLEANOUT  |  | CONCRETE APRON                             |
|  | OBSERVATION WELL                                |  | HIGHWAY GRATE INLET                        |
|  | STORMWATER TRENCH W/ GEOTEXTILE ON SIDES        |  | GREEN HIGHWAY GRATE INLET                  |
|  | STORMWATER TRENCH W/ GEOMEMBRANE LINER ON SIDES |  | TREE PIT                                   |
|  | SMP PLANTING AREA                               |  | DENOTES PROPOSED INLET TO BE RECONNECTED   |
|  | GEOMEMBRANE LINER ON BOTTOM                     |  | DENOTES GREEN INLET                        |
|  | NEW CURB RAMP                                   |  | DENOTES 4" INLET                           |
|  | (T.B.R.) TO BE REMOVED                          |  | DENOTES 6" INLET                           |

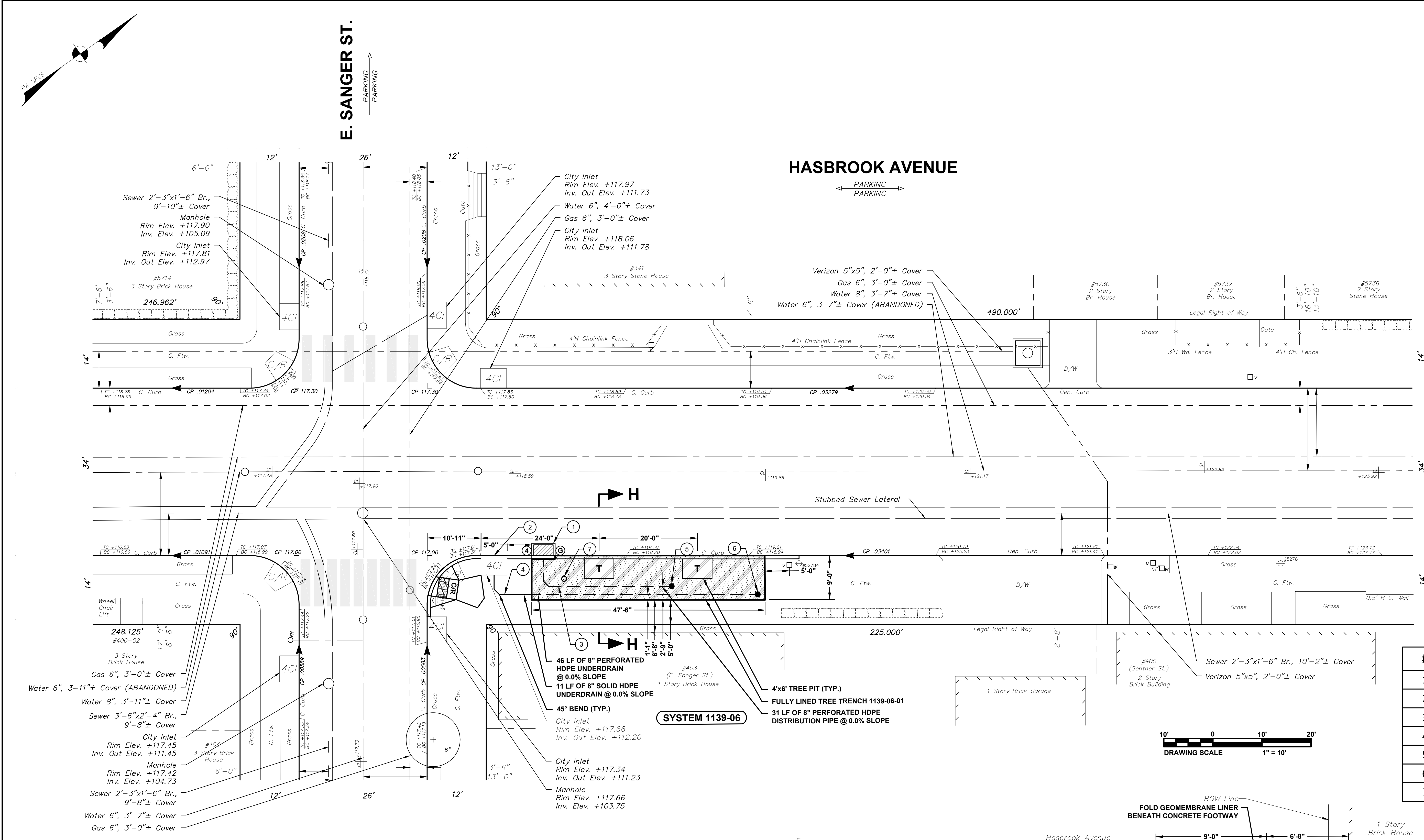

| # | COMPONENT ID | COMPONENT TYPE        | PIPE LENGTH (FT) |
|---|--------------|-----------------------|------------------|
| 1 |              | GREEN HWY GRATE INLET | N/A              |
| 2 |              | CITY INLET            | N/A              |
| 3 |              | DISTRIBUTION PIPE     | 31               |
| 4 |              | UNDERDRAIN            | 57               |
| 5 |              | CLEANOUT              | N/A              |
| 6 |              | CLEANOUT              | N/A              |
| 7 |              | OBSERVATION WELL      | N/A              |

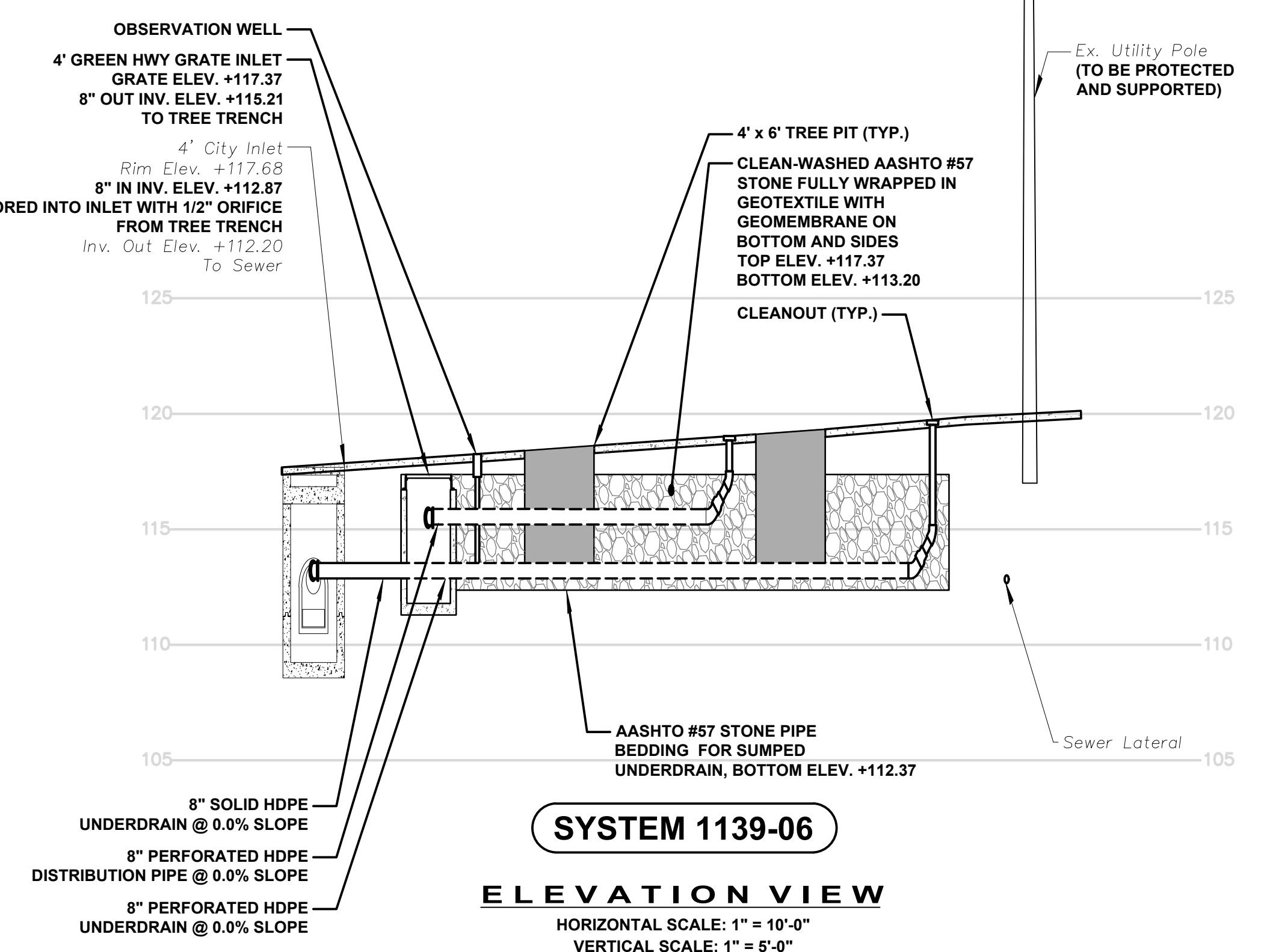
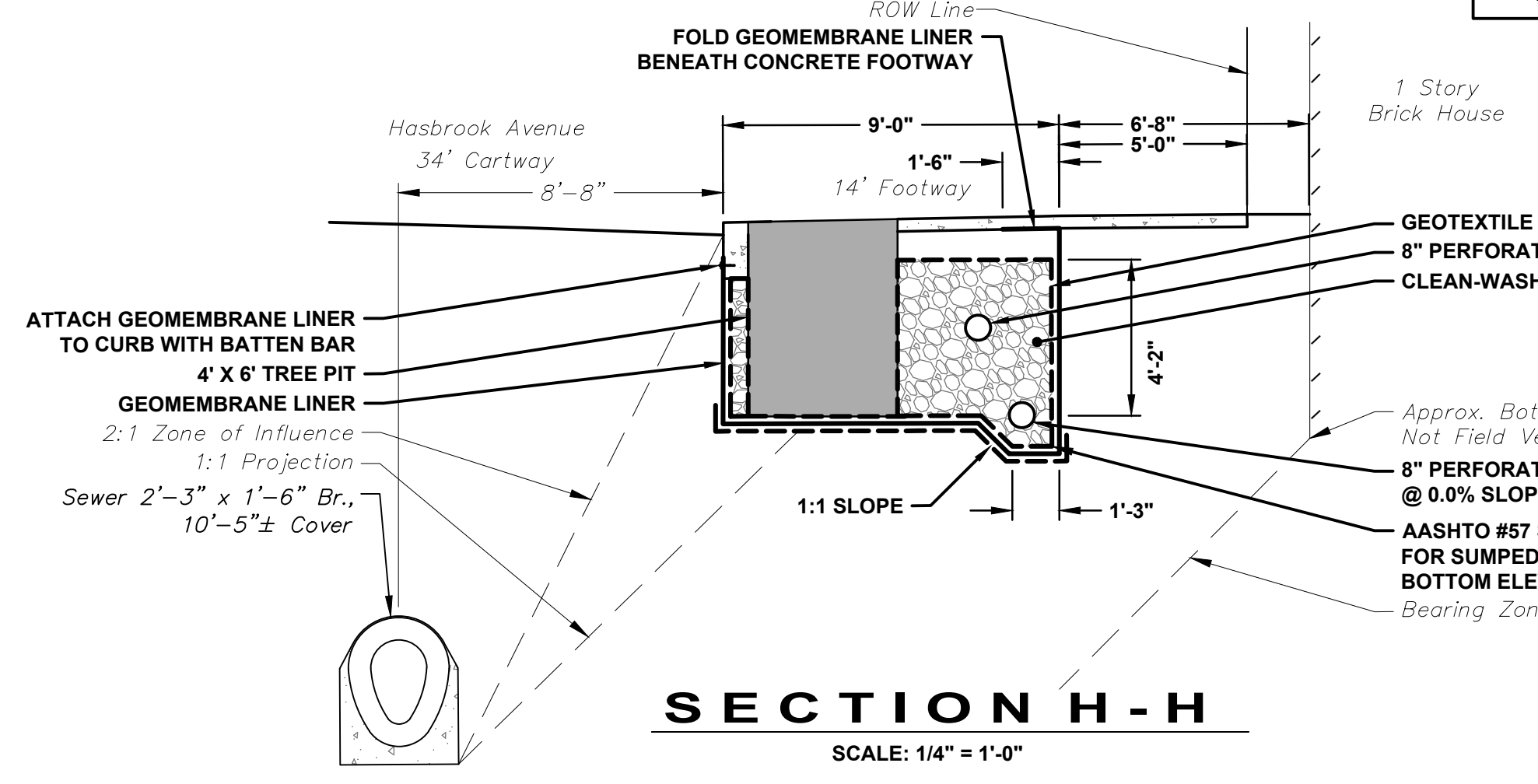
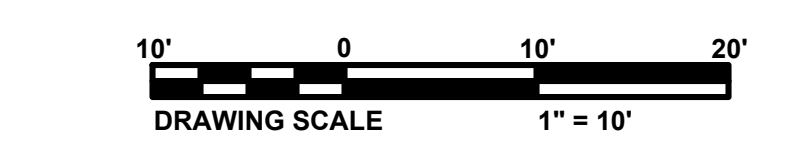

- NOTE:  
OVERHEAD WIRES ON EAST SIDE OF HASBROOK AVENUE AND NORTH SIDE OF EAST SANGER STREET
- GENERAL NOTES:
- ALL DISTANCES SHOWN ARE IN DISTRICT STANDARD MEASUREMENT. PAYMENT FOR ALL WORK WILL BE BASED UPON THAT STANDARD.
  - THE LOCATIONS AND ELEVATIONS OF THE EXISTING UTILITIES ARE APPROXIMATE. THE ELEVATIONS OF THE EXISTING UTILITIES MUST BE FIELD CHECKED DURING CONSTRUCTION.
  - ALL SIDEWALK AND CURBING TO BE REPLACED IN KIND ALONG FULL LIMITS OF CONSTRUCTION TO NEXT EXISTING JOINT OR AS DIRECTED BY PWD.
  - WELDED PIPE BOOT SEAL MUST BE INSTALLED AT ANY POINT WHERE A PIPE PENETRATES GEOMEMBRANE LINER.
  - SUFFICIENT EROSION AND SEDIMENTATION CONTROL MEASURES WILL BE INSTALLED AND MAINTAINED BY THE CONTRACTOR AS TO PREVENT STANDING WATER OR SEDIMENTATION OF STORMWATER SYSTEMS. SYSTEMS DETERMINED BY PWD TO BE INADEQUATELY PROTECTED AND THEREBY COMPROMISED WILL BE REPLACED TO THE EXTENT REQUIRED BY PWD (UP TO AND INCLUDING FULL REPLACEMENT) AT NO ADDITIONAL COST TO PWD.
  - ORIFICE SHOULD NOT BE DRILLED PRIOR TO AUTHORIZATION BY PWD. PWD WILL REVIEW THE RESULTS OF THE DOUBLE RING INFILTRMETER TESTS CONDUCTED AFTER SMP EXCAVATION AND WILL CONFIRM ORIFICE DIMENSIONS.
  - EROSION CONTROL MATTING SHALL BE PLACED OVER ALL SOIL SURFACES NOT STABILIZED BY PLANTING.
  - SUPPORT AND PROTECT ALL UTILITIES, UTILITY POLES, OVERHEAD WIRES, TRAFFIC SIGNAGE, TRAFFIC SIGNALS, AND STREET LIGHTING WITHIN THE LIMITS OF WORK.
  - VERTICAL DATUM IS ON CITY OF PHILADELPHIA DATUM.
  - LINE AND GRADE STAKES FOR CURB, PAVING, ETC. WILL BE FURNISHED BY THE 5TH SURVEY DISTRICT OF THE CITY OF PHILADELPHIA. CONTACT INFORMATION: 5TH SURVEY DISTRICT, 6601 RISING SUN AVE., PHILA., PA, 19111, (215) 685-0585
  - NOTIFY THE 5TH SURVEY DISTRICT A MINIMUM OF TWO (2) WEEKS PRIOR TO THE START OF WORK TO SCHEDULE A TIME FOR CURB STAKE LAYOUT SERVICES.

NOTICE:  
PURSUANT TO THE REQUIREMENTS OF PENNSYLVANIA ACT 50 (2017), THE CONTRACTOR SHALL CONTACT THE PENNSYLVANIA ONE CALL SYSTEM AT 1-800-242-1776, AT LEAST 3 DAYS PRIOR TO EXCAVATION

|                      |    |                   |      |
|----------------------|----|-------------------|------|
| HIGHWAY DISTRICT NO. | 05 | WARD NUMBER       | 35   |
| SURVEY DISTRICT NO.  | 05 | DRAINAGE SHT. NO. | 80   |
|                      |    | OUTFALL NO.       | T-06 |

PA ONE CALL 20152221167  
20152221447

**GREEN STORMWATER INFRASTRUCTURE PROJECT**

**LAWNCREST STREETS SOUTHWEST  
GRADING & UTILITY PLAN- SYSTEM 1139-06  
HASBROOK AVENUE  
E. SANGER ST. TO SENTNER ST.**

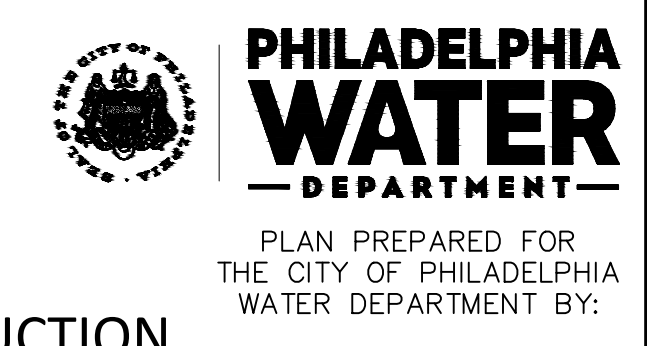

EXAMPLE PLAN 2021 - NOT FOR CONSTRUCTION  
THIS PLAN WAS DEVELOPED TO DEMONSTRATE DRAWING STANDARDS  
AND MAY NOT REFLECT CURRENT DESIGN STANDARDS

**DRAFT SUBSTANTIALLY COMPLETE  
DESIGN SUBMISSION <DATE>**

APPROVED \_\_\_\_\_ CONSULTING ENGINEERING FIRM \_\_\_\_\_

CITY OF PHILADELPHIA  
WATER DEPARTMENT

SCALES:  
PLAN 1"=10'  
PROFILE HORIZ. 1"=10'  
VERT. 1"=5'  
SECTION 1/4"=1'-0"

WORK NO. S-50179-G  
SHEET NO. G-13 OF 67 SHEETS

|               |               |          |
|---------------|---------------|----------|
| DRAWN BY      | CAD           | XXX XXXX |
| PROJECT ENGR. | PROJECT ENGR. | XXX XXXX |

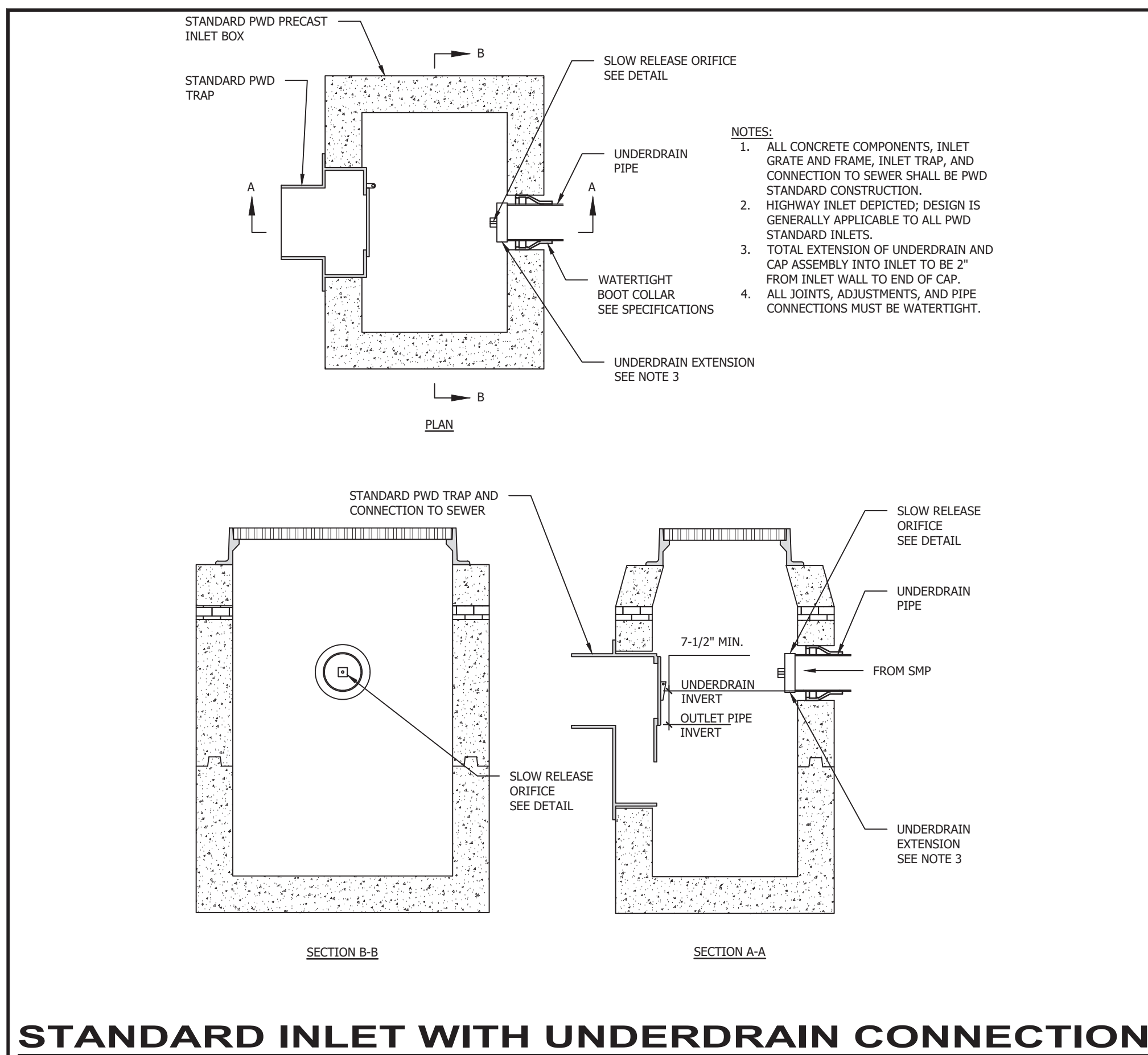

**STANDARD INLET WITH UNDERDRAIN CONNECTION**  
SCALE: N.T.S.

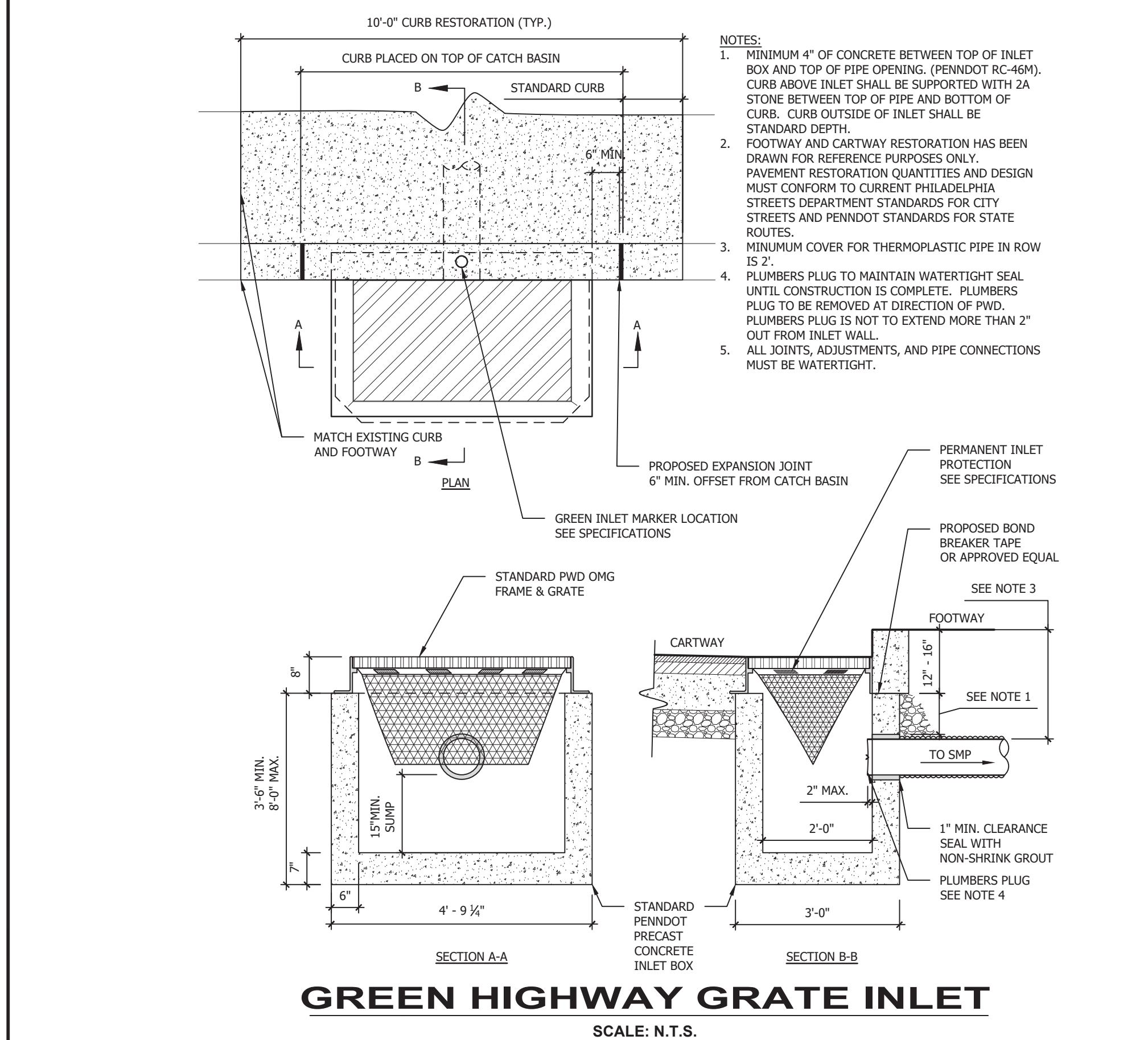

**GREEN HIGHWAY GATE INLET**  
SCALE: N.T.S.

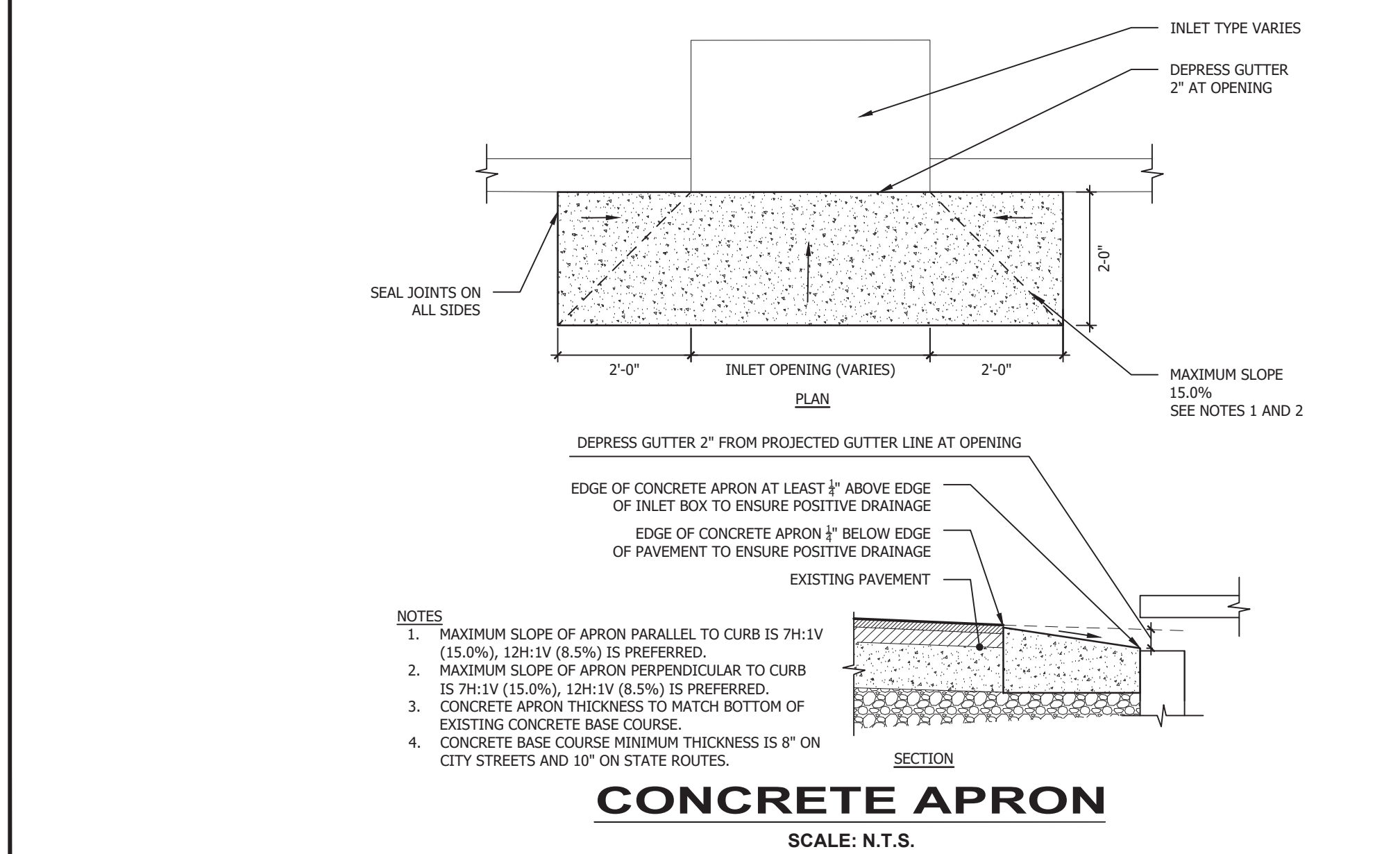

**CONCRETE APRON**  
SCALE: N.T.S.

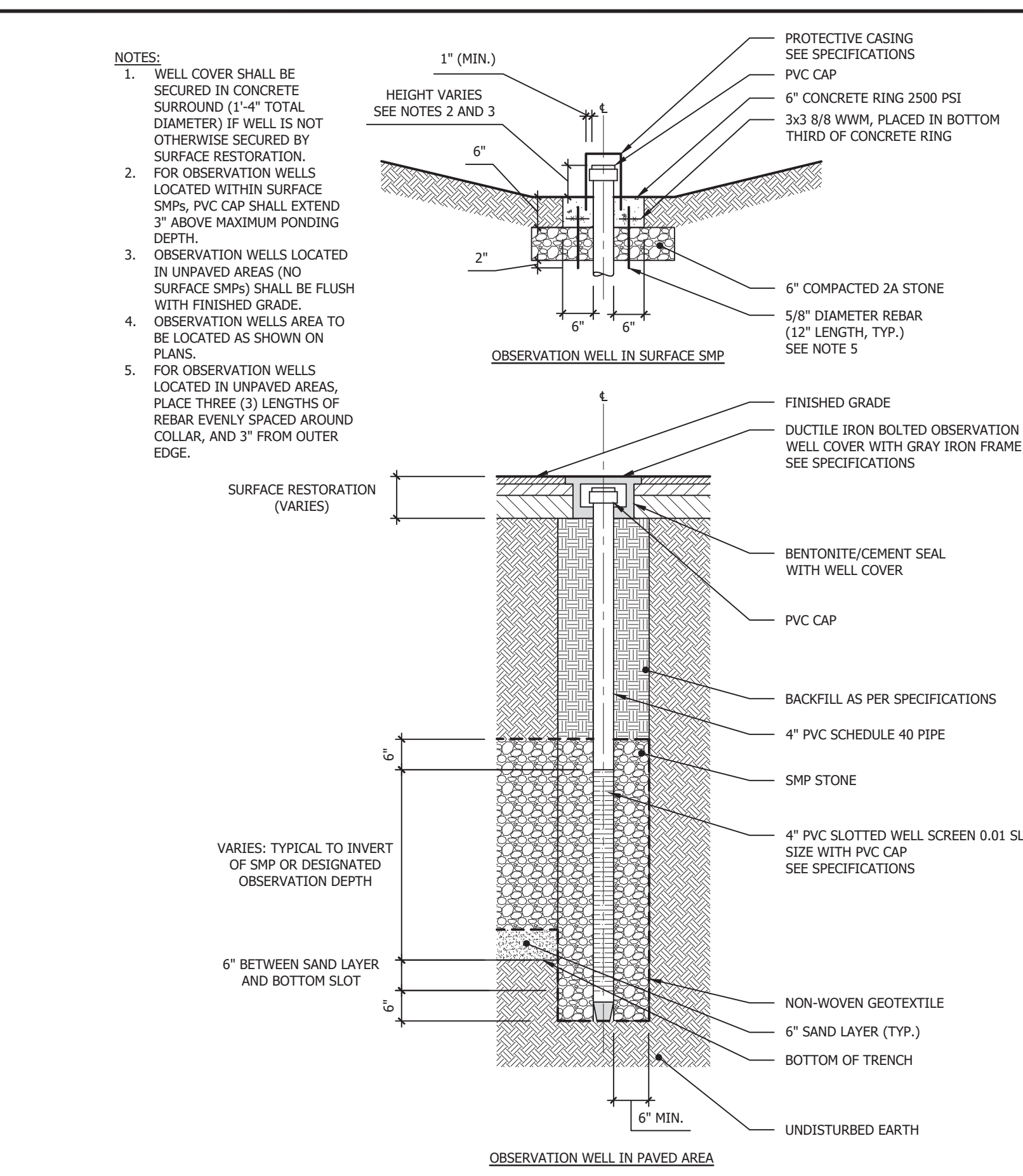

**OBSERVATION WELL IN INFILTRATION TRENCH**  
SCALE: N.T.S.

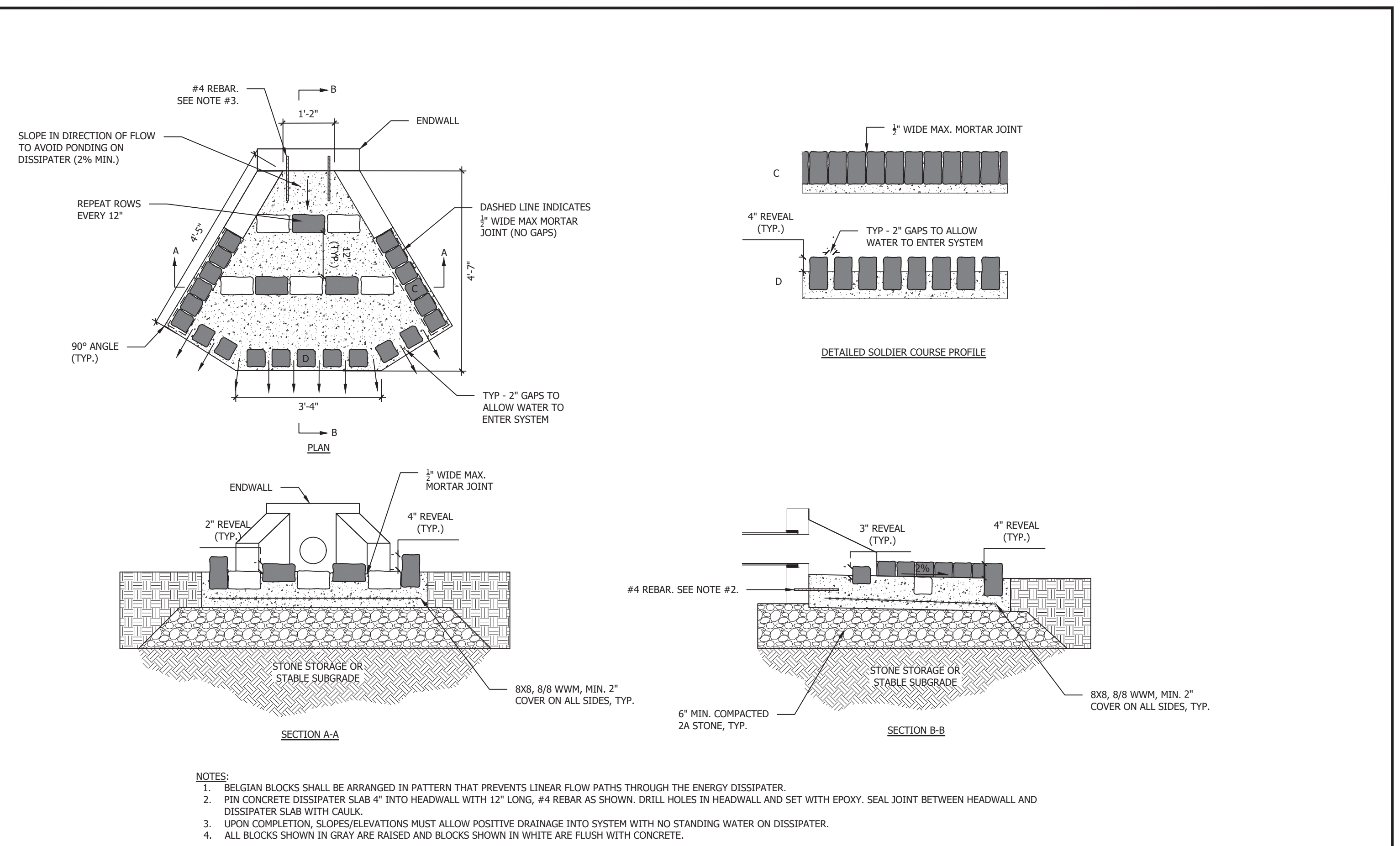

**ENDWALL ENERGY DISSIPATER**  
SCALE: N.T.S.

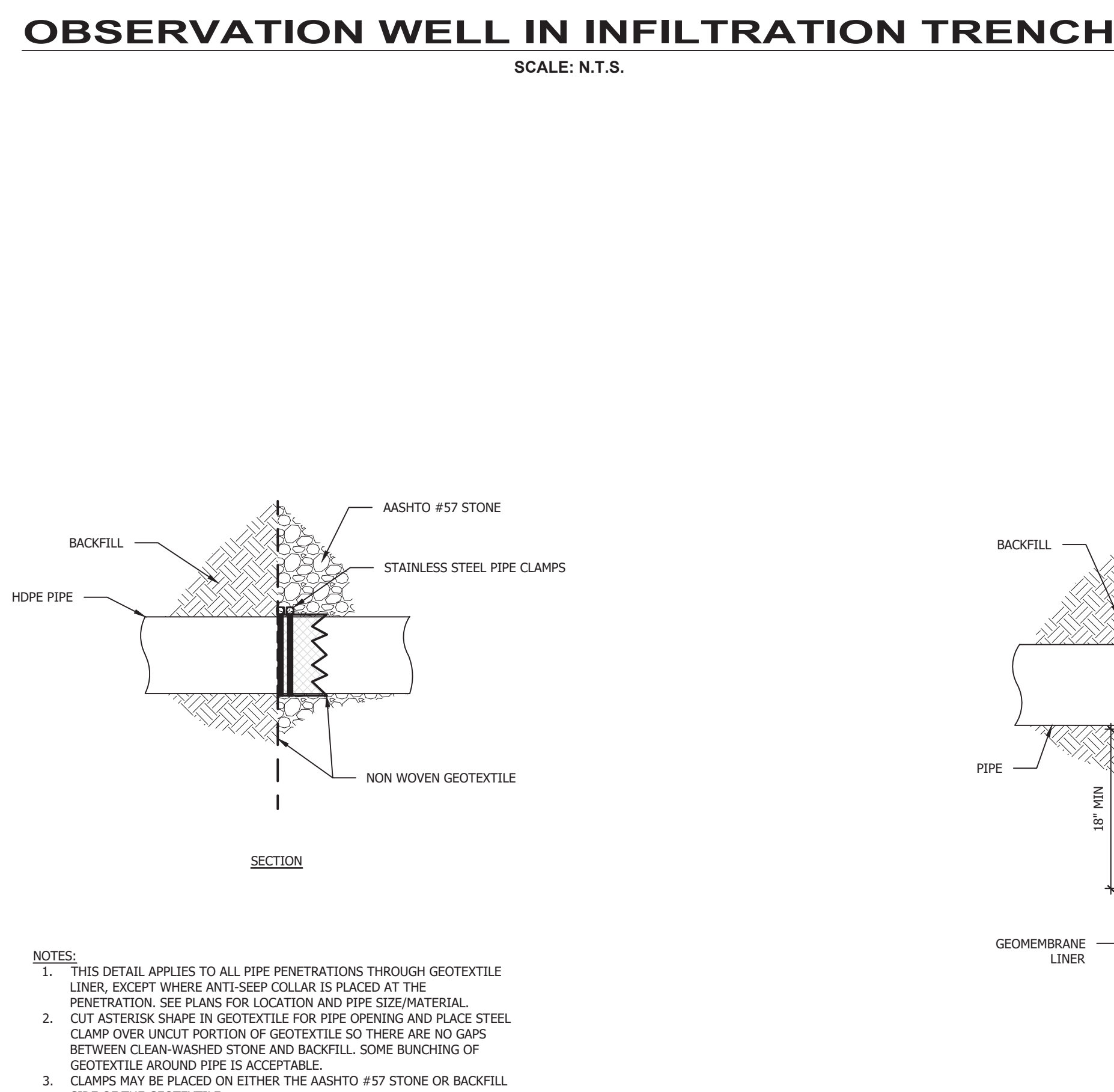

**GEOTEXTILE PIPE PENETRATION**  
SCALE: N.T.S.

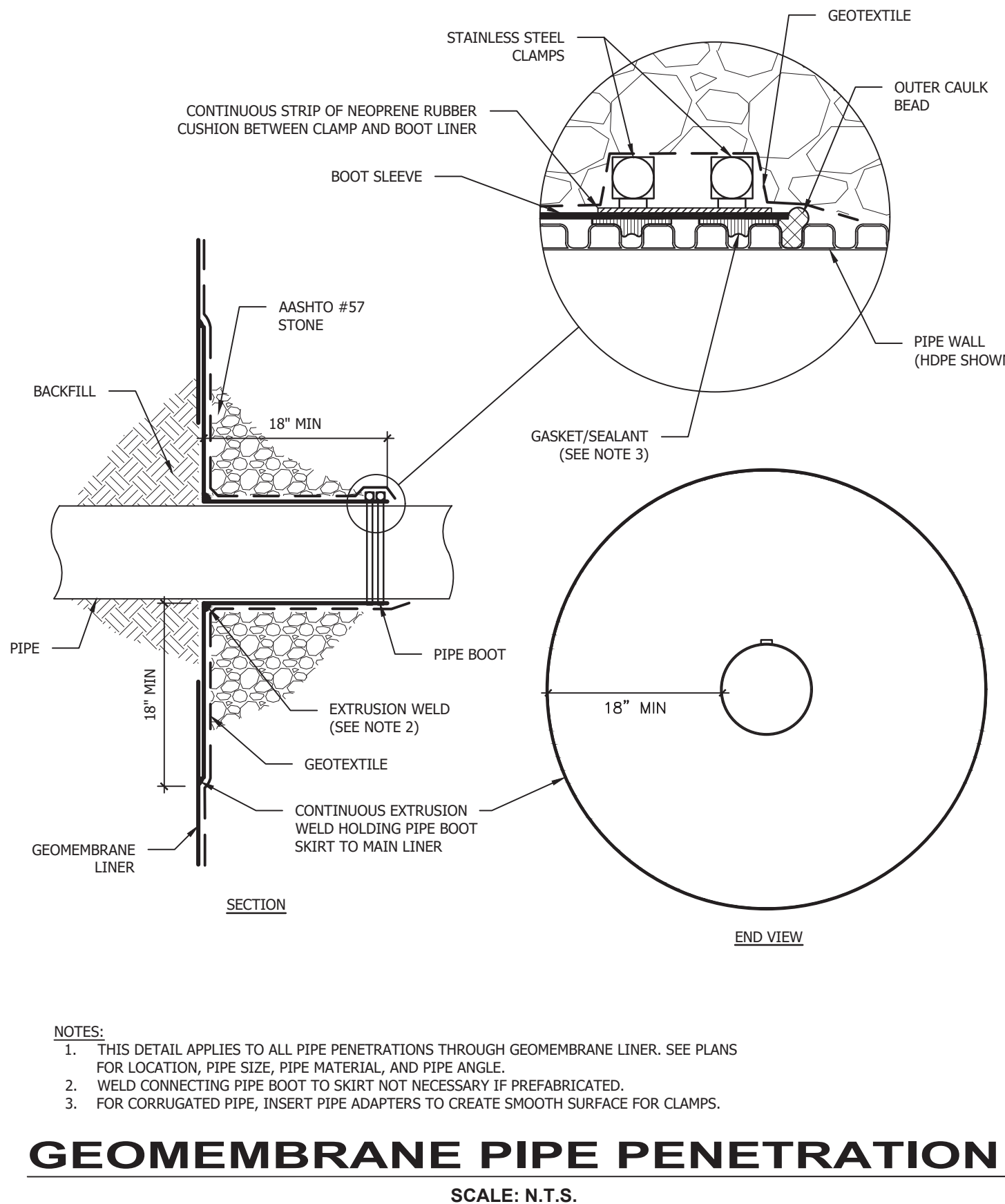

**GEOMEMBRANE PIPE PENETRATION**  
SCALE: N.T.S.

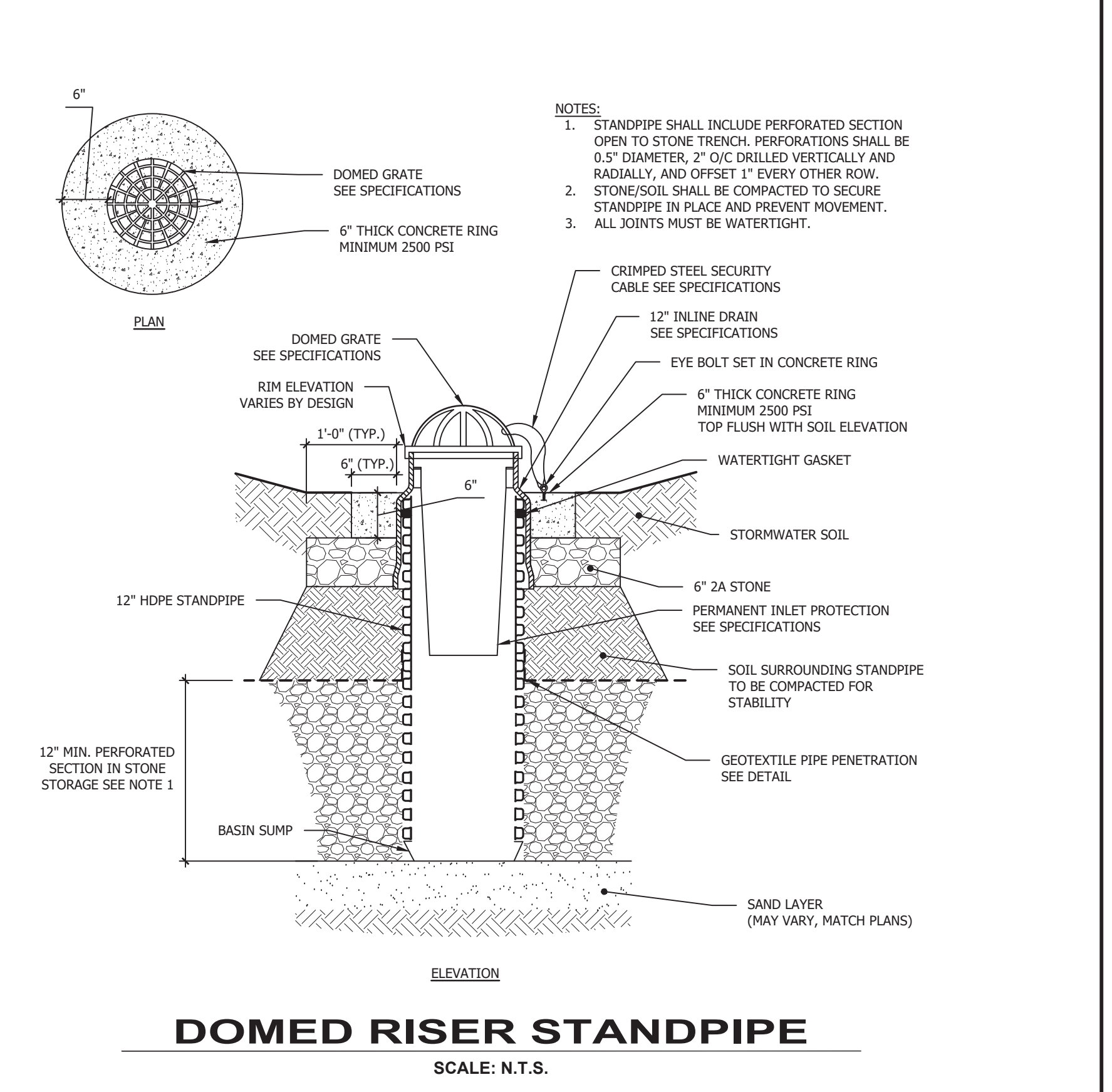

**DOMED RISER STANDPIPE**  
SCALE: N.T.S.

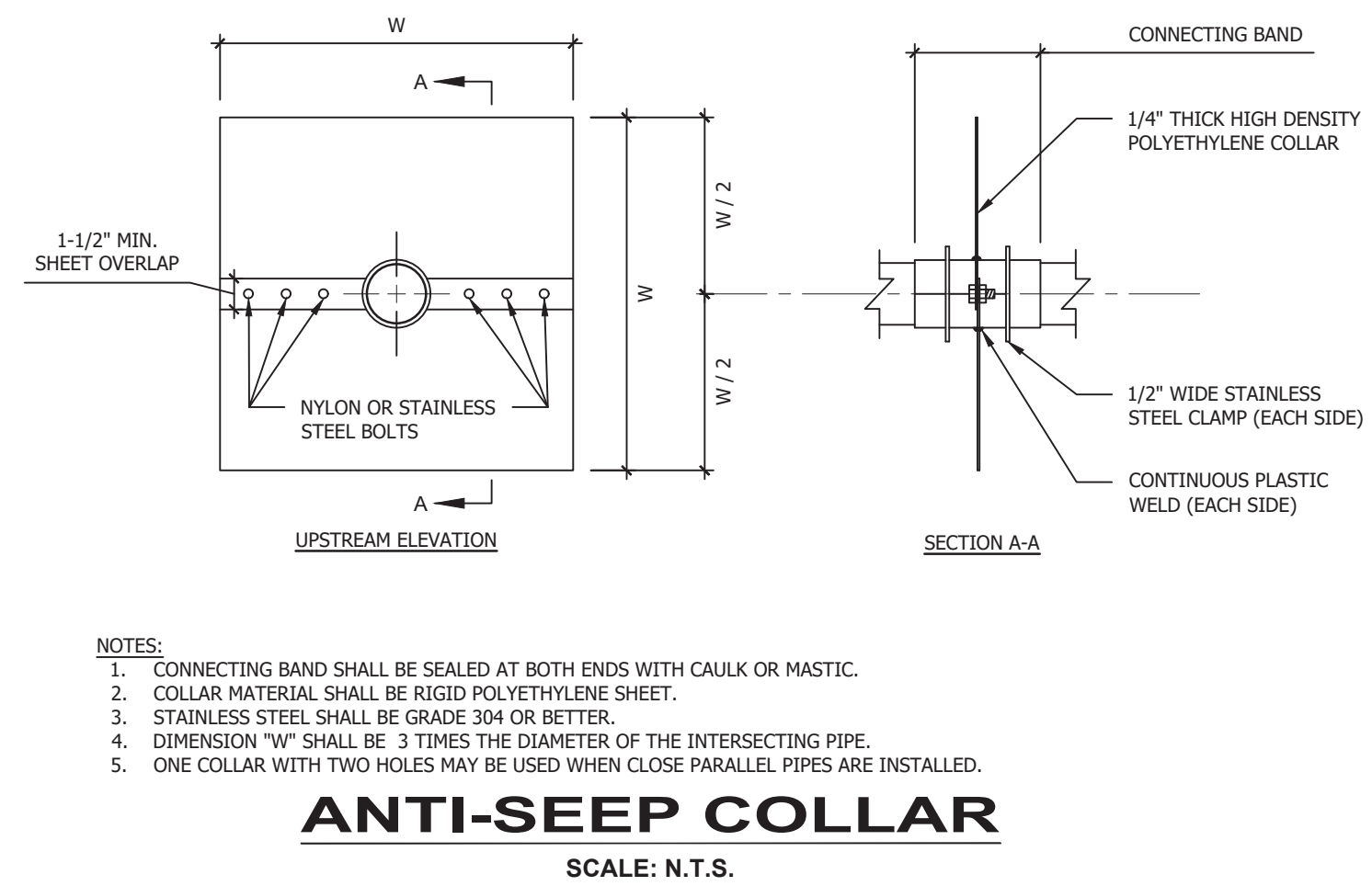

**ANTI-SEEP COLLAR**  
SCALE: N.T.S.

**DESIGNER NOTES:**

- OTHER SITE DETAILS MUST BE ADDED AS APPLICABLE.



**PHILADELPHIA WATER DEPARTMENT**

PLAN PREPARED FOR THE CITY OF PHILADELPHIA WATER DEPARTMENT BY:

EXAMPLE PLAN 2021 - NOT FOR CONSTRUCTION  
THIS PLAN WAS DEVELOPED TO DEMONSTRATE DRAWING STANDARDS  
AND MAY NOT REFLECT CURRENT DESIGN STANDARDS  
**DRAFT SUBSTANTIALLY COMPLETE DESIGN SUBMISSION <DATE>**

**GREEN STORMWATER INFRASTRUCTURE PROJECT**

**BERKS AND SEDGLEY GREENING CONSTRUCTION DETAILS 1**

APPROVED \_\_\_\_\_ CONSULTING ENGINEERING FIRM

CITY OF PHILADELPHIA WATER DEPARTMENT

WORK NO. S-50179-G  
SHEET NO. G-19 OF 22 SHEETS

|               |               |          |
|---------------|---------------|----------|
| DRAWN BY:     | CAD           | XXX XXXX |
| PROJECT ENGR. | PROJECT ENGR. | XXX XXXX |

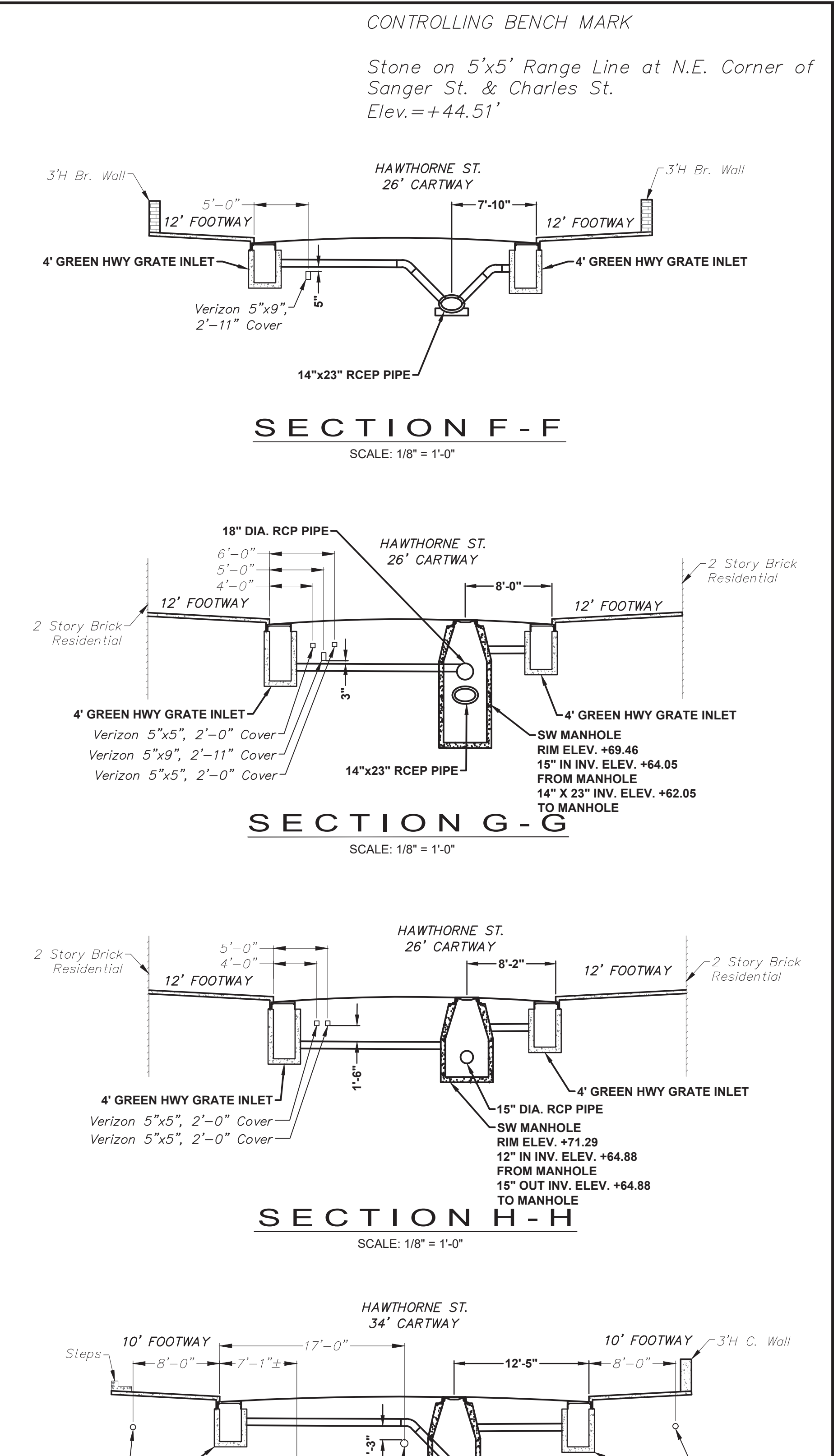
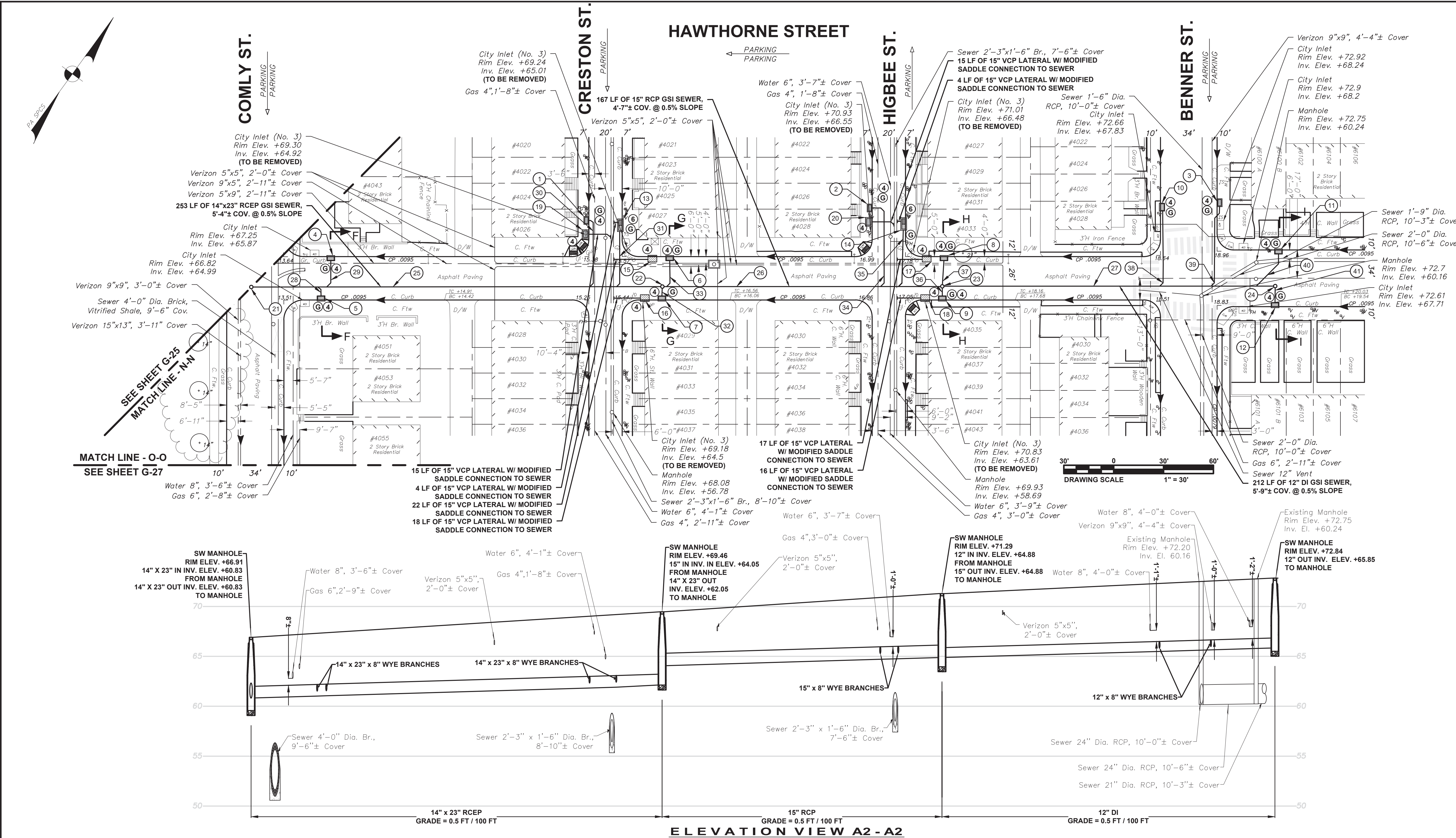

| STRUCTURES |              |  |                 |  |
|------------|--------------|--|-----------------|--|
| #          | COMPONENT ID | COMPONENT TYPE                         | GRATE/RIM ELEV. | OUT INV. ELEV.                           |
| 1          |              | GREEN CITY INLET                       | +69.27          | +66.27                                   |
| 2          |              | GREEN CITY INLET                       | +71.07          | +68.07                                   |
| 3          |              | GREEN CITY INLET                       | +73.20          | +70.20                                   |
| 4          |              | GREEN HWY GRATE INLET                  | +67.06          | +64.56                                   |
| 5          |              | GREEN HWY GRATE INLET                  | +66.71          | +64.21                                   |
| 6          |              | GREEN HWY GRATE INLET                  | +69.60          | +65.60                                   |
| 7          |              | GREEN HWY GRATE INLET                  | +69.48          | +66.98                                   |
| 8          |              | GREEN HWY GRATE INLET                  | +71.68          | 67.68                                    |
| 9          |              | GREEN HWY GRATE INLET                  | +71.22          | +68.72                                   |
| 10         |              | GREEN HWY GRATE INLET                  | +72.90          | +70.40                                   |
| 11         |              | GREEN HWY GRATE INLET                  | +72.76          | +70.26                                   |
| 12         |              | GREEN HWY GRATE INLET                  | +72.83          | +70.33                                   |
| 13         |              | GREEN DUAL CATCH BASIN HWY GRATE INLET | +69.12          | +66.62 (TO GSI SEWER); +64.12 (TO SEWER) |
| 14         |              | GREEN DUAL CATCH BASIN HWY GRATE INLET | +70.74          | +68.24 (TO GSI SEWER); +65.74 (TO SEWER) |
| 15         |              | HWY GRATE INLET                        | +69.56          | +64.56                                   |
| 16         |              | HWY GRATE INLET                        | +69.18          | +64.18                                   |
| 17         |              | HWY GRATE INLET                        | +70.95          | +65.95                                   |
| 18         |              | HWY GRATE INLET                        | +70.83          | +65.83                                   |
| 19         |              | CITY INLET                             | +69.30          | +64.30                                   |
| 20         |              | CITY INLET                             | +71.30          | +66.30                                   |
| 21         |              | SW MANHOLE                             | +66.91          | SEE PLAN FOR ELEVATIONS                  |
| 22         |              | SW MANHOLE                             | +69.46          | SEE PLAN FOR ELEVATIONS                  |
| 23         |              | SW MANHOLE                             | +71.29          | SEE PLAN FOR ELEVATIONS                  |
| 24         |              | SW MANHOLE                             | +72.84          | SEE PLAN FOR ELEVATIONS                  |

| PIPES |              |                   |                     |                  |
|-------|--------------|-------------------|---------------------|------------------|
| #     | COMPONENT ID | COMPONENT TYPE    | PIPE SIZE/DIA. (IN) | PIPE LENGTH (FT) |
| 25    |              | GSI SEWER         | 14" x 23"           | 246              |
| 26    |              | GSI SEWER         | 15"                 | 167              |
| 27    |              | GSI SEWER         | 12"                 | 199              |
| 28    |              | DISTRIBUTION PIPE | 8"                  | 7                |
| 29    |              | DISTRIBUTION PIPE | 8"                  | 17               |
| 30    |              | DISTRIBUTION PIPE | 8"                  | 43               |
| 31    |              | DISTRIBUTION PIPE | 8"                  | 34               |
| 32    |              | DISTRIBUTION PIPE | 8"                  | 5                |
| 33    |              | DISTRIBUTION PIPE | 8"                  | 17               |
| 34    |              | DISTRIBUTION PIPE | 8"                  | 55               |
| 35    |              | DISTRIBUTION PIPE | 8"                  | 38               |
| 36    |              | DISTRIBUTION PIPE | 8"                  | 5                |
| 37    |              | DISTRIBUTION PIPE | 8"                  | 15               |
| 38    |              | DISTRIBUTION PIPE | 8"                  | 47               |
| 39    |              | DISTRIBUTION PIPE | 8"                  | 50               |
| 40    |              | DISTRIBUTION PIPE | 8"                  | 25               |
| 41    |              | DISTRIBUTION PIPE | 8"                  | 9                |

- GENERAL NOTES:
- ALL DISTANCES SHOWN ARE IN DISTRICT STANDARD MEASUREMENT. PAYMENT FOR ALL WORK WILL BE BASED UPON THAT STANDARD.
  - THE LOCATIONS AND ELEVATIONS OF THE EXISTING UTILITIES ARE APPROXIMATE. THE ELEVATIONS OF THE EXISTING UTILITIES MUST BE FIELD CHECKED DURING CONSTRUCTION.
  - ALL SIDEWALK AND CURBING TO BE REPLACED IN KIND ALONG FULL LIMITS OF CONSTRUCTION TO NEXT EXISTING JOINT OR AS DIRECTED BY PWD.
  - WELDED PIPE BOOT SEAL MUST BE INSTALLED AT ANY POINT WHERE A PIPE PENETRATES GEOMEMBRANE LINER.
  - SUFFICIENT EROSION AND SEDIMENTATION CONTROL MEASURES WILL BE INSTALLED AND MAINTAINED BY THE CONTRACTOR AS TO PREVENT STANDING WATER OR SEDIMENTATION OF STORMWATER SYSTEMS. SYSTEMS DETERMINED BY PWD TO BE INADEQUATELY PROTECTED AND THEREBY COMPROMISED WILL BE REPLACED TO THE EXTENT REQUIRED BY PWD (UP TO AND INCLUDING FULL REPLACEMENT) AT NO ADDITIONAL COST TO PWD.
  - ORIFICE SHOULD NOT BE DRILLED PRIOR TO AUTHORIZATION BY PWD. PWD WILL REVIEW THE RESULTS OF THE DOUBLE RING INFILTRATOR TESTS CONDUCTED AFTER SMP EXCAVATION AND WILL CONFIRM ORIFICE DIMENSIONS.
  - EROSION CONTROL MATTING SHALL BE PLACED OVER ALL SOIL SURFACES NOT STABILIZED BY PLANTING.
  - SUPPORT AND PROTECT ALL UTILITIES, UTILITY POLES, OVERHEAD WIRES, TRAFFIC SIGNAGE, TRAFFIC SIGNALS, AND STREET LIGHTING WITHIN THE LIMITS OF WORK.
  - VERTICAL DATUM IS ON CITY OF PHILADELPHIA DATUM.
  - LINE AND GRADE STAKES FOR CURB, PAVING, ETC. WILL BE FURNISHED BY THE 5TH SURVEY DISTRICT OF THE CITY OF PHILADELPHIA. CONTACT INFORMATION: 5TH SURVEY DISTRICT, 6601 RISING SUN AVE., PHILA., PA, 19111, (215) 685-0585.
  - NOTIFY THE 5TH SURVEY DISTRICT A MINIMUM OF TWO (2) WEEKS PRIOR TO THE START OF WORK TO SCHEDULE A TIME FOR CURB STAKE LAYOUT SERVICES.

NOTE: PIPES CONNECTING GREEN INLETS TO GSI SEWER MAIN ARE DUCTILE IRON PIPE UNLESS INDICATED OTHERWISE.

NOTICE:  
PURSUANT TO THE REQUIREMENTS OF PENNSYLVANIA ACT 50 (2017), THE CONTRACTOR SHALL CONTACT THE PENNSYLVANIA ONE CALL SYSTEM AT 1-800-242-1776, AT LEAST 3 DAYS PRIOR TO EXCAVATION.

HIGHWAY DISTRICT NO. 05 WARD NUMBER 82  
SURVEY DISTRICT NO. 05 DRAINAGE SHT. NO. 72  
OUTFALL NO. F21 PA ONE CALL

20160200723  
20160200724  
20160693294  
20160693295  
20160693411

**GREEN STORMWATER INFRASTRUCTURE PROJECT**

**WISSINOMING PARK  
GSI SEWER TO SMP 1267-01-01  
HAWTHORNE STREET  
COMLY ST. TO BENNER ST.**

APPROVED \_\_\_\_\_ CONSULTING ENGINEERING FIRM \_\_\_\_\_

CITY OF PHILADELPHIA WATER DEPARTMENT

PLAN PREPARED FOR THE CITY OF PHILADELPHIA WATER DEPARTMENT BY:

SCALE: PLAN 1"=30'  
PROFILE 1"=30'  
VERT. 1"=5'  
SECTION 1/8"=1'-0"

WORK NO. S-50179-G  
SHEET NO. G-26 OF XX SHEETS

DRAWN BY: CAD PROJECT ENGR. XXX XXXX

EXAMPLE PLAN 2021 - NOT FOR CONSTRUCTION  
THIS PLAN WAS DEVELOPED TO DEMONSTRATE DRAWING STANDARDS  
AND MAY NOT REFLECT CURRENT DESIGN STANDARDS

**DRAFT SUBSTANTIALLY COMPLETE  
DESIGN SUBMISSION <DATE>**



**PHILADELPHIA  
WATER  
DEPARTMENT**

INSERT COMPANY LOGO AND ADDRESS HERE

CONTROLLING BENCH MARK

MAG NAIL IN U.P. #J3144 LOCATED ON THE N.E. CORNER OF W. BERKS ST. AND UPLAND WAY ELEV. = 191.00

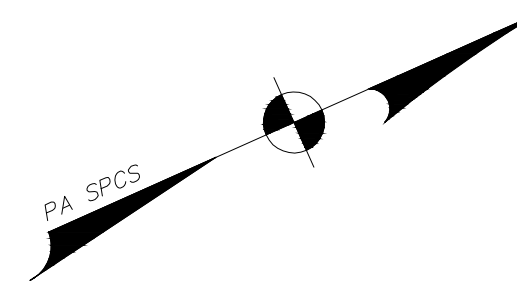

### N. 59TH STREET

### UPLAND WAY

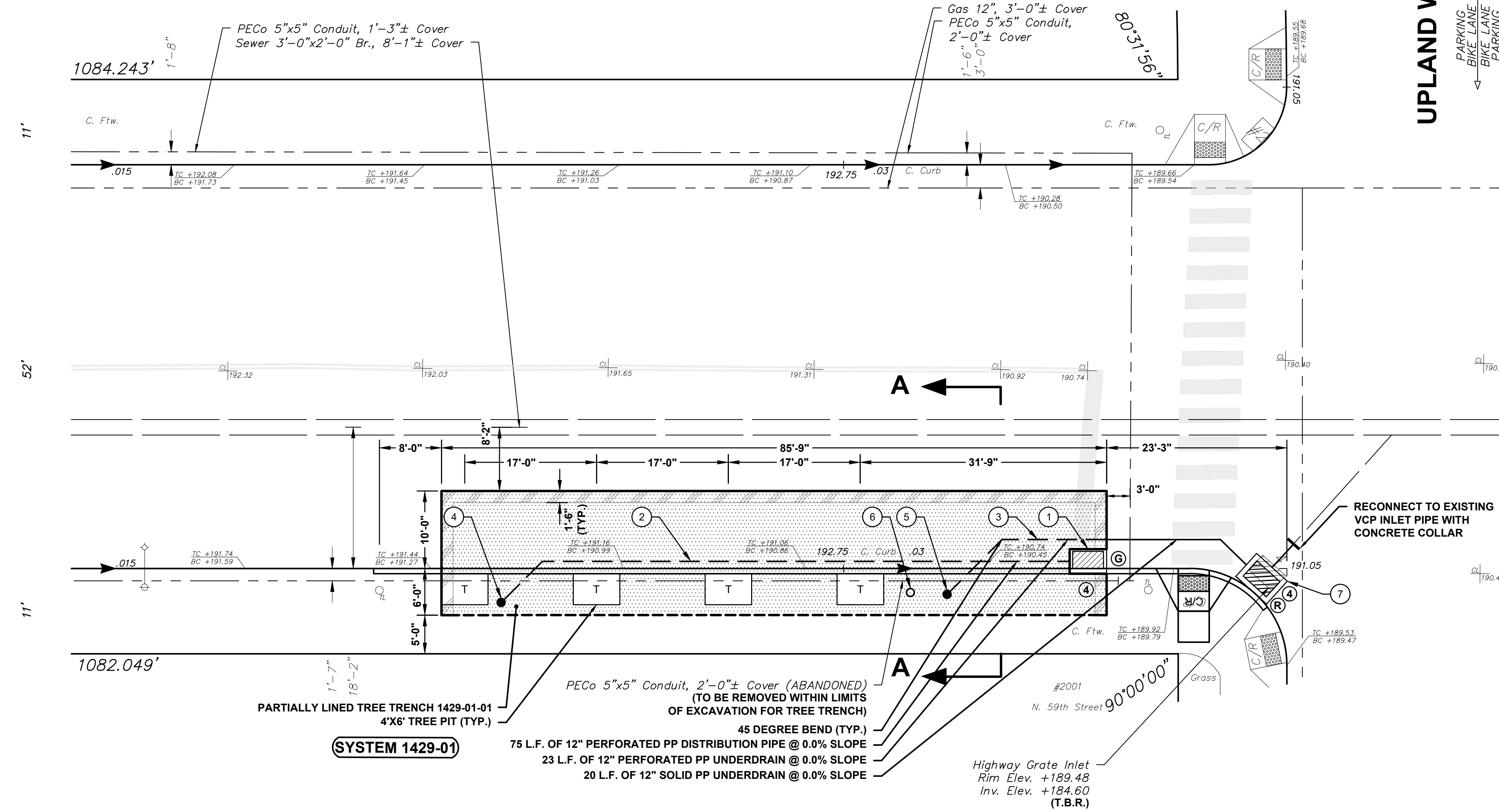

| # | COMPONENT ID    | COMPONENT TYPE        | PIPE LENGTH (FT) |
|---|-----------------|-----------------------|------------------|
| 1 | G14290101-14-05 | GREEN HWY GRATE INLET | N/A              |
| 2 | G14290101-20-05 | DISTRIBUTION PIPE     | 75               |
| 3 | G14290101-21-05 | UNDERDRAIN            | 43               |
| 4 | G14290101-50-05 | CLEANOUT              | N/A              |
| 5 | G14290101-50-10 | CLEANOUT              | N/A              |
| 6 | G14290101-51-05 | OBSERVATION WELL      | N/A              |
| 7 | G14290101-60-05 | HWY GRATE INLET       | N/A              |

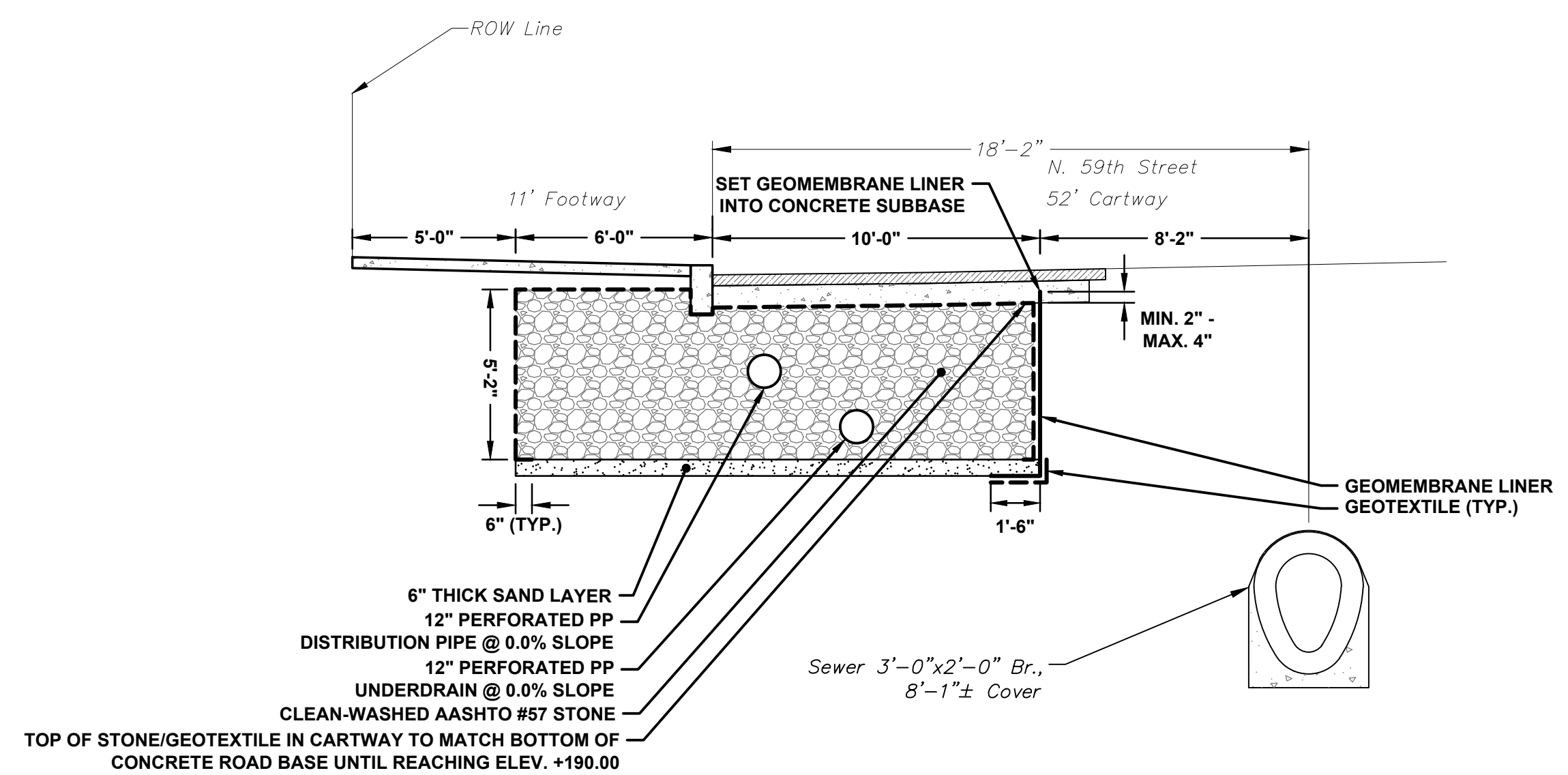

**SECTION A-A**  
SCALE: 1/4" = 1'-0"

#### PROPOSED LEGEND

|  |   |  |  |
|--|---|--|--|
|  | SOLID PIPE                                |  | CLEANOUT                                 |
|  | PERFORATED PIPE                           |  | OBSERVATION WELL                         |
|  | ANTI-SLEEP COLLAR                         |  | GREEN HIGHWAY GRATE INLET                |
|  | STORMWATER TRENCH W/ GEOTEXTILE ON SIDES  |  | HIGHWAY GRATE INLET                      |
|  | STORMWATER TRENCH W/ GEOMEMBRANE ON SIDES |  | DENOTES PROPOSED GREEN INLET             |
|  | GEOMEMBRANE LINER                         |  | DENOTES PROPOSED INLET TO BE RECONNECTED |
|  | TREE PIT                                  |  | DENOTES 4" INLET                         |
|  |   |  | TO BE REMOVED                            |

#### NOTICE:

PURSUANT TO THE REQUIREMENTS OF PENNSYLVANIA ACT 50 (2017), THE CONTRACTOR SHALL CONTACT THE PENNSYLVANIA ONE CALL SYSTEM AT 1-800-242-1776, AT LEAST 3 DAYS PRIOR TO EXCAVATION.

HIGHWAY DISTRICT NO. 01 WARD NUMBER 34/52  
 SURVEY DISTRICT NO. 07 DRAINAGE SHT. NO. 33  
 OUTFALL NO. S-27/S-50 PA ONE CALL 20181993459  
 20181993460

#### GREEN STORMWATER INFRASTRUCTURE PROJECT

### UPLAND WAY GREENING GRADING & UTILITY PLAN – SYSTEM 1429-01 N. 59TH STREET LANCASTER AVE. TO UPLAND WAY



PLAN PREPARED FOR THE CITY OF PHILADELPHIA WATER DEPARTMENT BY:

APPROVED \_\_\_\_\_ CONSULTING ENGINEERING FIRM \_\_\_\_\_  
 CITY OF PHILADELPHIA WATER DEPARTMENT  
 SCALES:  
 PLAN 1"=10'  
 PROFILE HORIZ. 1"=10'  
 VERT. 1"=5'  
 SECTION 1/4"=1'

EXAMPLE PLAN 2021 - NOT FOR CONSTRUCTION  
 THIS PLAN WAS DEVELOPED TO DEMONSTRATE DRAWING STANDARDS  
 AND MAY NOT REFLECT CURRENT DESIGN STANDARDS  
**DRAFT PRE-FINAL DESIGN**  
**SUBMISSION <DATE>**

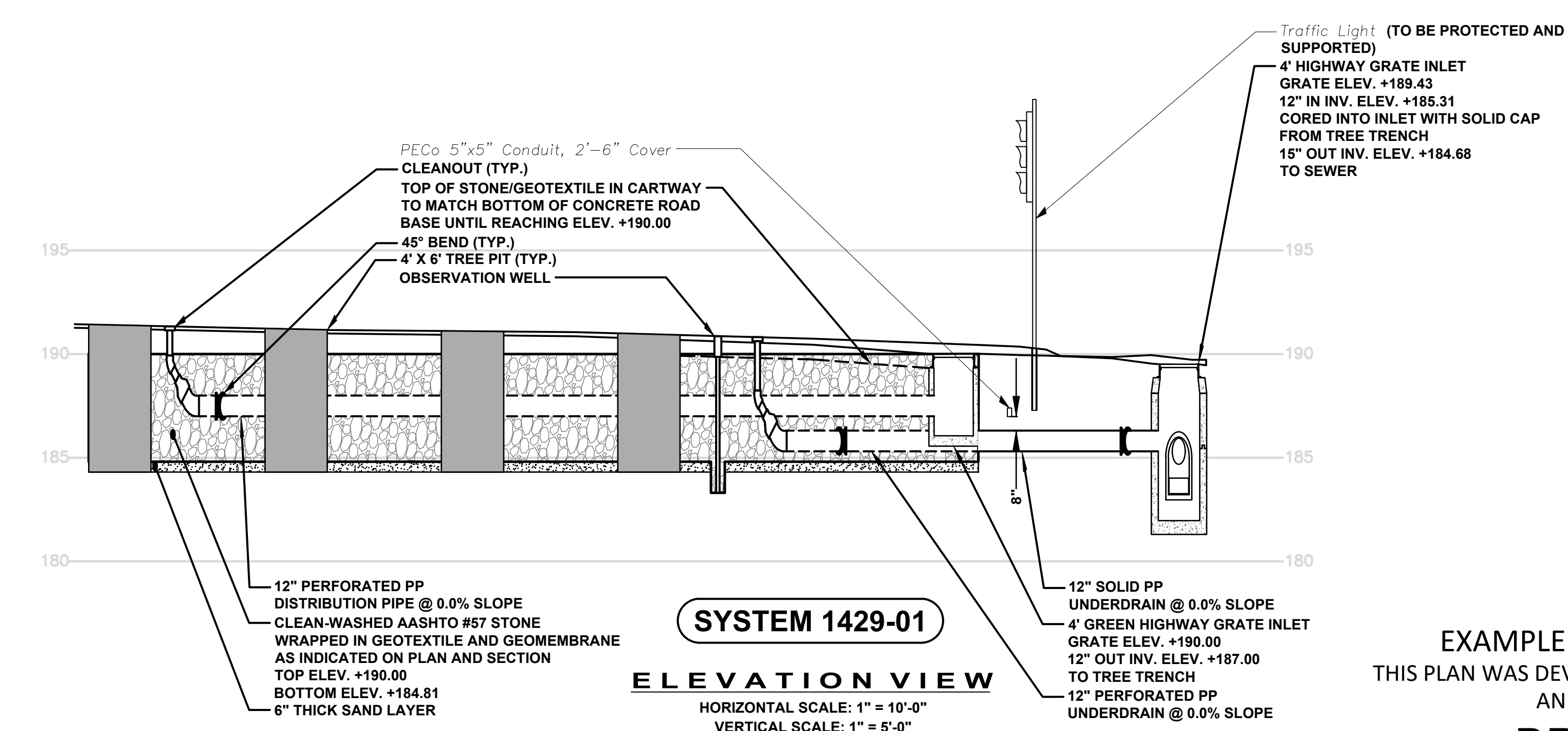

**SYSTEM 1429-01**  
ELEVATION VIEW  
HORIZONTAL SCALE: 1" = 10'-0"  
VERTICAL SCALE: 1/4" = 5'-0"

- NOTE:  
OVERHEAD WIRES ON EAST SIDE OF N. 59TH STREET.
- GENERAL NOTES:
- ALL DISTANCES SHOWN ARE IN DISTRICT STANDARD MEASUREMENT. PAYMENT FOR ALL WORK WILL BE BASED UPON THAT STANDARD.
  - THE LOCATIONS AND ELEVATIONS OF THE EXISTING UTILITIES ARE APPROXIMATE. THE ELEVATIONS OF THE EXISTING UTILITIES MUST BE FIELD CHECKED DURING CONSTRUCTION.
  - ALL SIDEWALK AND CURBING TO BE REPLACED IN KIND ALONG FULL LIMITS OF CONSTRUCTION TO NEXT EXISTING JOINT OR AS DIRECTED BY PWD.
  - WELDED PIPE BOOT SEAL MUST BE INSTALLED AT ANY POINT WHERE A PIPE PENETRATES GEOMEMBRANE LINER.
  - SUFFICIENT EROSION AND SEDIMENTATION CONTROL MEASURES WILL BE INSTALLED AND MAINTAINED BY THE CONTRACTOR AS TO PREVENT STANDING WATER OR SEDIMENTATION OF STORMWATER SYSTEMS. SYSTEMS DETERMINED BY PWD TO BE INADEQUATELY PROTECTED AND THEREBY COMPROMISED WILL BE REPLACED TO THE EXTENT REQUIRED BY PWD (UP TO AND INCLUDING FULL REPLACEMENT) AT NO ADDITIONAL COST TO PWD.
  - ORIFICE SHOULD NOT BE DRILLED PRIOR TO AUTHORIZATION BY PWD. PWD WILL REVIEW THE RESULTS OF THE DOUBLE RING INFILTRATOR TESTS CONDUCTED AFTER SMP EXCAVATION AND WILL CONFIRM ORIFICE DIMENSIONS.
  - EROSION CONTROL MATTING SHALL BE PLACED OVER ALL SOIL SURFACES NOT STABILIZED BY PLANTING.
  - SUPPORT AND PROTECT ALL UTILITIES, UTILITY POLES, OVERHEAD WIRES, TRAFFIC SIGNAGE, TRAFFIC SIGNALS, AND STREET LIGHTING WITHIN THE LIMITS OF WORK.
  - VERTICAL DATUM IS ON CITY OF PHILADELPHIA DATUM.
  - LINE AND GRADE STAKES FOR CURB, PAVING, ETC. WILL BE FURNISHED BY THE 7TH SURVEY DISTRICT OF THE CITY OF PHILADELPHIA. CONTACT INFORMATION: 7TH SURVEY DISTRICT, 6448 WOODLAND AVE, PHILA., PA. 19142, (215) 685-3052.
  - NOTIFY THE 7TH SURVEY DISTRICT A MINIMUM OF TWO (2) WEEKS PRIOR TO THE START OF WORK TO SCHEDULE A TIME FOR CURB STAKE LAYOUT SERVICES.

|              |              |          |
|--------------|--------------|----------|
| DRAWN BY     | CAD          | XXX XXXX |
| PROJECT ENGR | PROJECT ENGR | XXX XXXX |
| SUPERVISOR   | DATE         |          |

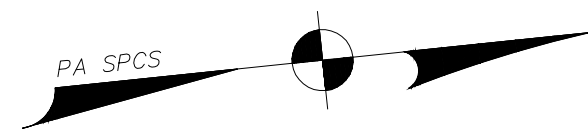

N. 30TH STREET

SYSTEM 1288-05

W. BERKS ST.

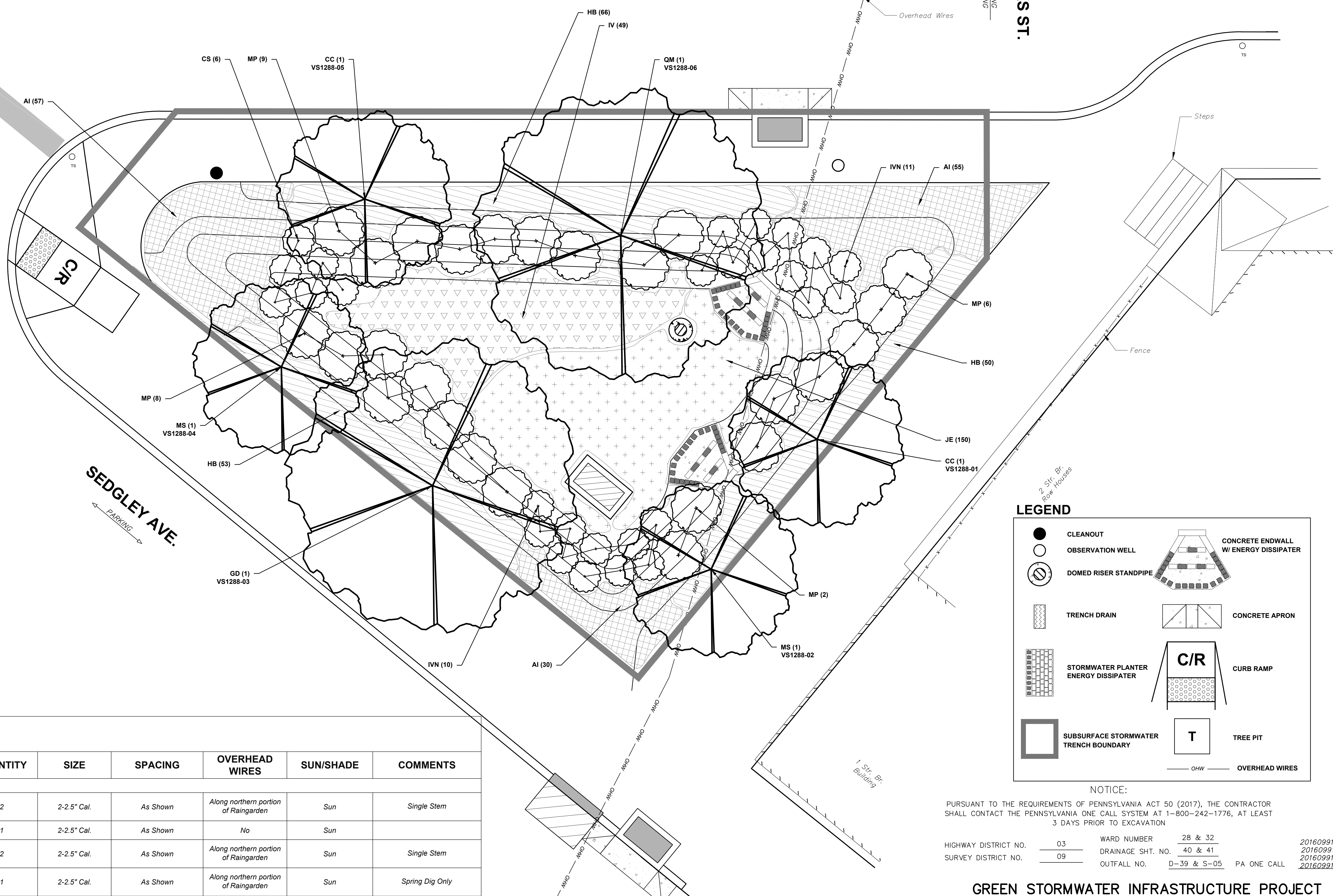

LANDSCAPE NOTES:

- ADJUST LOCATIONS OF PLANTS AS NECESSARY TO AVOID DAMAGE TO EXISTING UNDERGROUND UTILITIES AND EXISTING ABOVE GROUND ELEMENTS. ADJUSTMENTS SHALL BE COMPLETED AT CONTRACTOR'S EXPENSE AND SHALL BE COORDINATED WITH THE PHILADELPHIA WATER DEPARTMENT (PWD).
- LANDSCAPE SUBCONTRACTOR SHALL COORDINATE WORK WITH THE GENERAL CONTRACTOR AND ALL OTHER TRADES.
- LANDSCAPE INSTALLATION SHALL BE COORDINATED WITH OTHER WORK AT THIS LOCATION.
- THE CONTRACTOR SHALL PAY FOR AND SUBMIT RESULTS OF ALL TESTING OF SOILS, AMENDMENTS, ETC. ASSOCIATED WITH THE WORK IN ACCORDANCE WITH THE CONTRACT SPECIFICATIONS PRIOR TO THE COMMENCEMENT OF PLANTING.
- PLANT SIZES IN THE PLANT SCHEDULE ARE TO BE CONSIDERED MINIMUM SIZES.
- THE PLANT SCHEDULE IDENTIFIES PLANT SPECIES AND QUANTITIES FOR EACH LOCATION. APPROXIMATE SPACING IS AS SHOWN ON THE PLANTING PLANS.
- IF REQUESTED BY PWD, THE CONTRACTOR SHALL ENSURE PLANTS ARE TAGGED FOR REVIEW AND APPROVAL BY PWD PRIOR TO ORDERING. APPROVAL OF PLANTS AT OFF-SITE LOCATIONS DOES NOT IMPLY FINAL APPROVAL OF PLANTS AT TIME OF DELIVERY OR AT THE TIME OF INSTALLATION.
- THE CONTRACTOR SHALL BE RESPONSIBLE FOR FURNISHING WATER AND HAND WATERING OF PLANTS AFTER INSTALLATION AND UP TO FINAL COMPLETION OF THE PROJECT, AND FOR THE MAINTENANCE PERIOD (SEE SPECIFICATIONS).
- RESEED ALL DISTURBED AREAS.

LEGEND

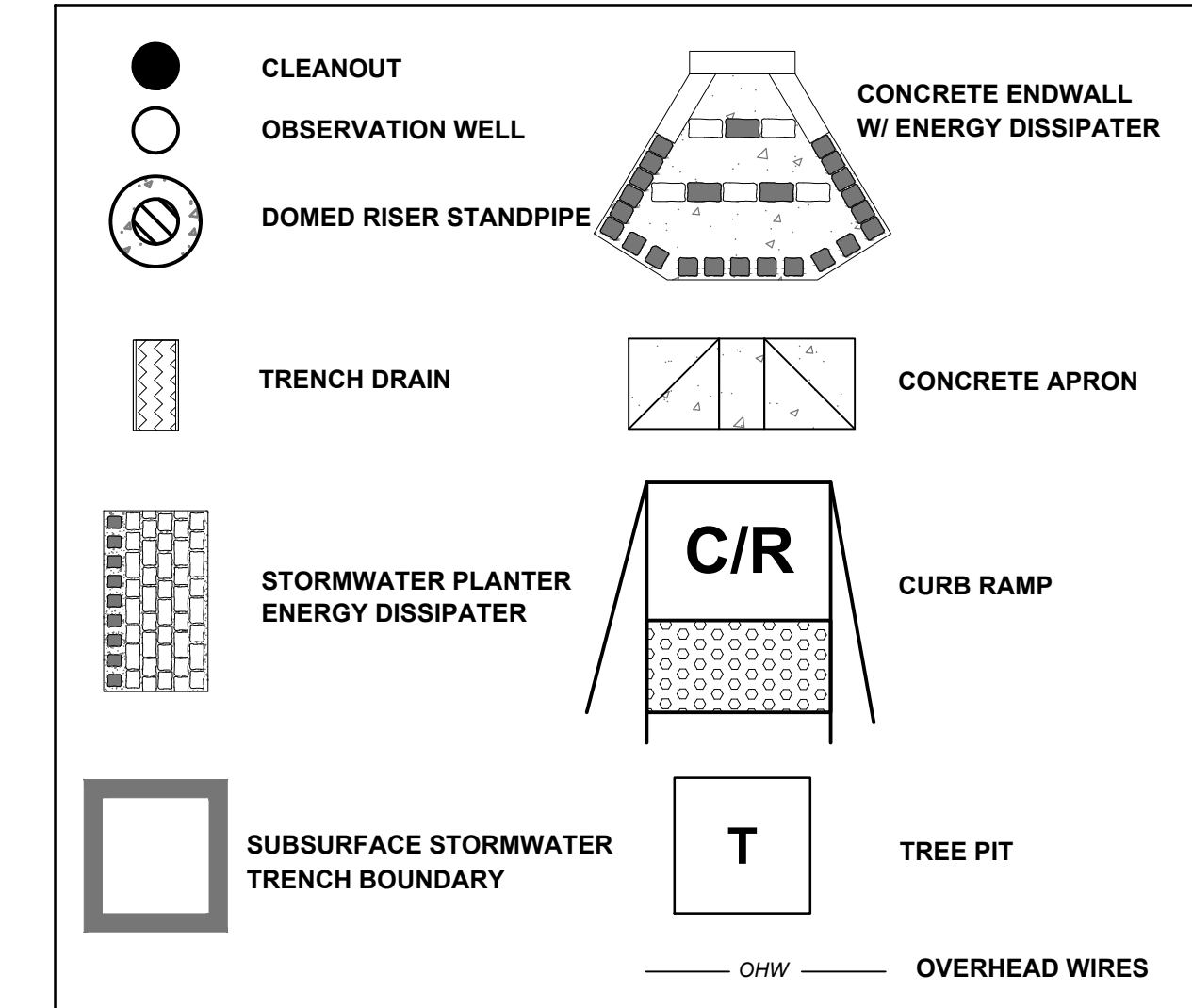

NOTICE:

PURSUANT TO THE REQUIREMENTS OF PENNSYLVANIA ACT 50 (2017), THE CONTRACTOR SHALL CONTACT THE PENNSYLVANIA ONE CALL SYSTEM AT 1-800-242-1776, AT LEAST 3 DAYS PRIOR TO EXCAVATION.

HIGHWAY DISTRICT NO. 03 WARD NUMBER 28 & 32  
 SURVEY DISTRICT NO. 09 DRAINAGE SHT. NO. 40 & 41  
 OUTFALL NO. D-39 & S-05 PA ONE CALL

20160991626  
 20160991611  
 20160991608  
 20160991580

PLANT SCHEDULE

| HATCH PATTERN     | KEY | COMMON NAME                      | BOTANICAL NAME                              | QUANTITY | SIZE        | SPACING  | OVERHEAD WIRES                       | SUN/SHADE | COMMENTS  |
|-------------------|-----|----------------------------------|---|----------|-------------|----------|--------------------------------------|-----------|---|
| <b>TREES</b>      |     |                                  |   |          |             |          |                                      |           |   |
|                   | CC  | Eastern Redbud                   | <i>Cercis canadensis</i>                    | 2        | 2-2.5' Cal. | As Shown | Along northern portion of Raingarden | Sun       | Single Stem   |
|                   | GD  | Kentucky Coffee Tree             | <i>Gymnocladus dioica</i>                   | 1        | 2-2.5' Cal. | As Shown | No                                   | Sun       |   |
|                   | MS  | Prairie Fire Flowering Crabapple | <i>Malus spp. 'Prairie Fire'</i>            | 2        | 2-2.5' Cal. | As Shown | Along northern portion of Raingarden | Sun       | Single Stem   |
|                   | QM  | Chinkapin Oak                    | <i>Quercus muehlenbergii</i>                | 1        | 2-2.5' Cal. | As Shown | Along northern portion of Raingarden | Sun       | Spring Dig Only   |
| <b>SHRUBS</b>     |     |                                  |   |          |             |          |                                      |           |   |
|                   | CS  | Kelseyl Red Twig Dogwood         | <i>Cornus sericea 'Kelseyl'</i>             | 6        | #3 Cont.    | As Shown | N/A                                  | Varies    | Min 18" Height  |
|                   | MP  | Bayberry                         | <i>Myrica pensylvanica</i>                  | 25       | #3 Cont.    | As Shown | N/A                                  | Varies    | Min 18" Height  |
|                   | IVN | Red Sprite Winterberry           | <i>Ilex verticillata 'Nana' RED SPRITE'</i> | 21       | #3 Cont.    | As Shown | N/A                                  | Varies    | Substitute 1 male pollinator per Approx. 10 female plants, such as <i>Ilex verticillata 'Jim Dandy'</i> |
| <b>HERBACEOUS</b> |     |                                  |   |          |             |          |                                      |           |   |
|                   | HB  | Bella Lugosi Daylily             | <i>Hemerocallis 'Bella Lugosi'</i>          | 169      | #1 Cont.    | 18" O.C. | N/A                                  | Varies    |   |
|                   | IV  | Blue Flag Iris                   | <i>Iris versicolor</i>                      | 49       | #1 Cont.    | 18" O.C. | N/A                                  | Varies    |   |
|                   | AI  | Blue Ice Bluestar                | <i>Amsonia 'Blue Ice'</i>                   | 142      | #1 Cont.    | 18" O.C. | N/A                                  | Varies    |   |
| <b>GRASSES</b>    |     |                                  |   |          |             |          |                                      |           |   |
|                   | JE  | Common Rush                      | <i>Juncus effusus</i>                       | 150      | #1 Cont.    | 18" O.C. | N/A                                  | Varies    |   |



PLAN PREPARED FOR THE CITY OF PHILADELPHIA WATER DEPARTMENT BY:

EXAMPLE PLAN 2021 - NOT FOR CONSTRUCTION  
 THIS PLAN WAS DEVELOPED TO DEMONSTRATE DRAWING STANDARDS AND MAY NOT REFLECT CURRENT DESIGN STANDARDS  
**DRAFT SUBSTANTIALLY COMPLETE DESIGN SUBMISSION <DATE>**

GREEN STORMWATER INFRASTRUCTURE PROJECT

BERKS & SEDGLEY GREENING LANDSCAPE PLAN SYSTEM 1288-05

APPROVED \_\_\_\_\_ CONSULTING ENGINEERING FIRM

CITY OF PHILADELPHIA WATER DEPARTMENT

PLAN 1/4" = 1'

WORK NO. S-50179-G  
 SHEET NO. L-3 OF X SHEETS

|               |          |
|---------------|----------|
| DRAWN BY: CAD | XXX XXXX |
| PROJECT ENGR. | XXX XXXX |
| SUPERVISOR    | DATE     |

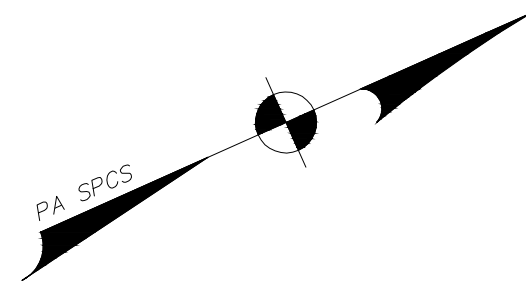

**N. 59TH STREET**

BIKE LANE  
BIKE LANE

**PROPOSED LEGEND**

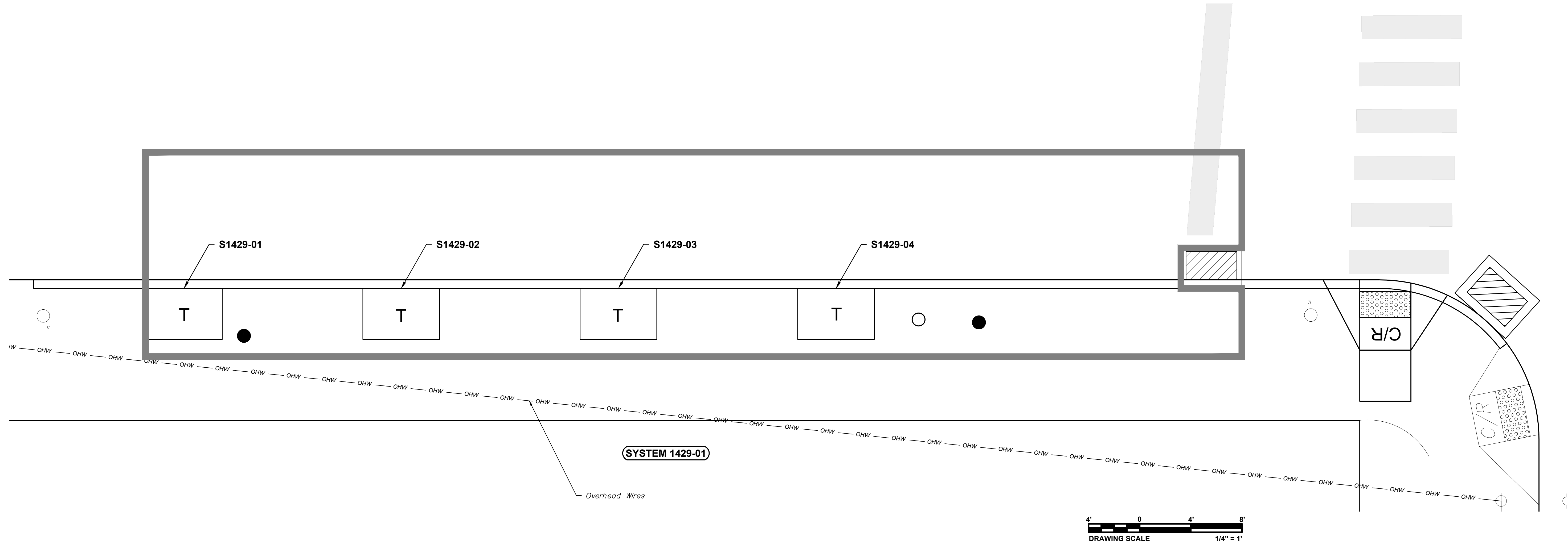
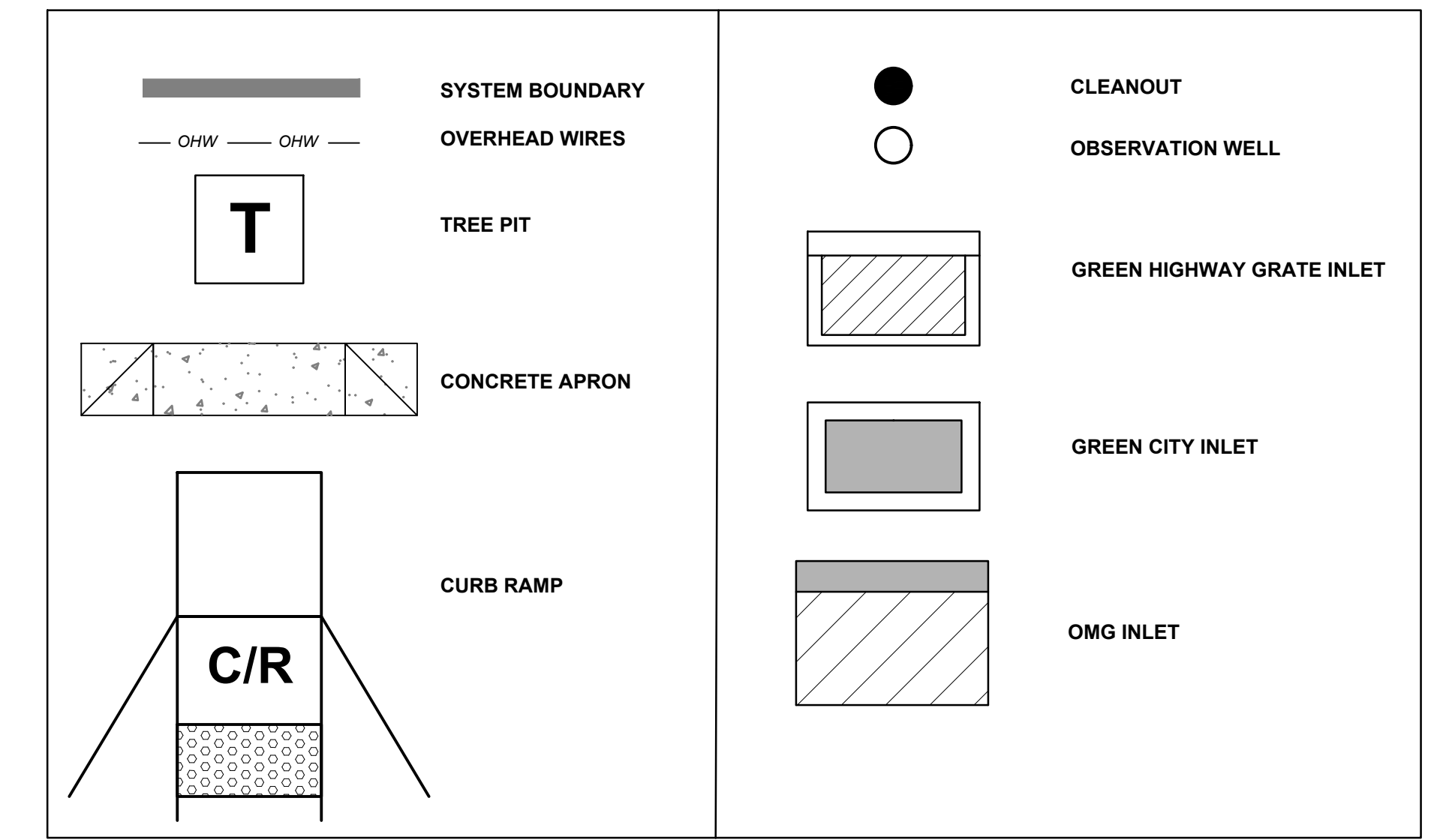

| TREE LOCATION ID | COMMON NAME    | BOTANICAL NAME                         | TREE PIT DIMENSIONS | CALIPER SIZE  | OVERHEAD WIRES | COMMENTS   |
|------------------|----------------|--|---------------------|---------------|----------------|--|
| S1429-01         | Green Hawthorn | <i>Crataegus viridis 'Winter King'</i> | 4' x 6'             | 2"-2 1/2" B&B | Yes            | Substitute with <i>Amelanchier x grandiflora 'Autumn Brilliance'</i> if planted in the fall. |
| S1429-02         | Green Hawthorn | <i>Crataegus viridis 'Winter King'</i> | 4' x 6'             | 2"-2 1/2" B&B | Yes            | Substitute with <i>Amelanchier x grandiflora 'Autumn Brilliance'</i> if planted in the fall. |
| S1429-03         | Green Hawthorn | <i>Crataegus viridis 'Winter King'</i> | 4' x 6'             | 2"-2 1/2" B&B | Yes            | Substitute with <i>Amelanchier x grandiflora 'Autumn Brilliance'</i> if planted in the fall. |
| S1429-04         | Green Hawthorn | <i>Crataegus viridis 'Winter King'</i> | 4' x 6'             | 2"-2 1/2" B&B | Yes            | Substitute with <i>Amelanchier x grandiflora 'Autumn Brilliance'</i> if planted in the fall. |

**GENERAL NOTES:**

- ADJUST LOCATIONS OF PLANTS AS NECESSARY TO AVOID DAMAGE TO EXISTING UNDERGROUND UTILITIES AND EXISTING ABOVE GROUND ELEMENTS. ADJUSTMENTS SHALL BE COMPLETED AT CONTRACTOR'S EXPENSE AND SHALL BE COORDINATED WITH THE PHILADELPHIA WATER DEPARTMENT (PWD).
- LANDSCAPE INSTALLATION SHALL BE COORDINATED WITH OTHER WORK AT THIS LOCATION.
- ALL PLANTS SHALL BE IN FULL AND STRICT COMPLIANCE WITH THE AMERICAN STANDARD FOR NURSERY STOCK (ANSI Z60.1-1996 OR LATER EDITION).
- LANDSCAPE CONTRACTOR IS RESPONSIBLE FOR GRADING AND MAY BE REQUIRED TO PROVIDE ADDITIONAL SOIL, TOP OF MULCH ELEVATION SHALL BE NO HIGHER THAN ELEVATION OF TOP OF ENERGY DISSIPATER.
- PLANT SIZES IN THE PLANT SCHEDULE ARE TO BE CONSIDERED MINIMUM SIZES.
- THE PLANT SCHEDULE IDENTIFIES PLANT SPECIES AND QUANTITIES FOR EACH LOCATION. APPROXIMATE SPACING IS AS SHOWN ON THE PLANTING PLANS.
- IF REQUESTED BY PWD, THE CONTRACTOR SHALL ENSURE PLANTS ARE TAGGED FOR REVIEW AND APPROVAL BY PWD PRIOR TO ORDERING. APPROVAL OF PLANTS AT OFF-SITE LOCATIONS DOES NOT IMPLY FINAL APPROVAL OF PLANTS AT TIME OF DELIVERY OR AT THE TIME OF INSTALLATION.
- THE CONTRACTOR SHALL BE RESPONSIBLE FOR FURNISHING WATER AND HAND WATERING OF PLANTS AFTER INSTALLATION AND UP TO FINAL COMPLETION OF THE PROJECT, AND FOR THE MAINTENANCE PERIOD (SEE SPECIFICATIONS).
- RESEED ALL DISTURBED AREAS.

**NOTICE:**

PURSUANT TO THE REQUIREMENTS OF PENNSYLVANIA ACT 50 (2017), THE CONTRACTOR SHALL CONTACT THE PENNSYLVANIA ONE CALL SYSTEM AT 1-800-242-1776, AT LEAST 3 DAYS PRIOR TO EXCAVATION.

HIGHWAY DISTRICT NO. 01 WARD NUMBER 34/52  
 SURVEY DISTRICT NO. 07 DRAINAGE SHT. NO. 33  
 OUTFALL NO. S-27/S-50 PA ONE CALL 20181993459 / 20181993460

**GREEN STORMWATER INFRASTRUCTURE PROJECT**

**UPLAND WAY GREENING  
 LANDSCAPE PLAN  
 SYSTEM 1429-01**



PLAN PREPARED FOR THE CITY OF PHILADELPHIA WATER DEPARTMENT BY:

APPROVED \_\_\_\_\_ CONSULTING ENGINEERING FIRM \_\_\_\_\_ CITY OF PHILADELPHIA WATER DEPARTMENT

EXAMPLE PLAN 2021 - NOT FOR CONSTRUCTION  
 THIS PLAN WAS DEVELOPED TO DEMONSTRATE DRAWING STANDARDS AND MAY NOT REFLECT CURRENT DESIGN STANDARDS  
**DRAFT PRE-FINAL DESIGN  
 SUBMISSION <DATE>**

INSERT COMPANY LOGO AND ADDRESS HERE

SCALES: PLAN 1/4"=1'

WORK NO. S-50258-G  
 SHEET NO. L-1 OF 6 SHEETS

|              |              |          |
|--------------|--------------|----------|
| DRAWN BY     | CAD          | XXX XXXX |
| PROJECT ENGR | PROJECT ENGR | XXX XXXX |
| SUPERVISOR   | DATE         |          |

**NOTES:**

- DO NOT HEAVILY PRUNE THE TREE AT PLANTING. PRUNE ONLY TO REMOVE CO-DOMINANT LEADERS, DEAD, AND BROKEN BRANCHES. PRUNE WITH A CLEAN CUT PER ANSI A300 & ISA (2008) STANDARDS. DO NOT CUT TREE'S CENTRAL LEADER.
- SET PLANTS PLUMB AND FACE TO GIVE THE BEST APPEARANCE OR RELATIONSHIP TO ADJACENT AREAS.
- CONTRACTOR SHALL REMOVE EXCESS SOIL FROM TOP OF ROOT BALL TO EXPOSE ROOT FLARE PRIOR TO PLANTING TO ENSURE THAT THE BASE OF THE TRUNK FLARE IS FLUSH WITH ADJACENT GRADE AND PLUMB IN ALL DIRECTIONS.
- DO NOT USE TREE WRAP. REMOVE TREE WRAP OR CARDBOARD TUBING FROM ALL TREE TRUNKS. DO NOT LEAVE MATERIALS IN THE TREE PIT.
- STAKE TREES OVER 2" CAL. SET STAKES VERTICAL AND AT SAME HEIGHT. STAKES TO BE PLACED STREET SIDE AND OPPOSITE OF STREET SIDE.
- WHERE PLANTING SOIL MEETS UNDISTURBED SOIL, SCARIFY SIDES AND BOTTOM OF TREE PIT UP TO THE BOTTOM OF ROOT BALL.
- PLANTING SOIL SHALL BE A MINIMUM DEPTH OF 3" UNLESS OTHERWISE SPECIFIED.
- THE TRUNK OF THE TREE SHALL NOT BE USED AS A LEVER IN POSITIONING OR MOVING THE TREE. CONTRACTOR SHALL LEAVE NURSERY/CONTRACTOR SEAL IN PLACE.
- PRIOR TO MULCHING, LIGHTLY TAMP SOIL AROUND ROOT BALL IN 6" LIFTS TO BRACE TREE. DO NOT OVER COMPACT. WHEN PLANTING HOLE HAS BEEN BACKFILLED, POUR WATER AROUND ROOT BALL TO SETTLE THE SOIL.
- TREE PROTECTION, WHERE REQUIRED, SHALL BE AS SHOWN ON TREE PROTECTION DETAILS.
- BARK PROTECTORS MAY BE REQUESTED BY PWD ON A PROJECT BY PROJECT BASIS.

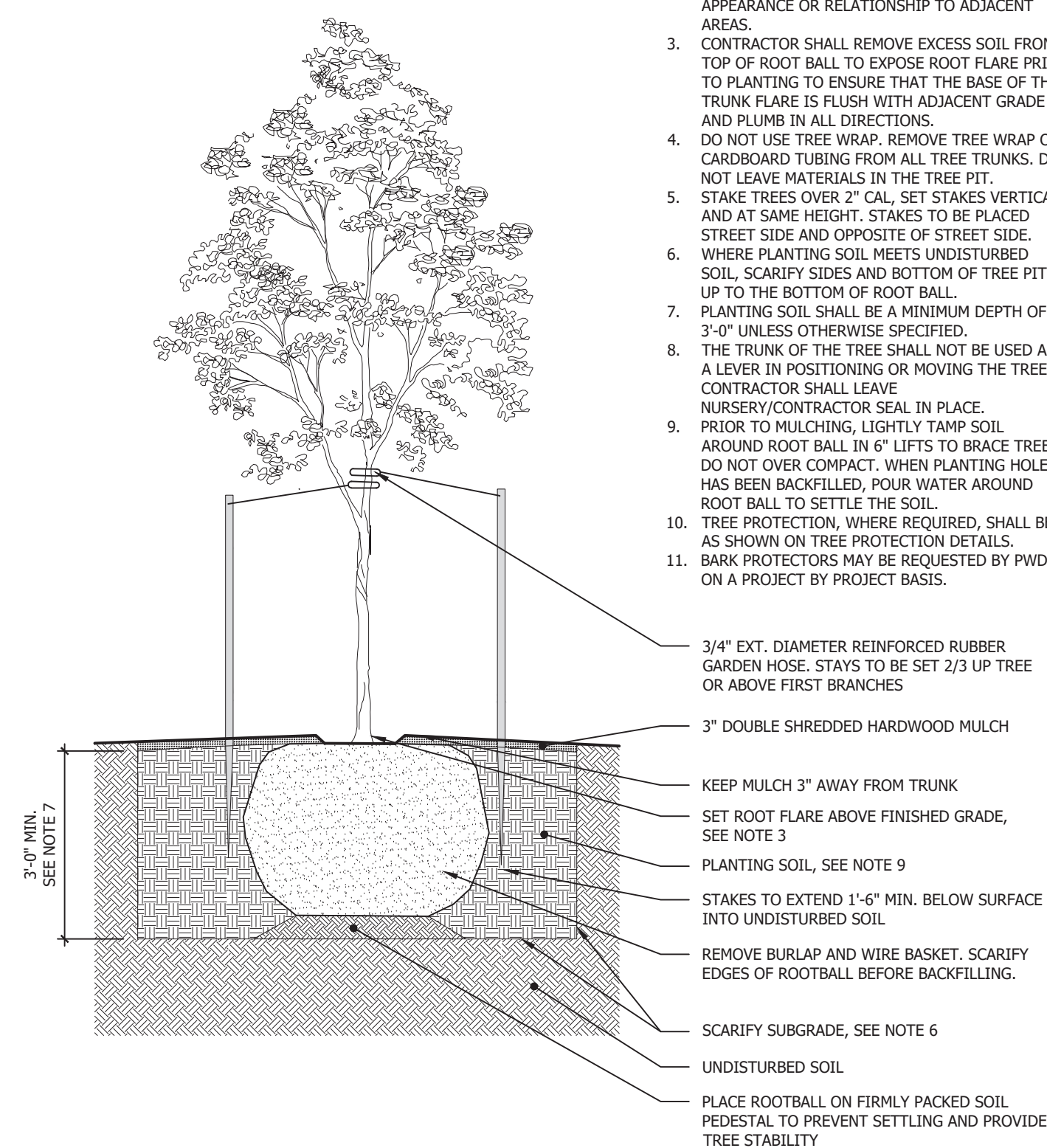

**TREE PLANTING**  
SCALE: N.T.S.

**NOTES:**

- DO NOT HEAVILY PRUNE THE TREE AT PLANTING. PRUNE ONLY CO-DOMINANT LEADERS, BROKEN, DEAD OR DAMAGED BRANCHES. PRUNE WITH A CLEAN CUT PER ANSI A300 & ISA (2008) STANDARDS. DO NOT CUT TREE'S CENTRAL LEADER.
- SET PLANTS PLUMB AND FACE TO GIVE THE BEST APPEARANCE OR RELATIONSHIP TO ADJACENT AREAS.
- CONTRACTOR SHALL REMOVE EXCESS SOIL FROM TOP OF ROOT BALL TO EXPOSE ROOT FLARE PRIOR TO PLANTING TO ENSURE THAT THE BASE OF THE TRUNK FLARE IS FLUSH WITH ADJACENT GRADE AND PLUMB IN ALL DIRECTIONS.
- DO NOT USE TREE WRAP. REMOVE TREE WRAP OR CARDBOARD TUBING FROM ALL TREE TRUNKS. DO NOT LEAVE MATERIALS IN THE TREE PIT.
- STAKE TREES OVER 2" CAL. SET STAKES VERTICAL AND AT SAME HEIGHT. STAKES TO BE PLACED STREET SIDE AND OPPOSITE OF STREET SIDE.
- WHERE PLANTING SOIL MEETS UNDISTURBED SOIL, SCARIFY SIDES AND BOTTOM OF TREE PIT UP TO THE BOTTOM OF ROOTBALL.
- PLANTING SOIL SHALL BE A MINIMUM DEPTH OF 3" UNLESS OTHERWISE SPECIFIED.
- THE TRUNK OF THE TREE SHALL NOT BE USED AS A LEVER IN POSITIONING OR MOVING THE TREE. CONTRACTOR SHALL LEAVE NURSERY/CONTRACTOR SEAL IN PLACE.
- PRIOR TO MULCHING, LIGHTLY TAMP SOIL AROUND ROOT BALL IN 6" LIFTS TO BRACE TREE. DO NOT OVER COMPACT. WHEN PLANTING HOLE HAS BEEN BACKFILLED, POUR WATER AROUND ROOT BALL TO SETTLE THE SOIL.
- TREE PROTECTION, WHERE REQUIRED, SHALL BE AS SHOWN ON TREE PROTECTION DETAILS.
- EXTENTS OF STONE STORAGE AND SAND LAYER CAN VARY.

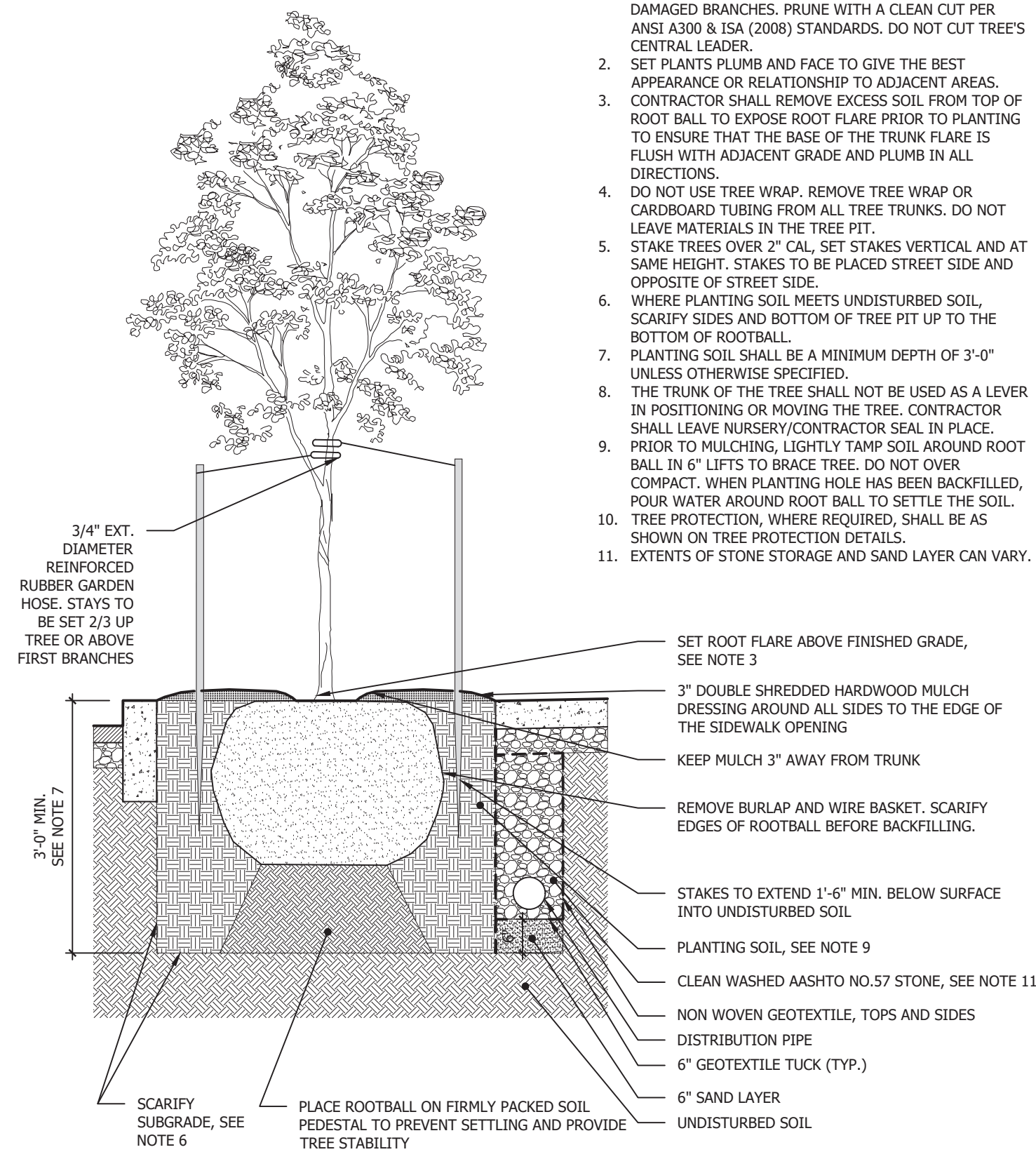

**TREE PIT IN STORMWATER TRENCH**  
SCALE: N.T.S.

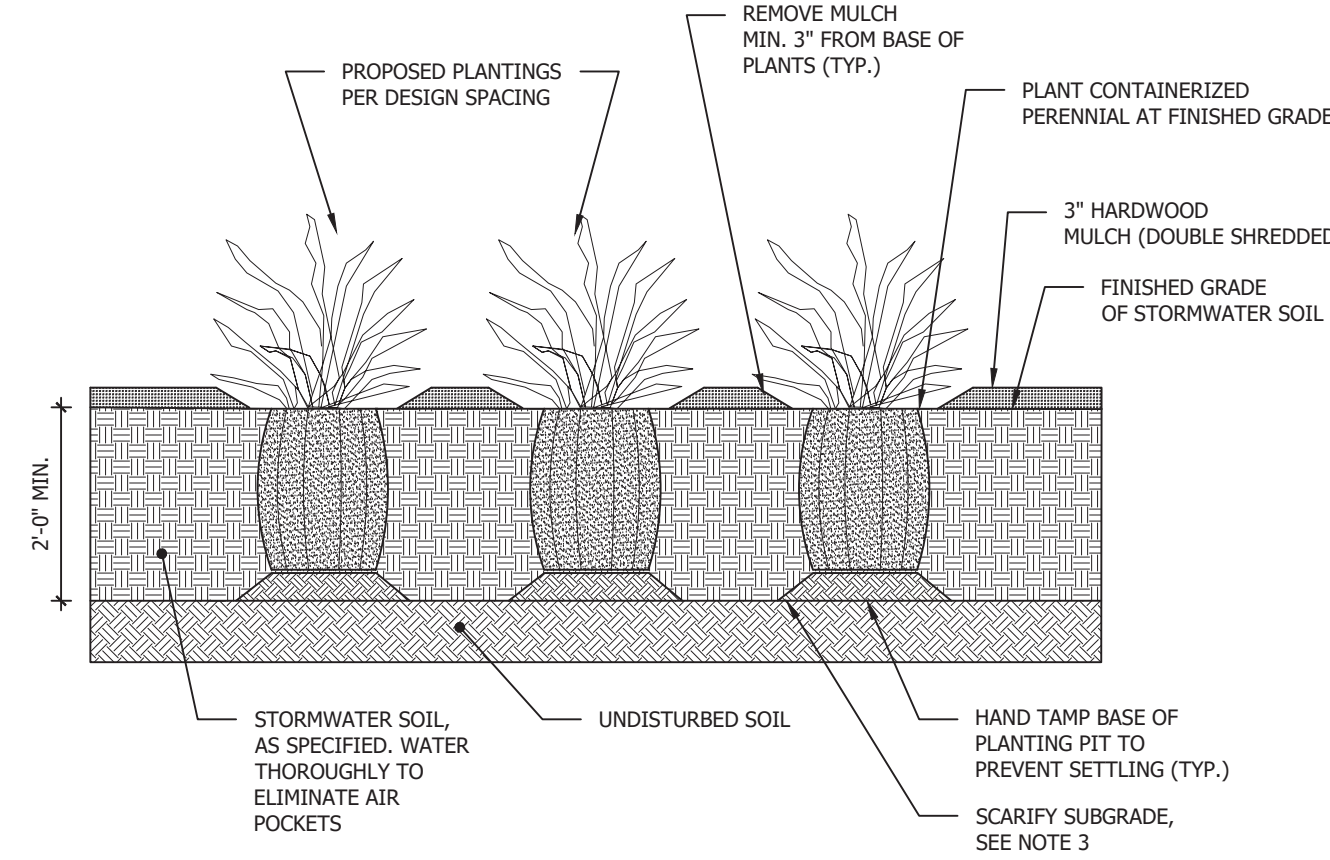

**NOTES:**

- MINIMIZE SOIL COMPACTION TO PRESERVE INFILTRATION CAPACITY OF SOIL.
- SET PLANTS PLUMB AND FACE TO GIVE BEST APPEARANCE TO ADJACENT AREAS.
- WHERE STORMWATER SOIL MEETS UNDISTURBED SOIL, SCARIFY SIDES AND BOTTOM OF EXCAVATION UP TO THE BOTTOM OF ROOTBALL.
- SCARIFY ROOTS ALONG EDGE WHERE STORMWATER SOIL MEETS CONTAINERIZED PERENNIAL BEFORE PLANTING.

**CONTAINER PLANTING**  
SCALE: N.T.S.

**NOTES:**

- SET PLANTS PLUMB AND FACE TO GIVE BEST APPEARANCE TO ADJACENT AREAS.
- WHERE STORMWATER SOIL MEETS UNDISTURBED SOIL, SCARIFY SIDES AND BOTTOM OF EXCAVATION UP TO THE BOTTOM OF THE ROOTBALL.

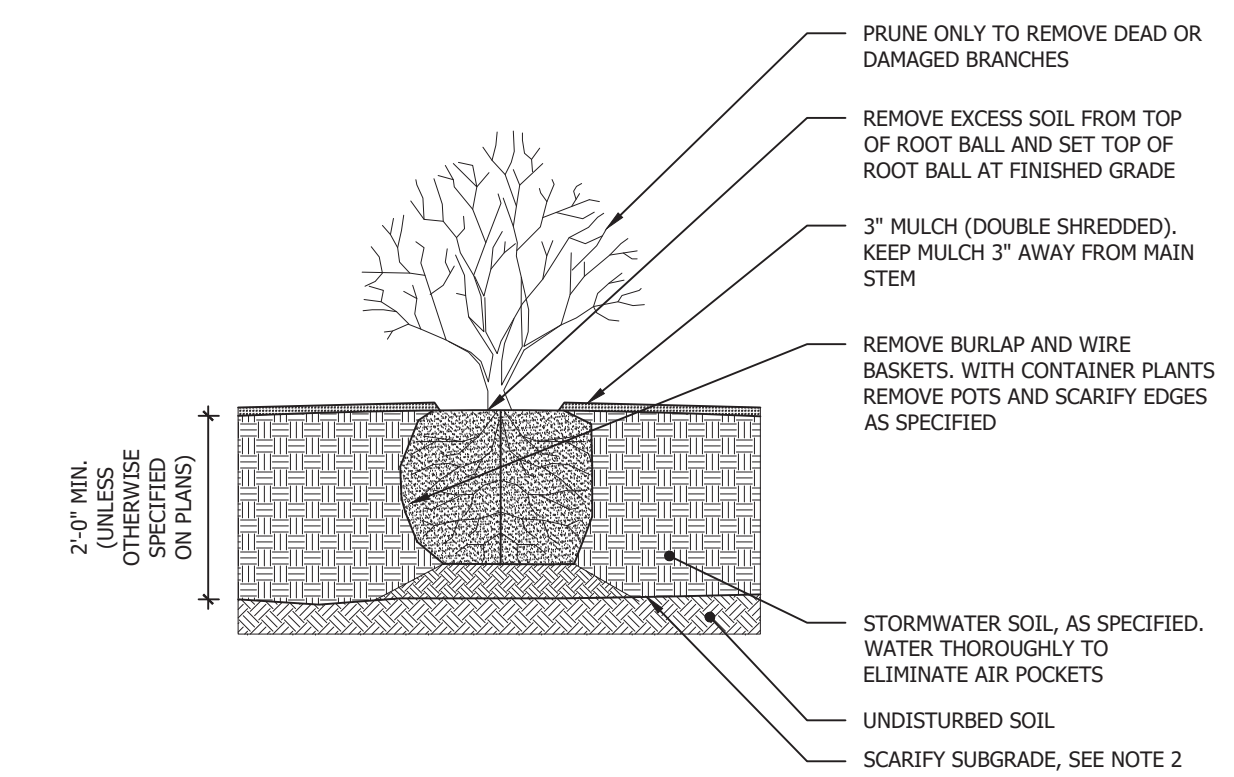

**SHRUB PLANTING**  
SCALE: N.T.S.

**GREEN STORMWATER INFRASTRUCTURE PROJECT**

**BERKS & SEDGLEY GREENING  
LANDSCAPE PLAN  
STANDARD DETAILS**



**PHILADELPHIA  
WATER  
DEPARTMENT**

PLAN PREPARED FOR  
THE CITY OF PHILADELPHIA  
WATER DEPARTMENT BY:

EXAMPLE PLAN 2021 - NOT FOR CONSTRUCTION  
THIS PLAN WAS DEVELOPED TO DEMONSTRATE DRAWING STANDARDS  
AND MAY NOT REFLECT CURRENT DESIGN STANDARDS

**DRAFT SUBSTANTIALLY COMPLETE  
DESIGN SUBMISSION <DATE>**

INSERT COMPANY LOGO  
AND ADDRESS HERE

APPROVED \_\_\_\_\_  
CONSULTING ENGINEERING FIRM

CITY OF PHILADELPHIA  
WATER DEPARTMENT

WORK NO. S-50179-G  
SHEET NO. L-X OF X SHEETS

|               |     |          |
|---------------|-----|----------|
| DRAWN BY      | CAD | XXX XXXX |
| PROJECT ENGR. |     | XXX XXXX |
| SUPERVISOR    |     | DATE     |

CONTROLLING BENCH MARK  
 X-XUT ON HYDRANT RUM LOCATED ON  
 THE N.W. CORNER OF LEON & FULLER  
 ELEV. 84.12

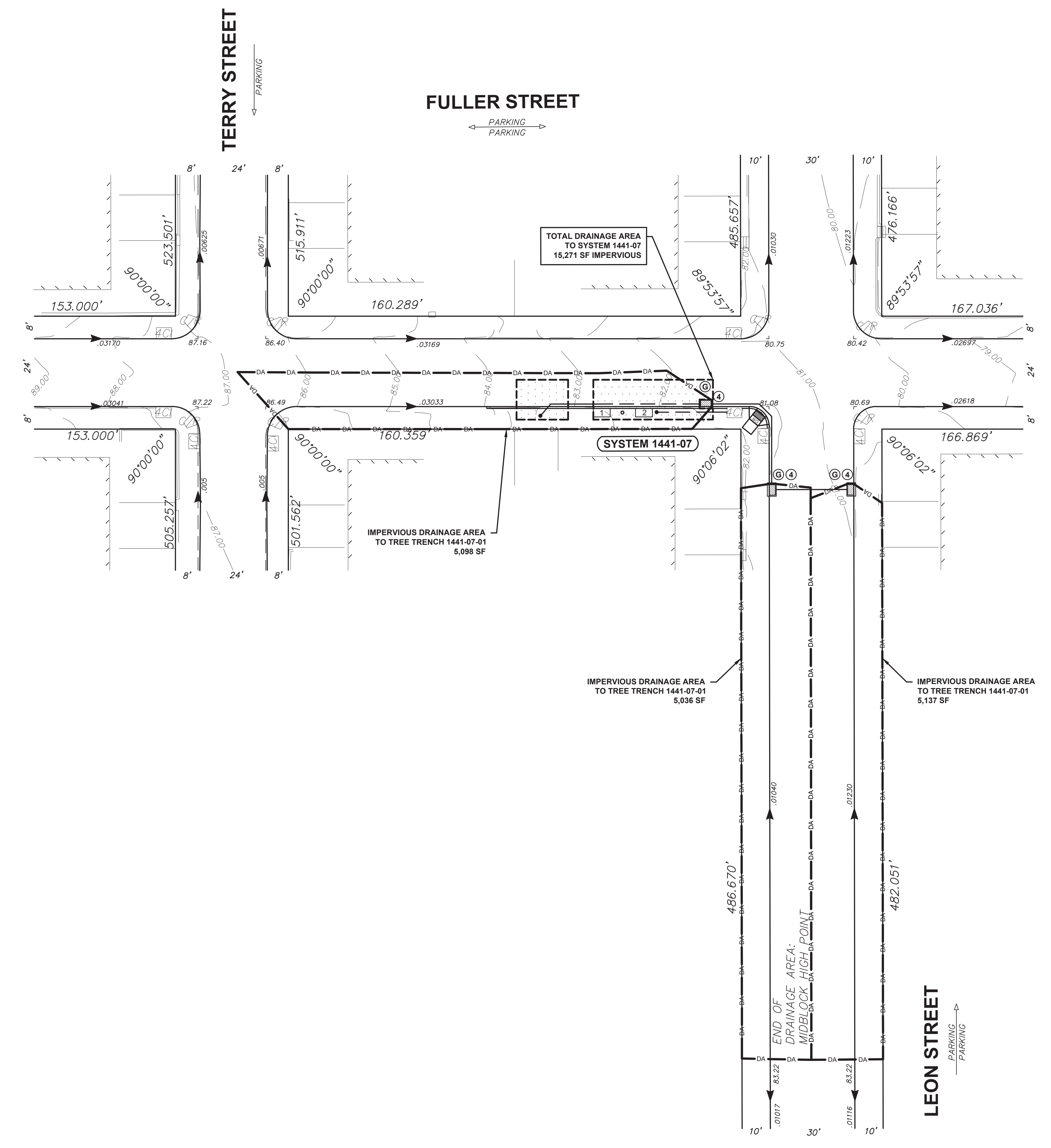
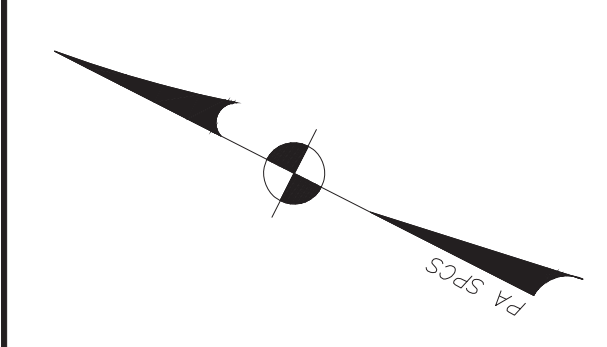

**PROPOSED LEGEND**

|  |   |  |                           |
|--|---|--|---------------------------|
|  | PERFORATED PIPE                                 |  | OMG INLET                 |
|  | SOLID PIPE                                      |  | HIGHWAY GRATE INLET       |
|  | DRAINAGE AREA LIMIT                             |  | GREEN CITY INLET          |
|  | STORMWATER TRENCH W/ GEOTEXTILE ON SIDES        |  | GREEN SHALLOW CITY INLET  |
|  | STORMWATER TRENCH W/ GEOMEMBRANE LINER ON SIDES |  | GREEN HIGHWAY GRATE INLET |
|  | GRASS STRIP                                     |  | CONCRETE APRON            |
|  |   |  | TREE PIT                  |
|  |   |  | CLEANOUT                  |
|  |   |  | OBSERVATION WELL          |

**NOTICE:**  
 PURSUANT TO THE REQUIREMENTS OF PENNSYLVANIA ACT 50 (2017), THE CONTRACTOR SHALL CONTACT THE PENNSYLVANIA ONE CALL SYSTEM AT 1-800-242-1776, AT LEAST 3 DAYS PRIOR TO EXCAVATION.

|                      |    |                   |      |                         |
|----------------------|----|-------------------|------|-------------------------|
| HIGHWAY DISTRICT NO. | 06 | WARD NUMBER       | 64   | 20182554169             |
| SURVEY DISTRICT NO.  | 04 | DRAINAGE SHT. NO. | 91   | 20182554065             |
|                      |    | OUTFALL NO.       | P-02 | PA ONE CALL 20182553135 |

**GREEN STORMWATER INFRASTRUCTURE PROJECT**

**HOLMESBURG STREETS  
 DRAINAGE AREA MAP  
 FULLER STREET  
 TERRY ST. TO LEON ST.**

APPROVED \_\_\_\_\_ CITY OF PHILADELPHIA WATER DEPARTMENT  
CONSULTING ENGINEERING FIRM

SCALES:  
 PLAN 1"=20'

WORK NO. S-50267-G  
 SHEET NO. DA-2 OF 2 SHEETS

|               |               |          |
|---------------|---------------|----------|
| DRAWN BY      | CAD           | XXX XXXX |
| PROJECT ENGR. | PROJECT ENGR. | XXX XXXX |
| SUPERVISOR    | DATE          |          |

EXAMPLE PLAN 2021 - NOT FOR CONSTRUCTION  
 THIS PLAN WAS DEVELOPED TO DEMONSTRATE DRAWING STANDARDS  
 AND MAY NOT REFLECT CURRENT DESIGN STANDARDS  
**DRAFT SUBSTANTIALLY COMPLETE  
 DESIGN SUBMISSION <DATE>**



PLAN PREPARED FOR THE CITY OF PHILADELPHIA WATER DEPARTMENT BY:

INSERT COMPANY LOGO AND ADDRESS HERE

