

INDUSTRIAL WASTES PRETREATMENT GUIDELINES

CATEGORIES OF PRETREATMENT

Grease

An approved type of grease interceptor is required on all of the following: pot sink, dishing washing sink, meat preparation sink, and most can washing equipment. The size of the grease interceptor needed is dependent of the size of the flow rate of each type of equipment.

(Types of can washers include:
trash can washers and garbage can washers)

Lint

An approved type of lint interceptor must be installed in all Laundromats and any type of commercial laundry. The size of this lint interceptor is determined by the total capacity of the machines used in total pounds.

Plaster

An approved type of plaster interceptor is required on all types of sinks where plaster is to be used.

Hair

When six (6) or more hair rinse sinks are used, an approved type of hair interceptor must be installed on each sink, or a larger interceptor may be used at the end of a line of hair rinse sinks before going to the sewer.

Oil

If no servicing or washing is done, no oil interceptor is required; but where servicing and/or washing is done, an approved type of oil interceptor is required. The size of this oil interceptor depends on the size and flow of operation. Indoor garages are not required to have oil interceptors unless washing is done on a regular basis.

GREASE INTERCEPTORS

When fixtures are near enough in the same room, they may use the same interceptor. Traps larger than required may be installed.

RESTAURANTS

Small restaurant, single sink requires a 20 gpm; 40 lbs. Grease capacity, Automatic Grease Trap (Automatic grease trap – Having flow control and auto drawoff).

Garbage can washer (or any can washer) requires a 20 gpm; 40-lbs. Grease capacity, Automatic Grease Trap.

Dishwasher requires no grease trap (unless a pre-rinse sink is not used).

Dishwashing sink or a pre-rinse of a dishwasher requires at least a 20 gpm; 40-lbs. capacity, Automatic Grease Trap.

Meat preparation sink requires a 20 gpm; 40 lbs. capacity, Automatic Grease Trap.

Take-out shop (serving steaks, hoagies, etc.) requires a letter from owner stating the use of paper plates but no trap is necessary.

Chinese restaurants' stove drains must go to grease traps.

Large restaurants where all equipment goes into one trap must have a larger size approved interceptor.

GROCERY STORE

Meat section single sink requires a 20 gpm; 40-lbs. grease capacity, Automatic Grease Trap.

BAKERY

A 3-compartment pot sink where grease is used in pans requires a 20 gpm; 40-lbs. grease capacity, Automatic Grease Trap.

When pans are floured only, a letter from owner is required but no trap.

CONVENIENCE STORE (e.g. 7-11)

A 3-compartment sink where no cooking is done does not require a grease interceptor

FOUR COMPARTMENT GREASE INTERCEPTOR
with stainless steel screens

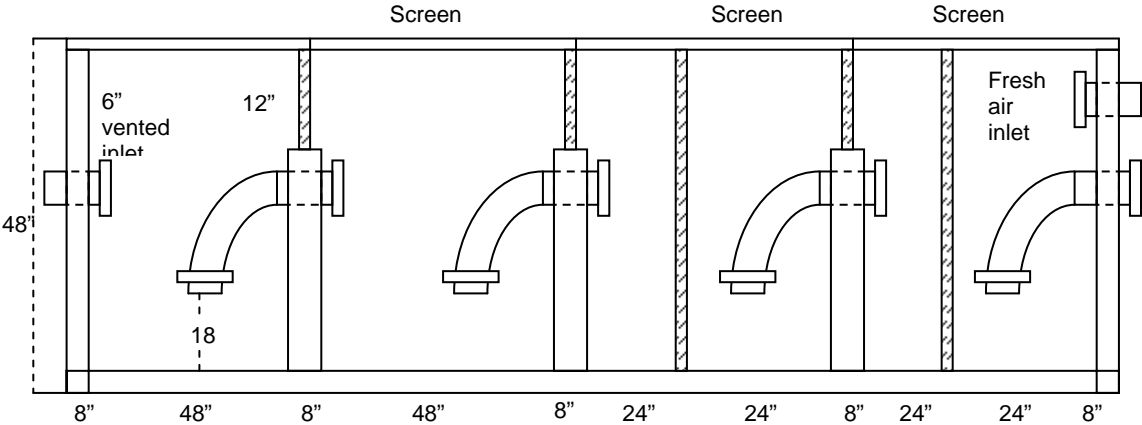

Hinged diamond plate
(4)

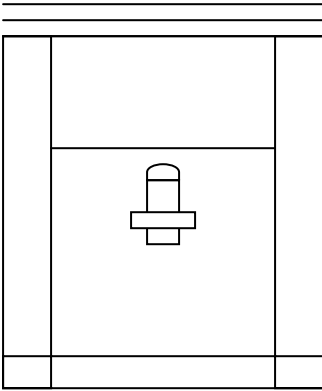

4" mesh stainless steel screens

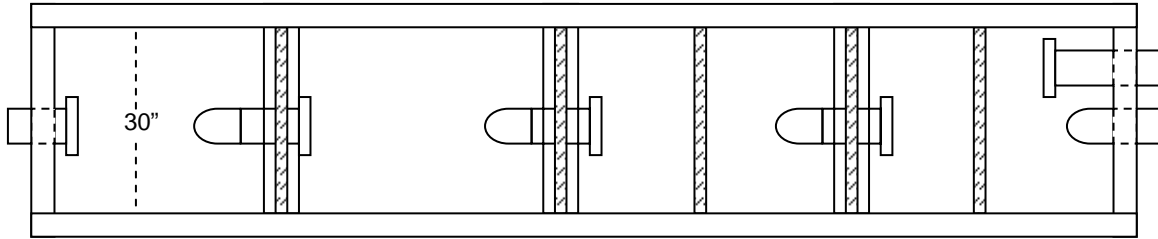

REQUIRED TREATMENT OF LINT

1

An approved type of lint interceptor must be installed in all laundromats and any type of commercial laundry. The size of the lint interceptor is determined by the total capacity of all the machines in total pounds; use this weight to determine size of lint interceptor required: e.g. 12 M x 12 lbs. = 144 lbs.

LAUNDROMAT

- 0 - 39 lbs. = Nothing required
- 40 - 120 lbs. = requires a 75 gpm; 150-lbs. grease capacity, grease trap
- 121 - 240 lbs. = requires a 150 gpm; 300-lbs. grease capacity, grease trap
- 241 - 360 lbs. = requires a 250 gpm; 500-lbs grease capacity, grease trap
- 361 - 520 lbs. = requires a 350 gpm; 700-lbs grease capacity, grease trap

Where more than 39 lbs. total machine capacity on any one floor goes to a common waste line, an approved lint interceptor must be used.

Any total machine capacity of 241 lbs. to 360 lbs. must use a 250 gpm; 500 –lbs grease capacity grease trap.

Any total machine capacity of 241 lbs. to 360 lbs. must use a 350 gpm; 700-lbs grease capacity, grease trap.

COMMERCIAL LAUNDRY

If a discharger chooses not to use the approved lint interceptor, a trough with a single set (s) of ¼” inch perforated mesh stainless steel screens must be installed. If ¼” inch mesh stainless steel screens are used in a trough, they must be placed 12” inches apart at the drain end of the trough leading to the City sewer. One set of two stainless steel screens must be used in the trough at all times.

Commercial Laundries
Trough with stainless steel screens

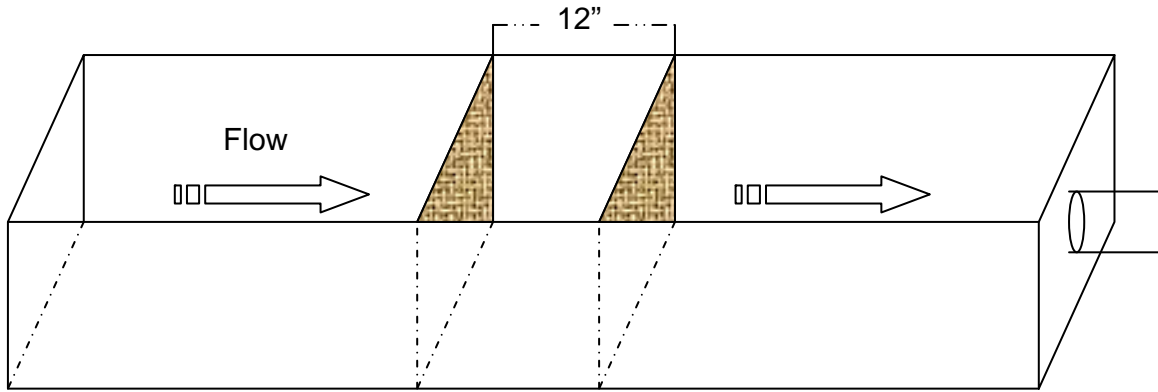

Trough with Stainless Steel Screens

**¼ Inch Perforated Mesh Stainless Steel Screens
 For all machines with 12 pound capacity**

up to	39 pounds (3 Machines)	Nothing
up to	120 pounds (10 Machines) grease capacity	75 gpm;150-lbs.
up to	240 pounds (20 Machines) grease capacity	150 gpm;300-lbs.
up to	360 pounds (30 Machines) grease capacity	250 gpm;500-lbs.
up to	520 pounds (43 Machines) grease capacity	350gpm;700-lbs.

Commercial Size Lint

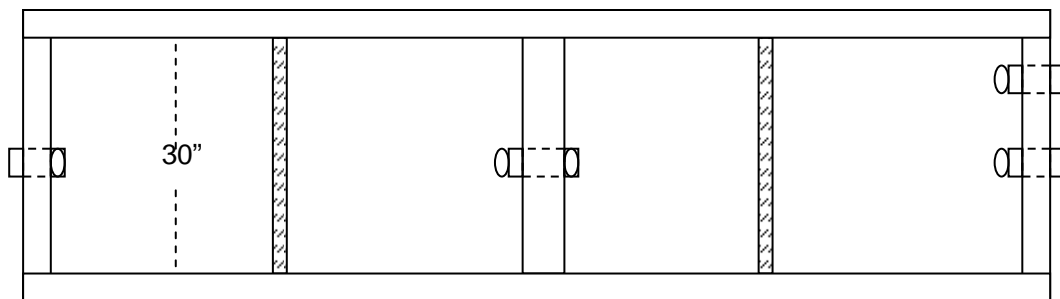
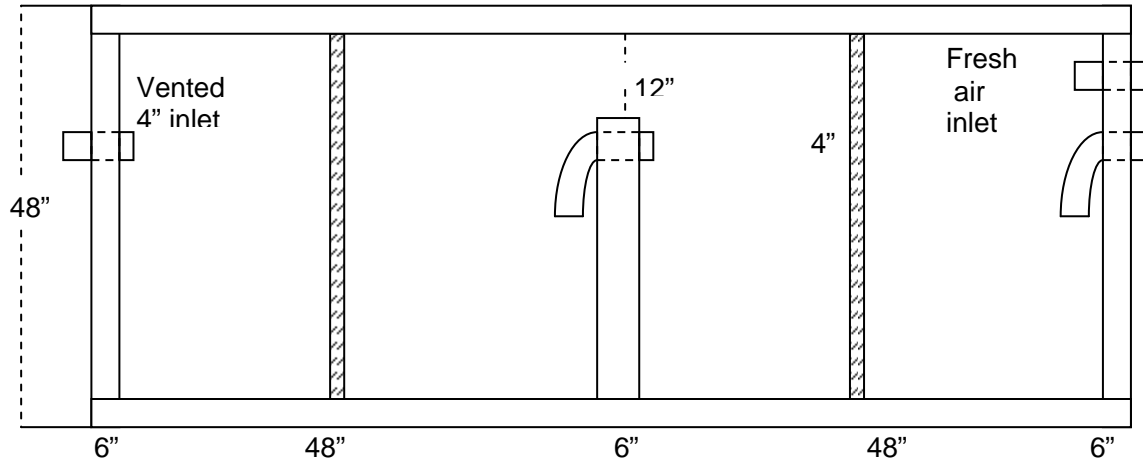

All walls must be made out of either:

- Reinforced Concrete (6")
- Poured Concrete
- Concrete Block (75% Concrete – 8")

REQUIRED TREATMENT OF PLASTER

An approved type of plaster interceptor is required on any type of sink where plaster is used.

SMALL DENTAL OFFICES

A plaster interceptor is required on a sink only when false teeth are made by the dentist.

SCHOOL ARTS AND CRAFTS ROOMS

An approved plaster interceptor is required on each sink.

LARGE DENTAL OFFICES AND SCHOOLS

An approved larger plaster interceptor can be used at the end of a line of sinks on a common effluent line before going to a City sewer.

REQUIRED TREATMENT OF HAIR

When six or more hair rinse sinks are used, any approved type of hair interceptor is required on all sinks.

Any approved large type of hair interceptor may be used to cover a line of hair rinse sinks. It is to be installed in the drain line below the lowest sink in the main line to the sewer.

REQUIREMENTS FOR VARIOUS TYPES OF AUTOMOTIVE SERVICE CENTERS

SERVICE STATIONS

All indoor floor drains in servicing area must go to a three or four chamber interceptor.

MOTOR REPAIR SHOPS

If engine work or washing is done, an approved type three or four compartment oil interceptor is required.

BODY & FENDER SHOP

No oil interceptor is required if no servicing or washing is done.

PARKING GARAGES & LOTS

No oil interceptor is required if no servicing or washing is done.

AUTOMATIC CAR WASHES

- | | | |
|-------------------------|---|---------------------------------------|
| Small self-service type | - | 3 chamber oil interceptor is required |
| Large 3 min type | - | 4 chamber oil interceptor is required |

PRIVATE GARAGES 1 or 2 CARS, ETC.

No oil interceptor is required.

CAR AND TRUCK STEAM CLEANING

A special type of oil interceptor is required on all outdoor types. All waste must flow to a proper approved size oil interceptor.

LARGE PUBLIC GARAGES, BUS & TRUCK TERMINALS

If no servicing or washing is done, no interceptor is required. A 3 or 4 type compartment oil interceptor is to be used when servicing and/or washing is done. The size of the interceptor depends on the size of business. The smallest size interceptor allowed is the 3 compartment oil interceptor.

OIL INTERCEPTORS

The size of the oil interceptor used depends on the size and flow from the operation.

A three (3) compartment oil interceptor is required in all service stations.

In larger installations that do servicing and washing such as:

Public garages, bus terminal garages, truck and tractor-trailer depots require a much larger type of oil interceptor such as a three (3) or four (4) compartment interceptor.

On the following pages are specifications for various types of approved oil interceptors.

The Industrial Waste Unit prefers the use of the use of the concrete three or four compartment oil interceptors.

City of Philadelphia
Three Compartment Interceptor

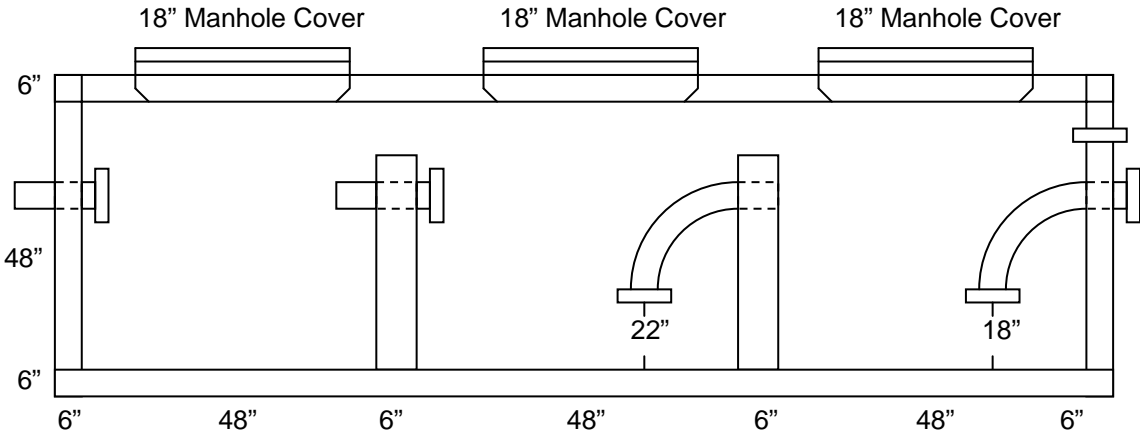

All Walls must be made out of either:

- 1. Reinforced Concrete (6")
- 2. Poured Concrete (6")
- 3. Concrete block – 75% concrete (8")

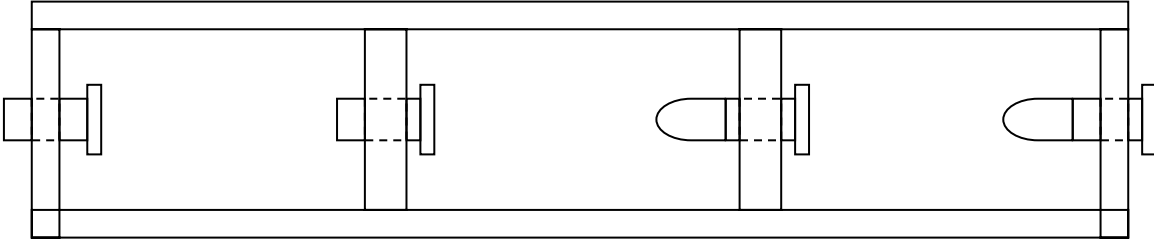

Outdoor Steam Cleaning Area Drain

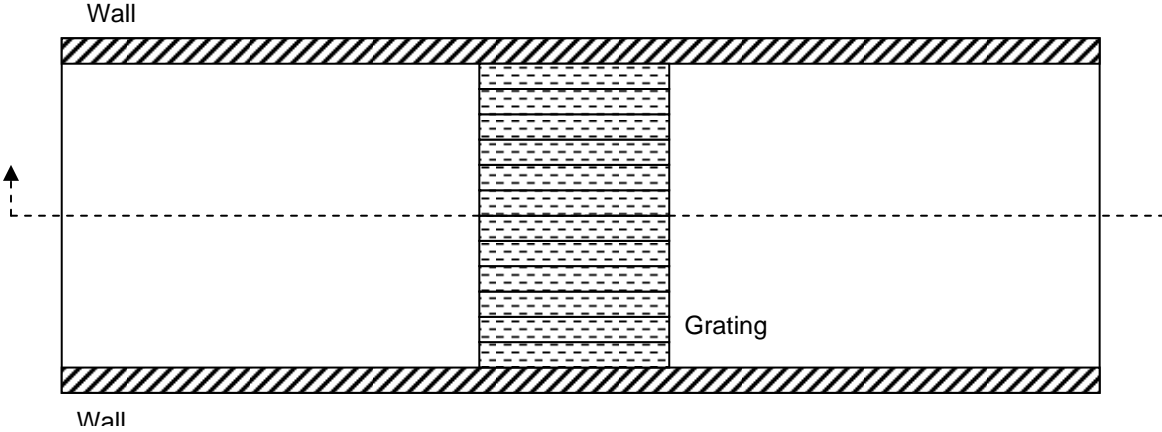

Top View

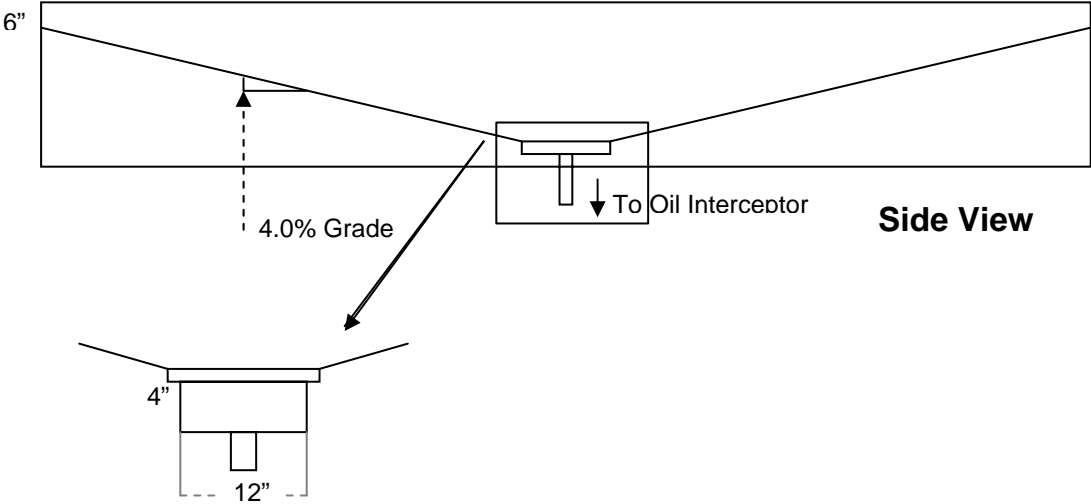

Side View

REQUIRED TREATMENT OF ACIDIC AND BASIC WASTE

All industries with liquid waste effluents below a pH of less than 6 or more than 9 standard units must have some type of pre-treatment interception of their waste before it enters the City sewer system.

MISCELLANEOUS ACTIVITIES

PAINTING

Mist Spray Area

No floor drains allowed in paint spraying area.

Water Fall Spray Area

A holding tank is required in line before going to sewer, and a coagulant is to be used to solidify the paint solids which in turn float to the top and are then skimmed off and put in the trash, after which the water is then recirculated.

MEAT PROCESSING

All floor drains must be an approved bucket type to catch any solids. They also must have an approved type grease interceptor on any type preparation.

SUPER-MARKETS

Meat Dept.

All meat preparation sinks must have an approved type grease interceptor.

Fish Dept.

Any fish-cleaning sink must have a ¼" inch perforated stainless steel wire basket in sink when cleaning fish and solids must be put into trash can.

LABORATORIES

Sinks do not require neutralization of acids or caustic waste, if used only in small quantities.

HOSPITAL, DENTIST, SCHOOLS, ETC.

Nothing is needed unless plaster is used, in which case an approved type of Plaster trap is required such a minimum 10 gpm; 20-lbs. grease capacity, grease trap

PHOTOGRAPHY, SHOPS AND STUDIOS

Nothing is needed in a small type studio. Larger type and commercial studios must have a neutralizing tank for all the liquid waste to flow into before going to the City sewer and silver recovery units.