

A. Maltman

A. F. Burbidge
J 795A

STANDARD DETAILS

FOR

SEWERS

DEPARTMENT OF PUBLIC WORKS

Bureau of Surveys

PHILADELPHIA

1907

GEORGE S. WEBSTER,
CHIEF ENGINEER.

GENERAL SECTIONS OF CIRCULAR SEWERS

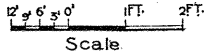

DEPARTMENT OF PUBLIC WORKS
BUREAU OF SURVEYS
PHILADELPHIA
1906

S. H. Webster
Chief Engineer.

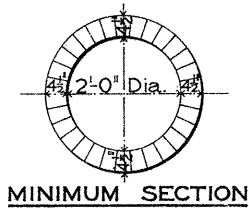

MINIMUM SECTION

All Slants for Inlet connections to be
15" dia. for N^o1 and N^o2 Inlets,
12" dia. for N^o3 Inlets, and
8" dia. for N^o4 Inlets.

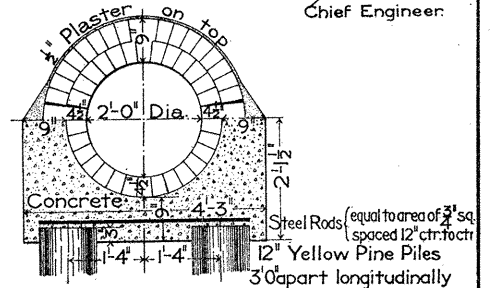

SECTION IN REDUCED CRADLE

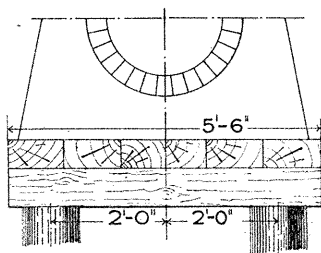

SECTION SHOWING PLATFORM and PILES



VITRIFIED SHALE BRICK INVERT

6" Yellow Pine Planking laid close
8" x 8" Yellow Pine Stringers
3'-0" apart longitudinally
12" Yellow Pine Piles
3'-0" apart longitudinally.

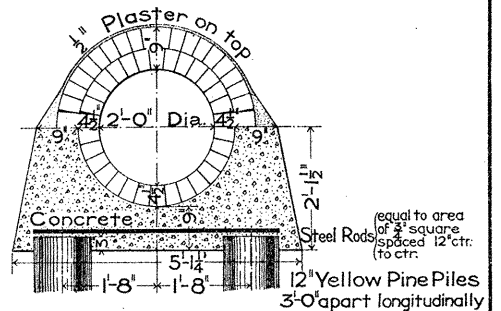

SECTION IN MAXIMUM CRADLE

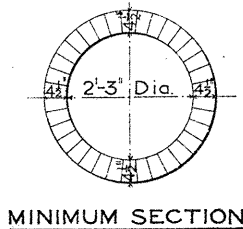

MINIMUM SECTION

Steel Rods (equal to area of 3" square), and
Piles, or Piles and Platform, if required,
will be paid for at the price in the
contract when ordered by the
Chief Engineer.

Filling over top of Sewer to be
at least 3 feet deep and with
a slope not less than 1/2 ft. horizontal
over 1 ft. vertical extending to the
surface of the ground.

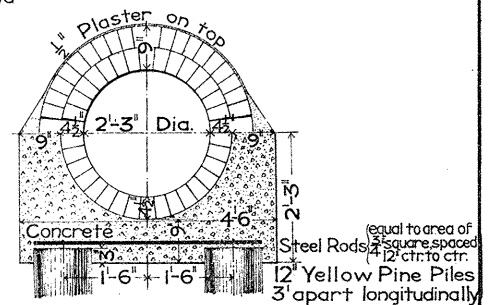

SECTION IN REDUCED CRADLE

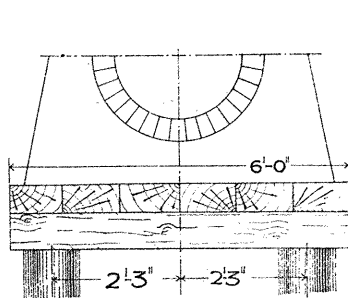

SECTION SHOWING PLATFORM and PILES



VITRIFIED SHALE BRICK INVERT

6" Yellow Pine Planking laid close
8" x 8" Yellow Pine Stringers
3'-0" apart longitudinally
12" Yellow Pine Piles
3'-0" apart longitudinally

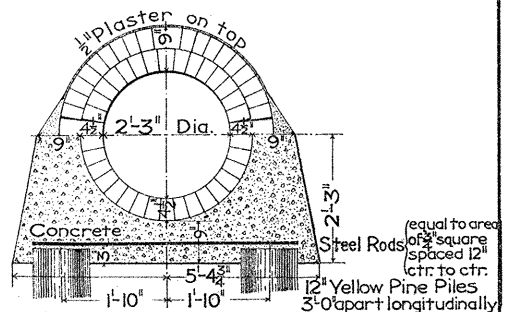

SECTION IN MAXIMUM CRADLE

GENERAL SECTIONS OF CIRCULAR SEWERS

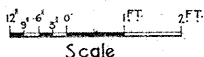

DEPARTMENT OF PUBLIC WORKS
BUREAU OF SURVEYS
PHILADELPHIA
1906

D. C. Whitely
Chief Engineer

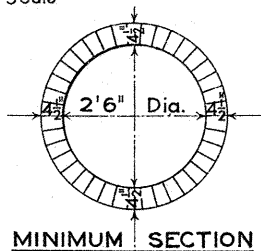

MINIMUM SECTION

All Slants for Inlet connections to be 15" dia. for N^o 1 and N^o 2 Inlets, 12" dia for N^o 3 Inlets, and 8" dia. for N^o 4 Inlets.

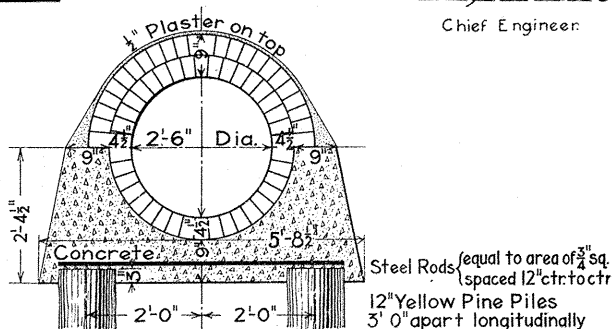

SECTION IN MAXIMUM CRADLE

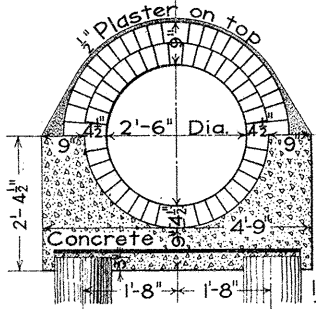

SECTION IN REDUCED CRADLE

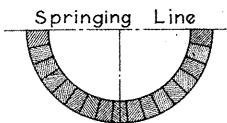

VITRIFIED SHALE BRICK INVERT

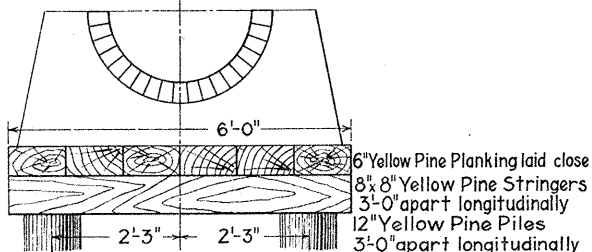

SECTION SHOWING PLATFORM and PILES

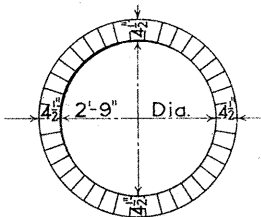

MINIMUM SECTION

Steel Rods (equal to area of 3/4" square) and Piles, or Piles and Platform, if required, will be paid for at the price in the contract when ordered by the Chief Engineer.

Filling over top of Sewer to be at least 3 feet deep and with a slope not less than 1 1/2 ft. horizontal over 1 ft. vertical extending to the surface of the ground.

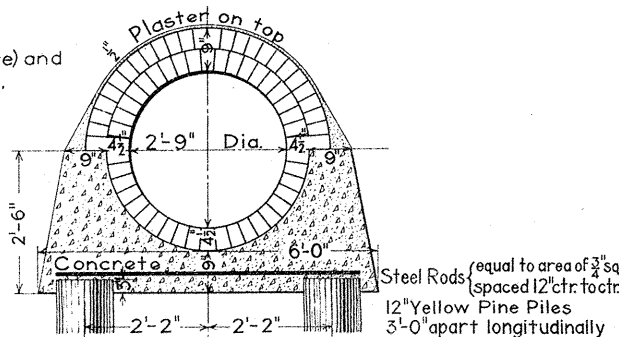

SECTION IN MAXIMUM CRADLE

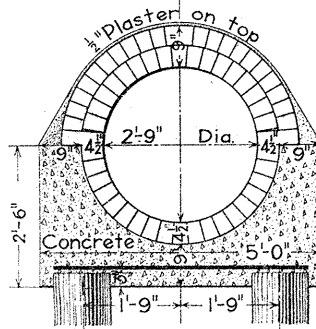

SECTION IN REDUCED CRADLE

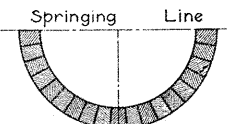

VITRIFIED SHALE BRICK INVERT

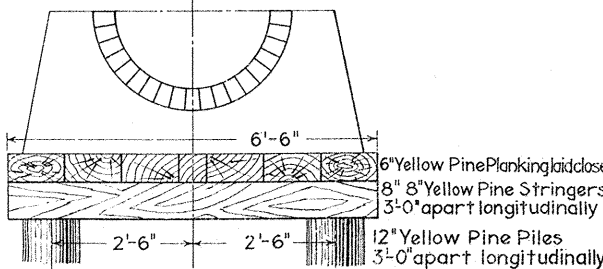

SECTION SHOWING PLATFORM and PILES

GENERAL SECTIONS OF CIRCULAR SEWERS

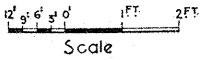

DEPARTMENT OF PUBLIC WORKS
BUREAU OF SURVEYS
PHILADELPHIA
1906

E. C. Minton
Chief Engineer

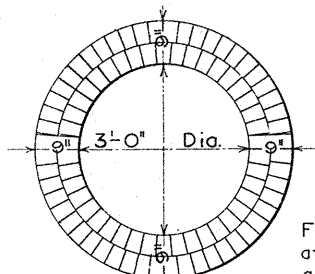

MINIMUM SECTION

Filling over top of Sewer to be at least 3 feet deep and with a slope not less than 1/2 ft. horizontal over 1 ft. vertical extending to the surface of the ground.

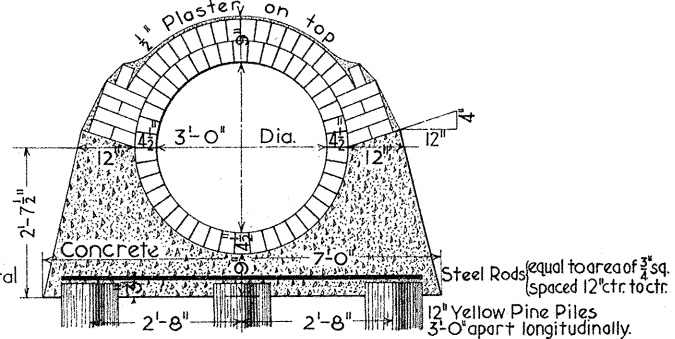

SECTION IN MAXIMUM CRADLE

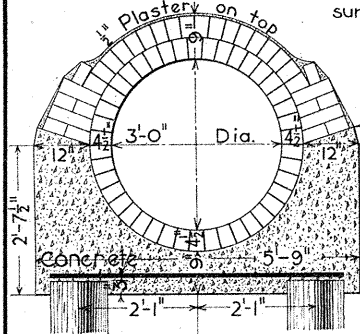

SECTION IN REDUCED CRADLE

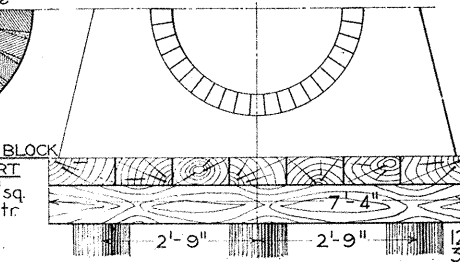
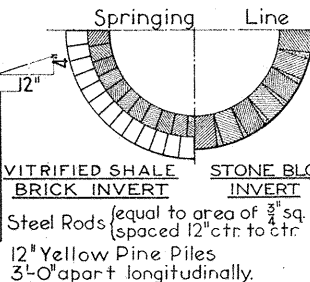

SECTION SHOWING PLATFORM and PILES

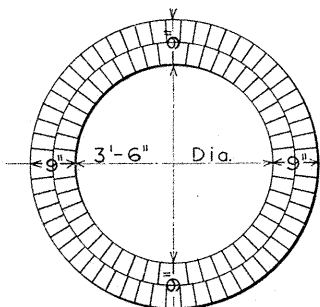

MINIMUM SECTION

Steel Rods (equal to area of 3/4 square) and Piles, or Piles and Platform, if required will be paid for at the price in the contract when ordered by the Chief Engineer.

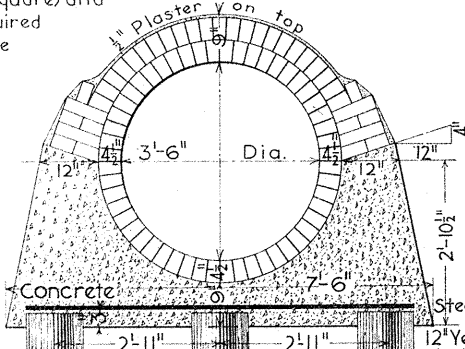

SECTION IN MAXIMUM CRADLE

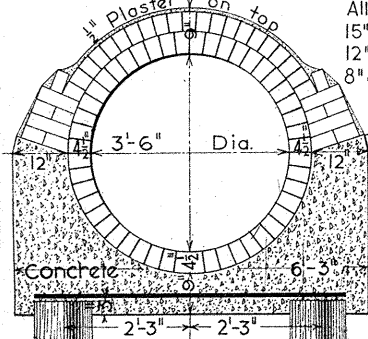

SECTION IN REDUCED CRADLE

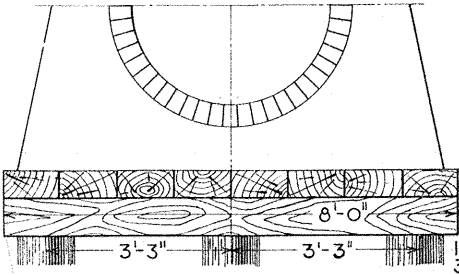
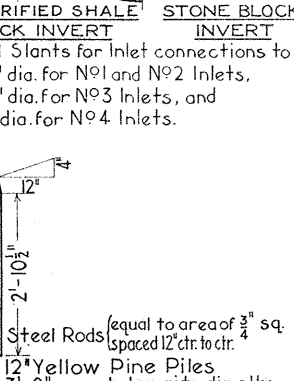

SECTION SHOWING PLATFORM and PILES

GENERAL SECTIONS OF CIRCULAR SEWERS

DEPARTMENT OF PUBLIC WORKS
BUREAU OF SURVEYS

S. C. Webster
Chief Engineer

Scale
0' 9" 6" 3" 0" 1 FT. 2 FT.

PHILADELPHIA
1906

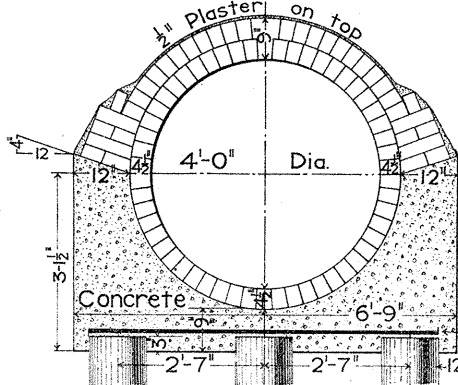
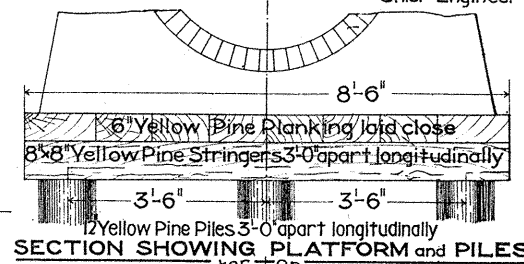
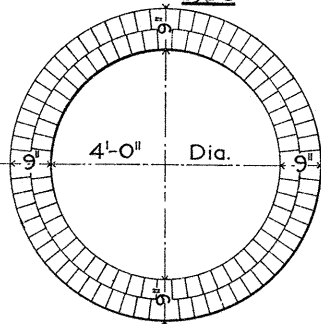
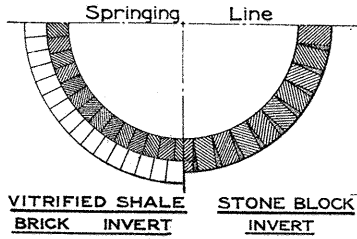

MINIMUM SECTION

Steel Rods (equal to area of $\frac{3}{4}$ " square) and Piles, or Piles and Platform, if required, will be paid for at the price in the contract when ordered by the Chief Engineer.

Steel Rods—equal to area of $\frac{3}{4}$ " sq. spaced 12" c. to c.

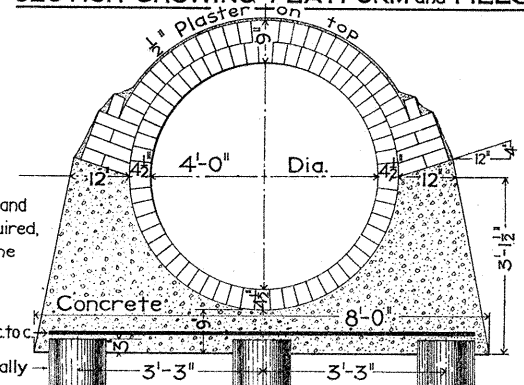

SECTION IN MAXIMUM CRADLE

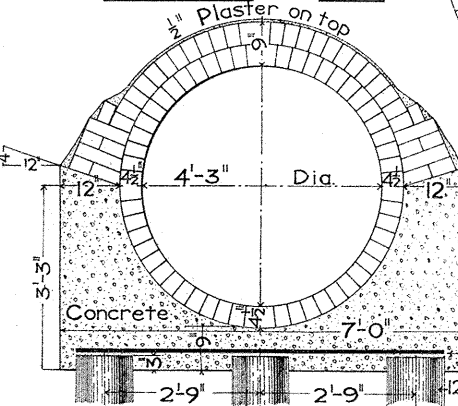
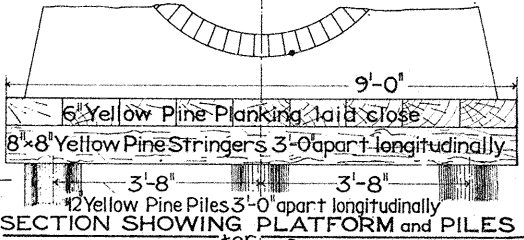
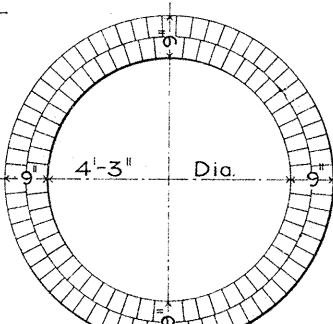
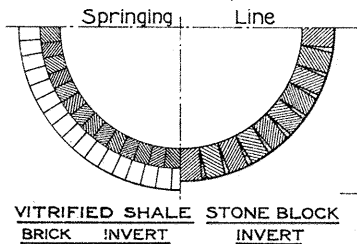

MINIMUM SECTION

Filling over top of Sewer to be at least 3 feet deep and with a slope not less than $\frac{1}{2}$ ft. horizontal over 1 ft. vertical extending to the surface of the ground.

All Slants for Inlet connections to be 15" dia. for N^o1 and N^o2 Inlets, 12" dia. for N^o3 Inlets, and 8" dia. for N^o4 Inlets.

Steel Rods equal to area of $\frac{3}{4}$ " sq. spaced 12" c. to c.

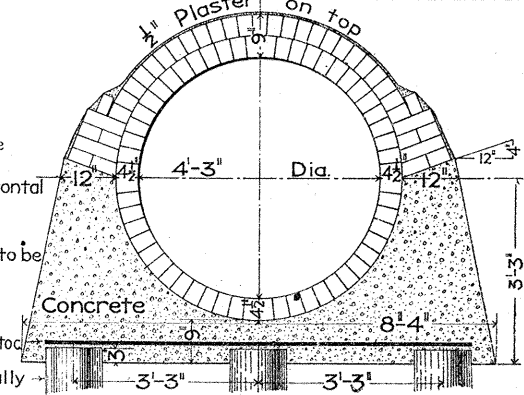

SECTION IN MAXIMUM CRADLE

GENERAL SECTIONS OF CIRCULAR SEWERS

12'-0" 6'-0" 1 FT. 2 FT.
Scale

DEPARTMENT OF PUBLIC WORKS
BUREAU OF SURVEYS
PHILADELPHIA
1906

E. A. Heston
Chief Engineer.

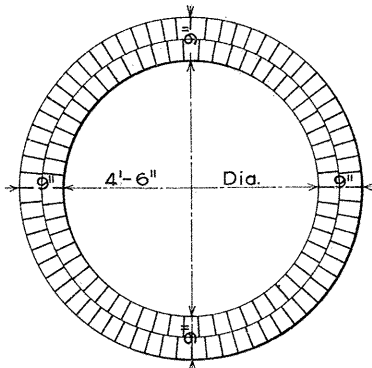

MINIMUM SECTION

6" Yellow Pine Planking laid close
8" x 8" Yellow Pine Stringers
3'-0" apart + longitudinally
12" Yellow Pine Piles
3'-0" apart longitudinally

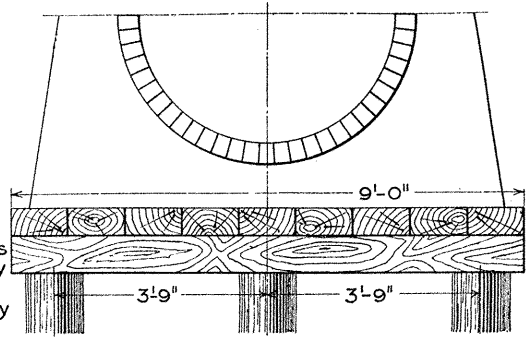

SECTION SHOWING PLATFORM and PILES

Filling over top of Sewer to be at least 3 feet deep and with a slope not less than 1/2 ft. horizontal over 1 ft. vertical extending to the surface of the ground.

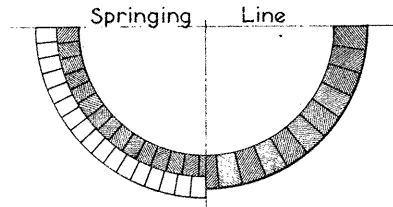

VITRIFIED SHALE BRICK INVERT STONE BLOCK INVERT

Steel Rods (equal to area of 3/4" square) and Piles, or Piles and Platform, if required, will be paid for at the price in the contract when ordered by the Chief Engineer.

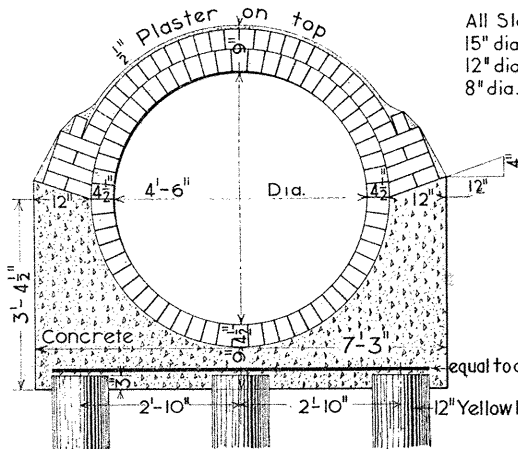

SECTION IN REDUCED CRADLE

All Slants for Inlet connections to be 15" dia. for N°1 and N°2 Inlets, 12" dia. for N°3 Inlets, and 8" dia. for N°4 Inlets.

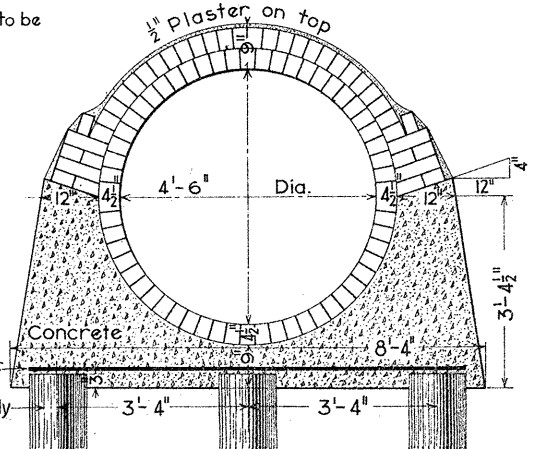

SECTION IN MAXIMUM CRADLE

Steel Rods equal to area of 3/4" sq. spaced 12" ctr to ctr.
12" Yellow Pine Piles 3'-0" apart longitudinally

GENERAL SECTIONS OF CIRCULAR SEWERS

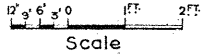

DEPARTMENT OF PUBLIC WORKS
BUREAU OF SURVEYS
PHILADELPHIA
1906

E. J. Walker
Chief Engineer

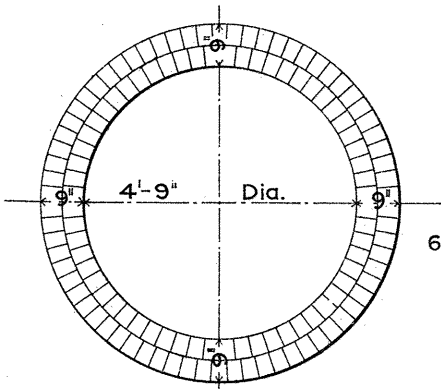

MINIMUM SECTION

6" Yellow Pine Planking laid close
8" x 8" Yellow Pine Stringers
3'-0" apart longitudinally
12" Yellow Pine Piles
3'-0" apart longitudinally

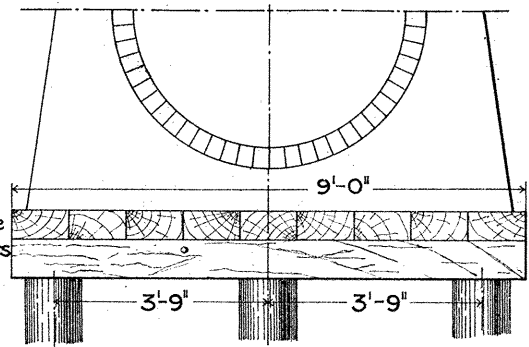

SECTION SHOWING PLATFORM and PILES

Filling over top of Sewer to be at least 3 feet deep and with a slope not less than 1/2 ft. horizontal over 1 ft. vertical, extending to the surface of the ground.

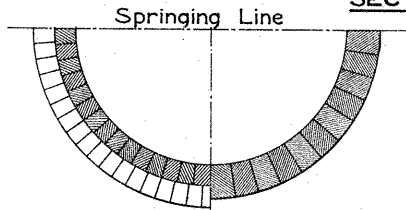

Steel Rods (equal to area of 3/4" square) and Piles, or Piles and Platform, if required, will be paid for at the price in the contract when ordered by the Chief Engineer.

VITRIFIED SHALE BRICK INVERT STONE BLOCK INVERT

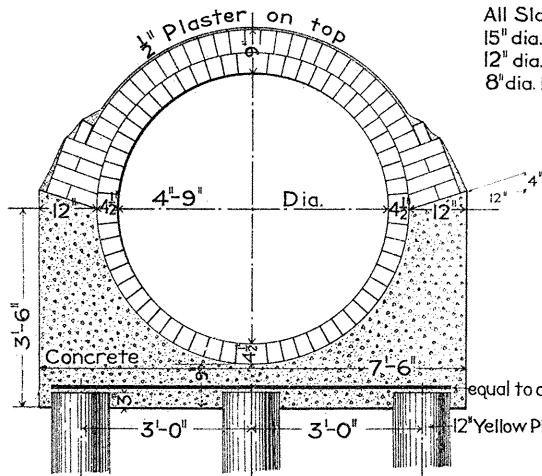

SECTION IN REDUCED CRADLE

All Slants for Inlet connections to be 15" dia. for N^o1 and N^o2 Inlets, 12" dia. for N^o3 Inlets, and 8" dia. for N^o4 Inlets.

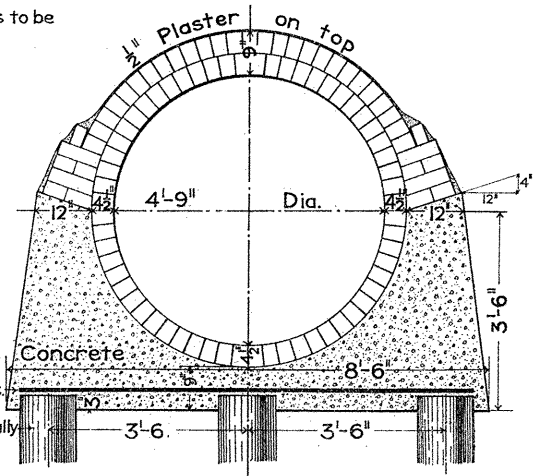

SECTION IN MAXIMUM CRADLE

GENERAL SECTIONS OF EGG-SHAPED SEWERS

DEPARTMENT OF PUBLIC WORKS
BUREAU OF SURVEYS
PHILADELPHIA
1906

L. P. Mott
Chief Engineer

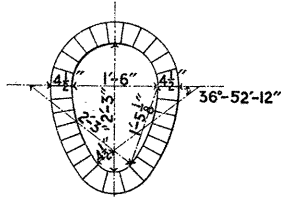
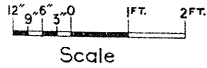

MINIMUM SECTION

All Slants for Inlet Connections to be 15" dia. for No 1 and No 2 Inlets, 12" dia. for No 3 Inlets, and 8" dia. for No 4 Inlets.

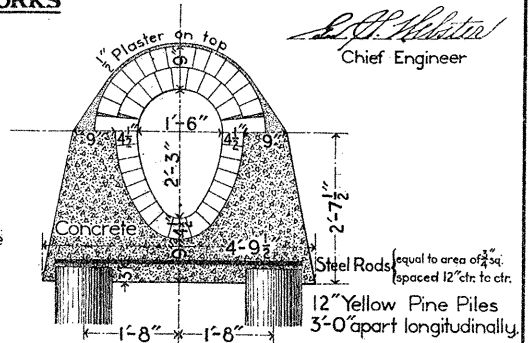

SECTION IN MAXIMUM CRADLE

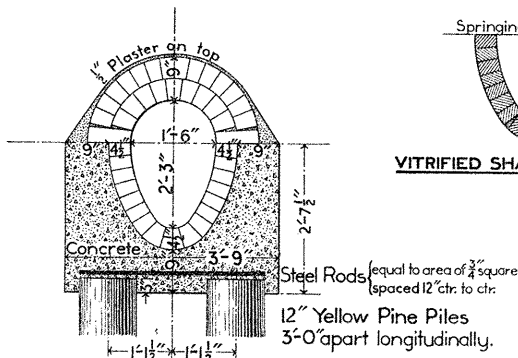

SECTION IN REDUCED CRADLE

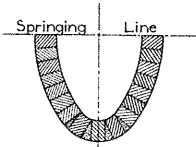

VITRIFIED SHALE BRICK INVERT.

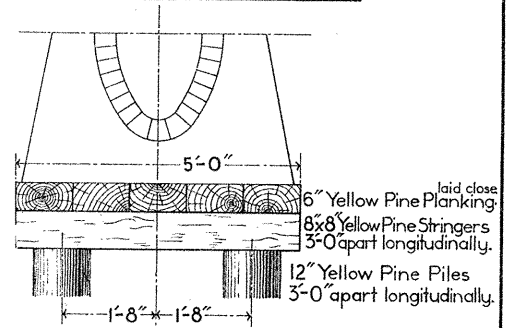

SECTION SHOWING PLATFORM AND PILES

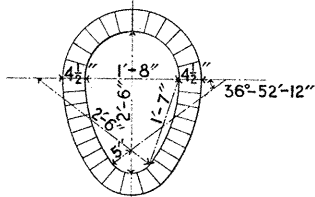

MINIMUM SECTION

Steel Rods (equal to area of $\frac{3}{4}$ " square) and Piles, or Piles and Platform, if required, will be paid for at the price in the contract when ordered by the Chief Engineer.

Filling over top of Sewer to be at least 3 feet deep and with a slope not less than $\frac{1}{2}$ ft. horizontal over 1 ft. vertical, extending to the surface of the ground.

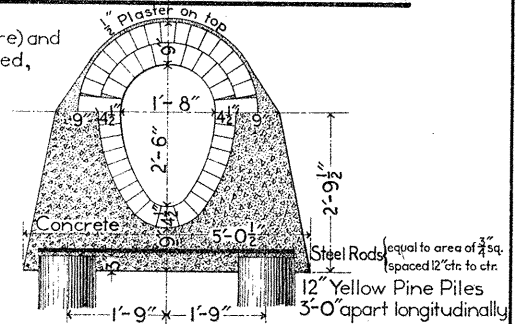

SECTION IN MAXIMUM CRADLE

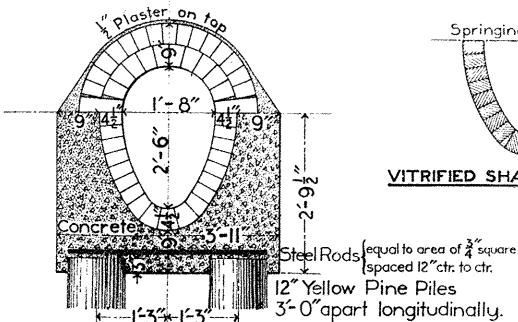

SECTION IN REDUCED CRADLE

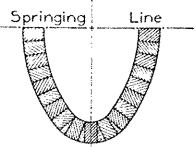

VITRIFIED SHALE BRICK INVERT.

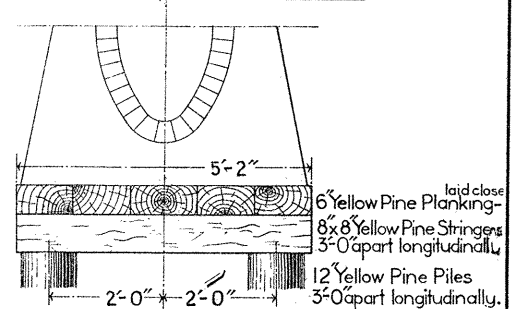

SECTION SHOWING PLATFORM AND PILES

GENERAL SECTIONS OF EGG-SHAPED SEWERS

DEPARTMENT OF PUBLIC WORKS
BUREAU OF SURVEYS
PHILADELPHIA
1906

W. H. H. H.
Chief Engineer

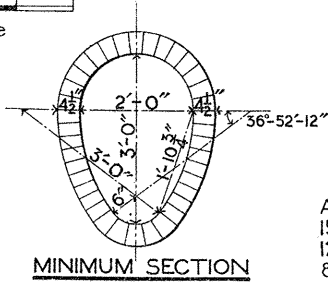
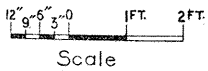

All Slants for Inlet Connections to be 15" dia. for No 1 and No 2 Inlets, 12" dia. for No 3 Inlets, and 8" dia. for No 4 Inlets.

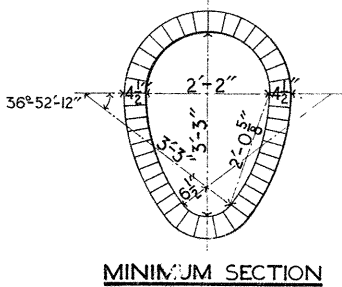
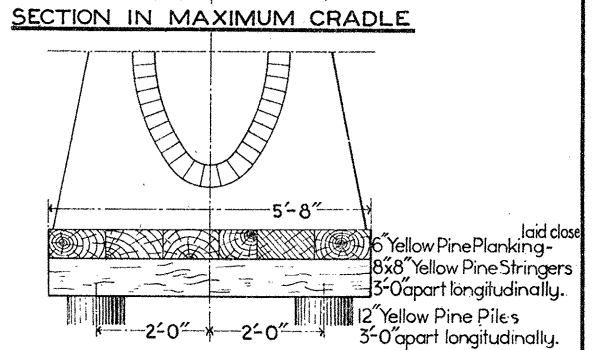
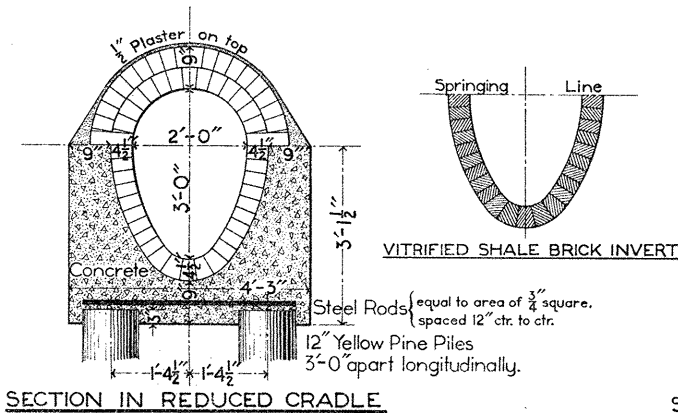
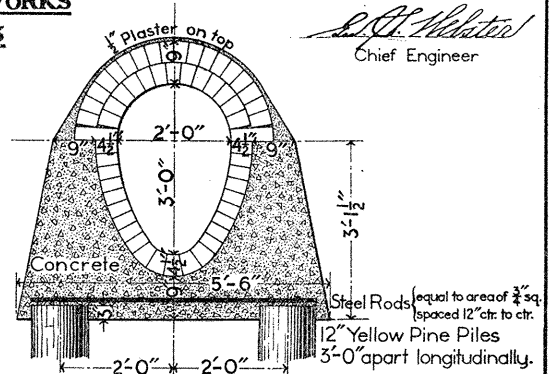

Steel Rods (equal to area of $\frac{3}{4}$ " square) and Piles, or Piles and Platform, if required, will be paid for at the price in the contract when ordered by the Chief Engineer.

Filling over top of Sewer to be at least 3 feet deep and with a slope not less than $\frac{1}{2}$ ft. horizontal over 1 ft. vertical, extending to the surface of the ground.

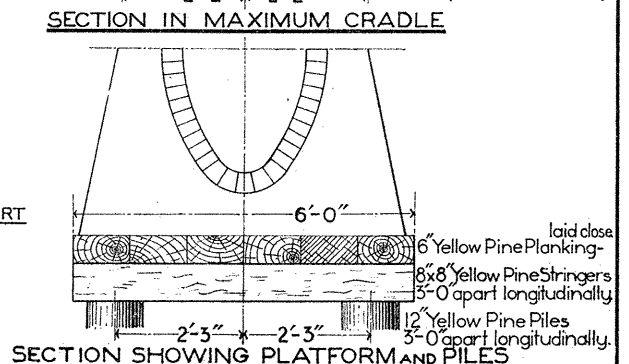
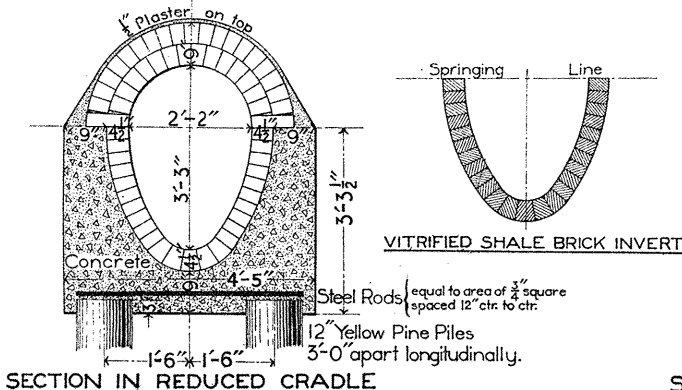
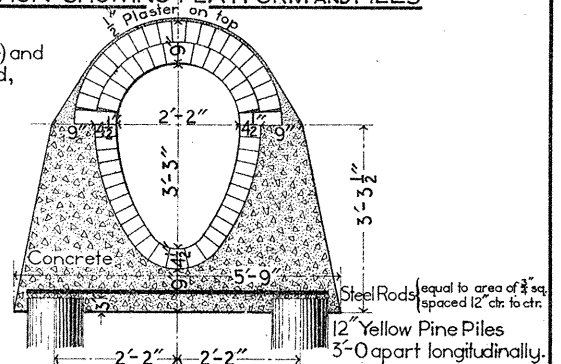

GENERAL SECTIONS OF EGG-SHAPED SEWERS

DEPARTMENT OF PUBLIC WORKS

BUREAU OF SURVEYS

PHILADELPHIA

1906

E. J. Albritton
Chief Engineer

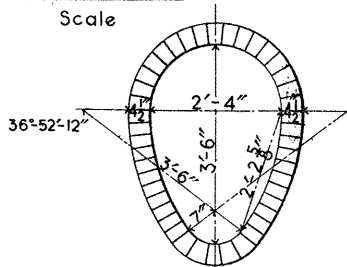
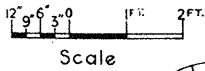

MINIMUM SECTION

All Slants for Inlet Connections to be 15" dia. for N^o 1 and N^o 2 Inlets, 12" dia. for N^o 3 Inlets, and 8" dia. for N^o 4 Inlets.

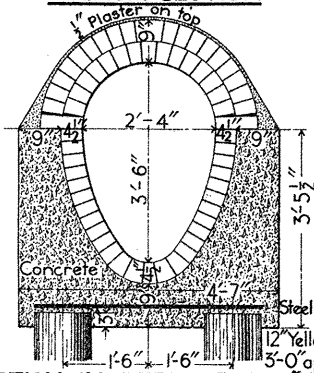

SECTION IN REDUCED CRADLE

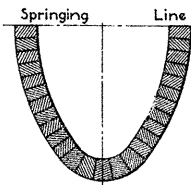

VITRIFIED SHALE BRICK INVERT.

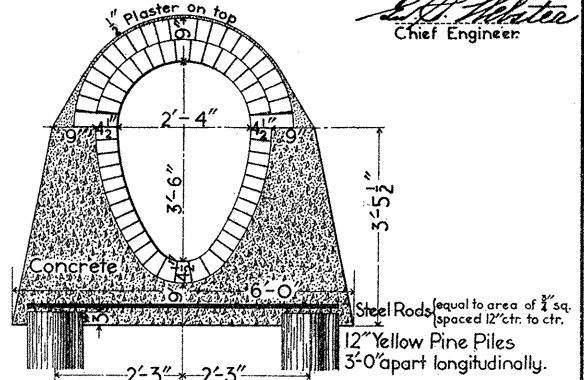

SECTION IN MAXIMUM CRADLE

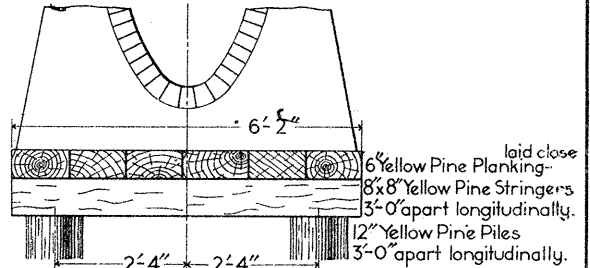

SECTION SHOWING PLATFORM AND PILES

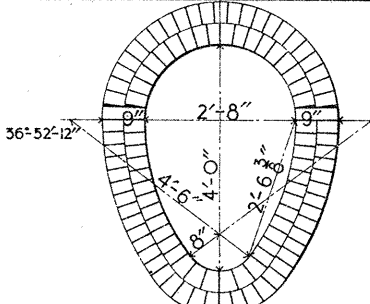

MINIMUM SECTION

Steel Rods (equal to area of $\frac{3}{4}$ " square) and Piles, or Piles and Platform, if required, will be paid for at the price in the contract when ordered by the Chief Engineer.

Filling over top of Sewer to be at least 3 feet deep and with a slope not less than $1\frac{1}{2}$ ft. horizontal over 1 ft. vertical, extending to the surface of the ground.

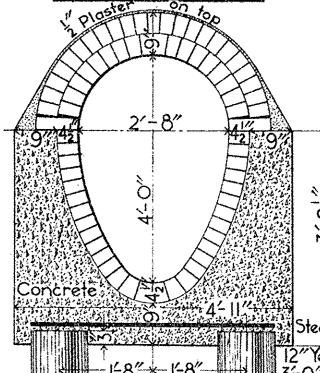

SECTION IN REDUCED CRADLE

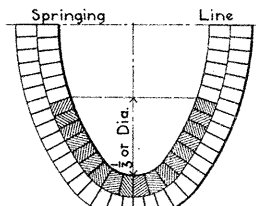

VITRIFIED SHALE BRICK INVERT

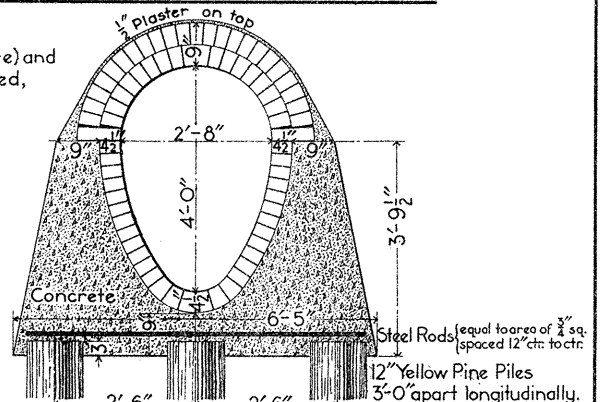

SECTION IN MAXIMUM CRADLE

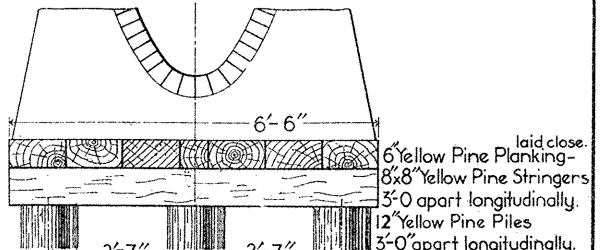

SECTION SHOWING PLATFORM AND PILES

GENERAL SECTIONS OF EGG-SHAPED SEWERS

DEPARTMENT OF PUBLIC WORKS
BUREAU OF SURVEYS

PHILADELPHIA

1906

S. H. Mather
Chief Engineer

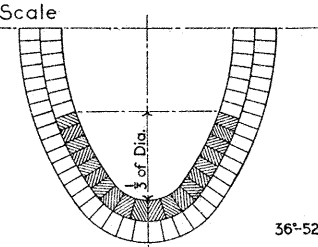
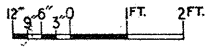

36°-52'-12"

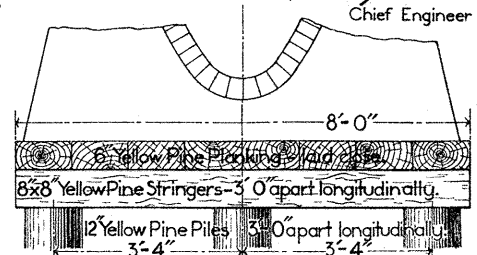
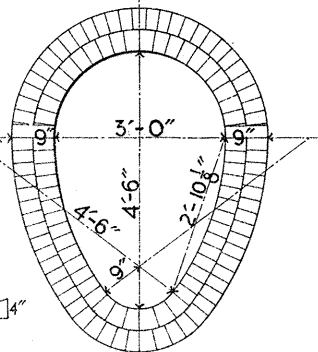

SECTION SHOWING PLATFORM AND PILES

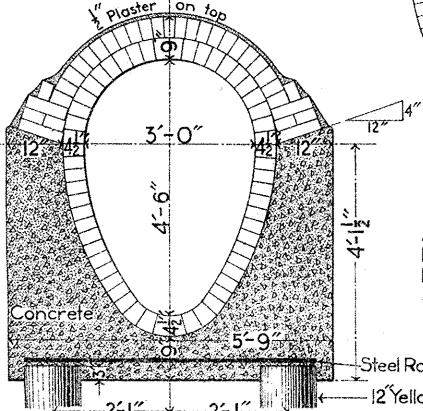

All Slants for Inlet Connections to be 15" dia. for N^o 1 and N^o 2 Inlets, 12" dia. for N^o 3 Inlets, and 8" dia. for N^o 4 Inlets.

Steel Rods-equal to area of 3/4 sq.- spaced 12" ctr. to ctr.

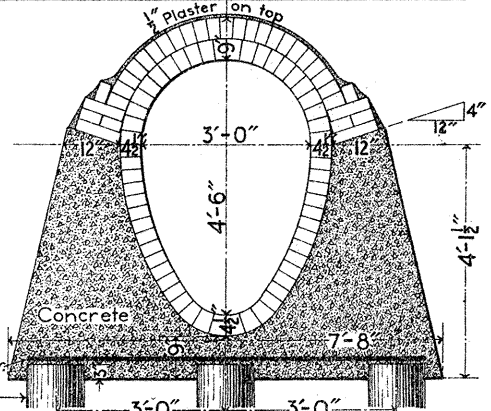

SECTION IN MAXIMUM CRADLE

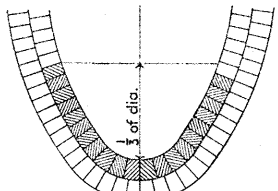

36°-52'-12"

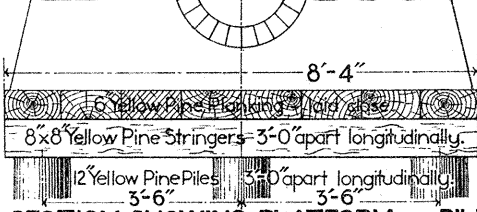
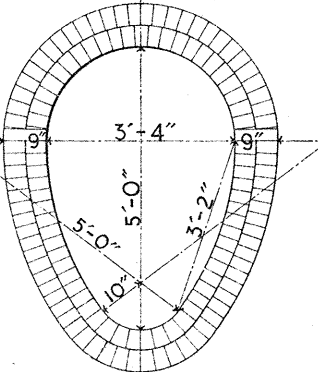

SECTION SHOWING PLATFORM AND PILES

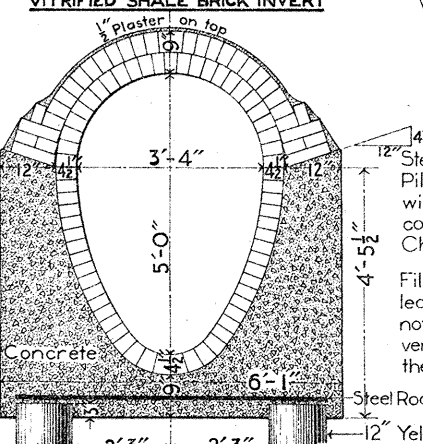

Steel Rods (equal to area of 3/4 square) and Piles, or Piles and Platform, if required, will be paid for at the price in the contract when ordered by the Chief Engineer.

Filling over top of Sewer to be at least 3 feet deep and with a slope not less than 1/2 ft. horizontal over 1 ft. vertical, extending to the surface of the ground.

Steel Rods-equal to area of 3/4 sq.- spaced 12" c. to c.

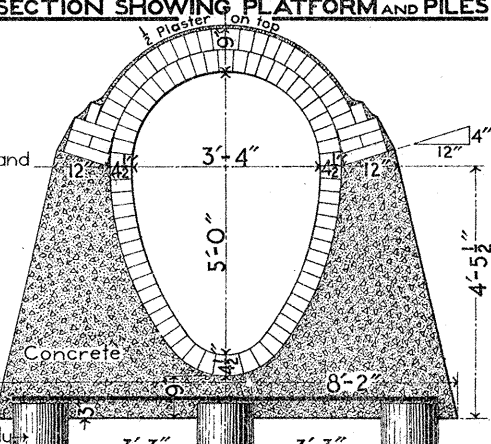

SECTION IN MAXIMUM CRADLE

GENERAL SECTIONS FOR SEPARATE SYSTEM

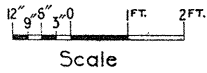

DEPARTMENT OF PUBLIC WORKS
BUREAU OF SURVEYS
PHILADELPHIA

D. H. Webster
Chief Engineer

1906

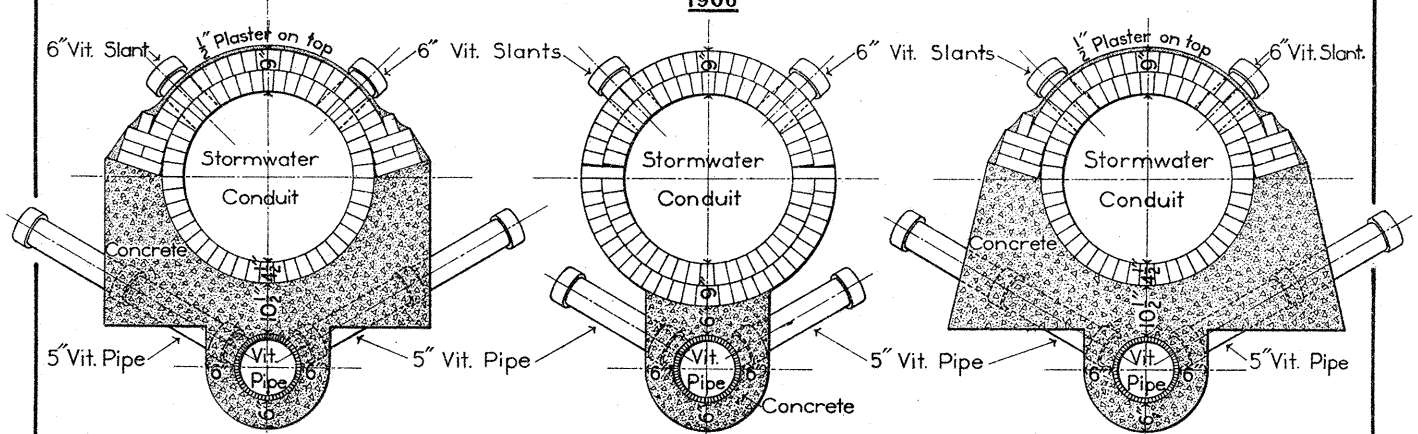

SECTION IN REDUCED CRADLE

MINIMUM SECTION

SECTION IN MAXIMUM CRADLE

RELATIVE POSITION FOR ALL CONDUITS OVER 2'-9" DIA.

6" dia. Vit. Slants for stormwater, and 5" dia. Vit. Slants and Pipes for house connections, as shown on sections, to be built every 15 feet, and included in price per linear foot of sewer.

All Slants for Inlet Connections to be 15" dia. for N^o 1 and N^o 2 Inlets, 12" dia. for N^o 3 Inlets, and 8" dia. for N^o 4 Inlets, to connect to stormwater conduit only.

The Cross Sections of the Separate System must conform in all respects to the General Details of Brick and Pipe Sewers.

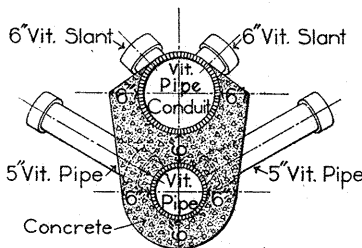

RELATIVE POSITION OF PIPE SEWERS

Concrete to be not less than 6" between outsides of Conduit and Pipe, but may be increased in special cases when required.

Concrete may be reduced in rock excavation only, as per specifications.

Filling over top of sewer to be at least 3 feet deep and with a slope not less than 1/2 ft. horizontal over 1 ft. vertical, extending to the surface of the ground.

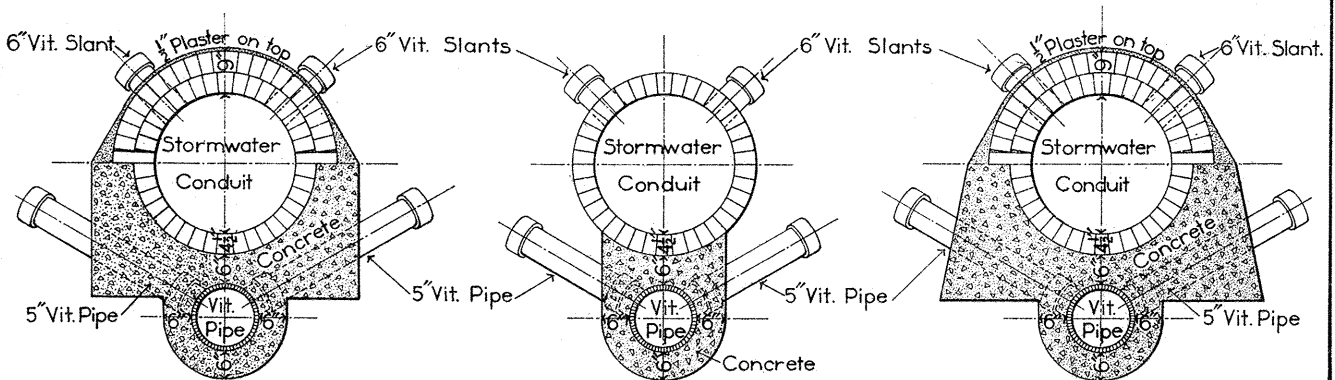

SECTION IN REDUCED CRADLE

MINIMUM SECTION

SECTION IN MAXIMUM CRADLE

RELATIVE POSITION FOR ALL CONDUITS UNDER 3'-0" DIA.

MANHOLE AND GENERAL DETAILS FOR VIT. PIPE SEWERS

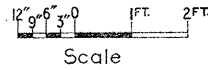

DEPARTMENT OF PUBLIC WORKS
BUREAU OF SURVEYS
PHILADELPHIA

E. S. Abbot
Chief Engineer

1906

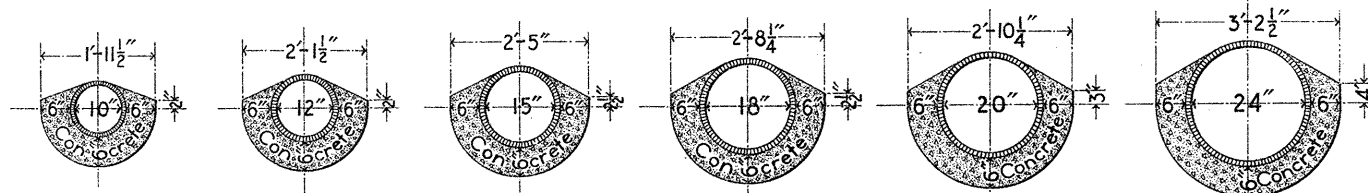

CROSS SECTIONS FOR VITRIFIED PIPES

All Slants for Inlet Connections to be 15" dia. for N^o 1 and N^o 2 Inlets, 12" dia. for N^o 3 Inlets, and 8" dia. for N^o 4 Inlets.

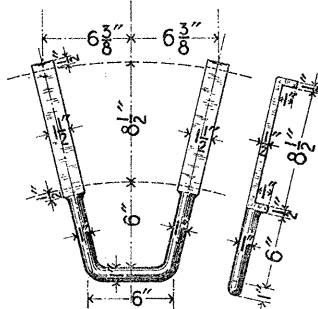
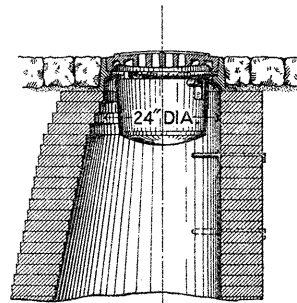

5" dia. Slants for House Connections to be not less than 15 ft. apart on each side by means of single Y's.

Filling over top of Sewer to be at least 3 ft. deep and with a slope not less than 1/2 ft. horizontal over 1 ft. vertical, extending to the surface of the ground.

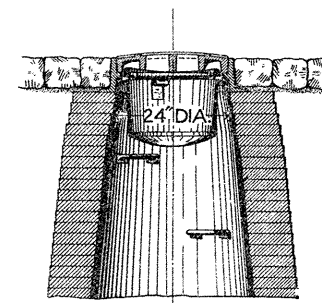

GALVANIZED WROUGHT-IRON STEPS FOR MANHOLES

To be not more than 18" apart.

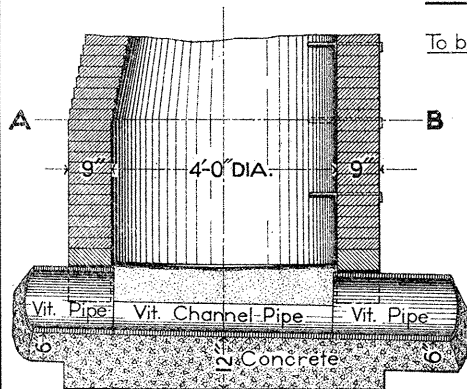

SECTION C-D

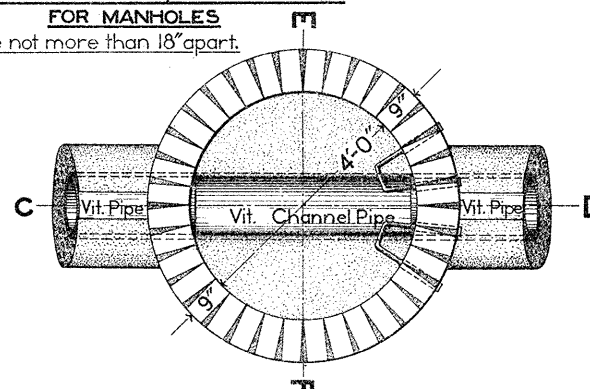

PLAN A-B

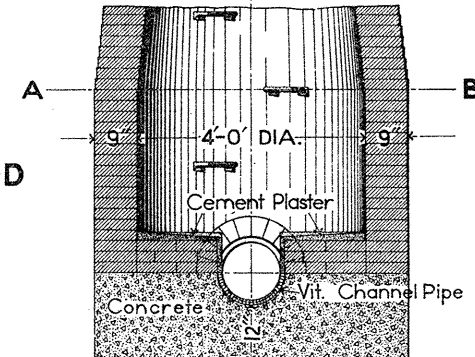

SECTION E-F

DETAILS OF MANHOLE FOR VITRIFIED PIPES

MANHOLE FOR JUNCTIONS

DEPARTMENT OF PUBLIC WORKS
BUREAU OF SURVEYS
PHILADELPHIA
1906

S. C. Webster
Chief Engineer

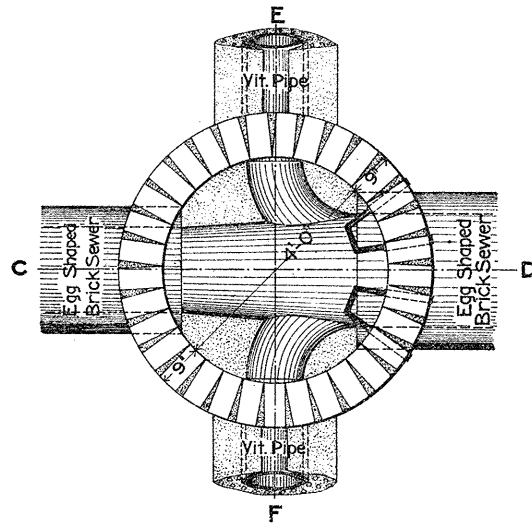
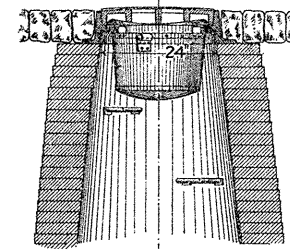
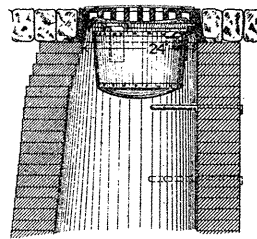
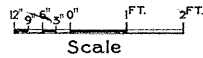

PLAN A-B

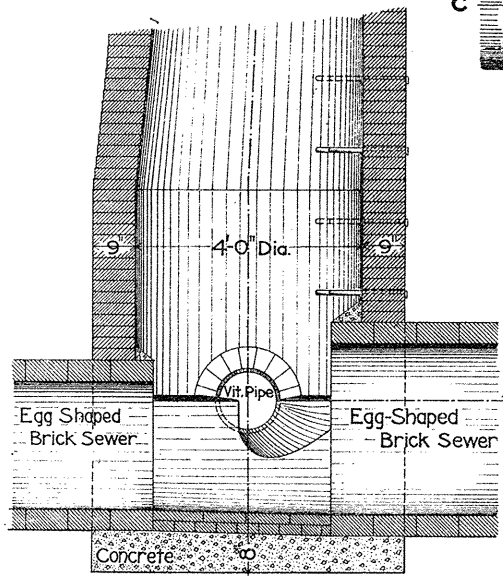

SECTION C-D

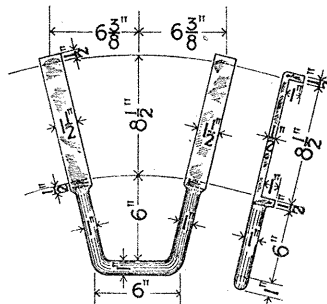

GALVANIZED WROUGHT-IRON STEPS
FOR MANHOLES

To be not more than 18' apart

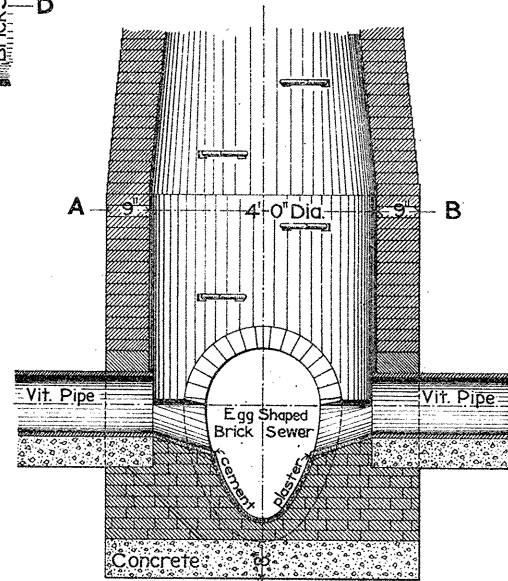

SECTION E-F

General Details for Egg-shaped Sewers, City of Philadelphia.

DEPT. OF PUBLIC WORKS,
BUREAU OF SURVEYS,
FEB. 1905.
Revised Jan. 1903

E. C. Mott
CHIEF ENGINEER.



Manholes
for

Egg-shaped Sewers 16"x23" to 24"x36"

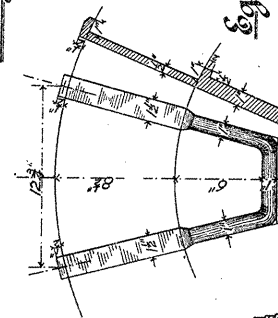

M wrought-iron Steps
To be Galvanized

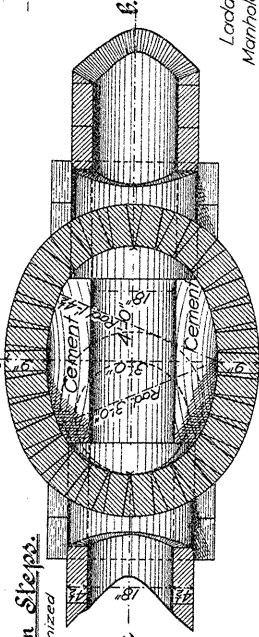

Plan m-n.

M wrought-iron Ladder Bars
To be Galvanized

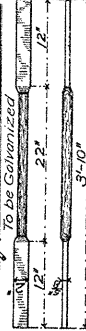

Section a-k.

Foundation of concrete under brickwork where directed

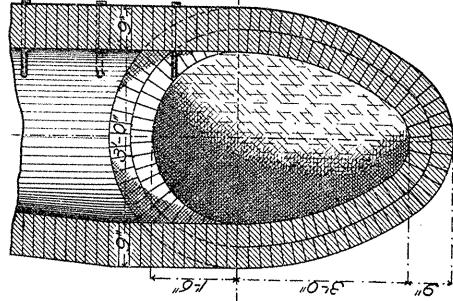

Section c-d.

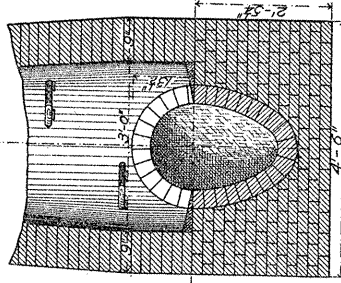

Section c-d.

Ladder Bars to be used where
Manhole is less than 3ft. in diam.

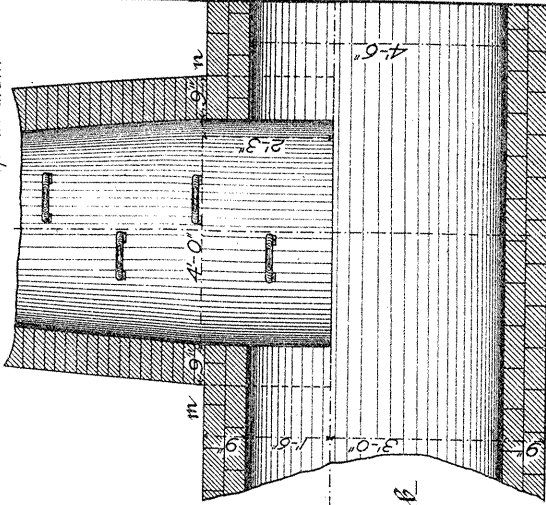

Section a-f.

Foundation of concrete under brickwork where directed

Manholes for Egg-shaped Sewers

Plan n-n.

Chas. F. Mott

STANDARD WELLHOLE DETAILS

DEPARTMENT OF PUBLIC WORKS

BUREAU OF SURVEYS

PHILADELPHIA

1906

E. S. Whitton
Chief Engineer.

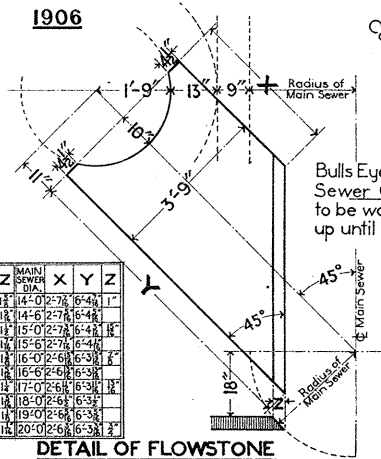
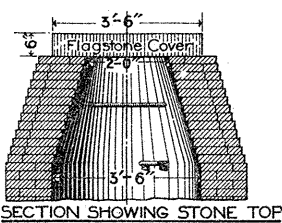
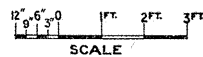
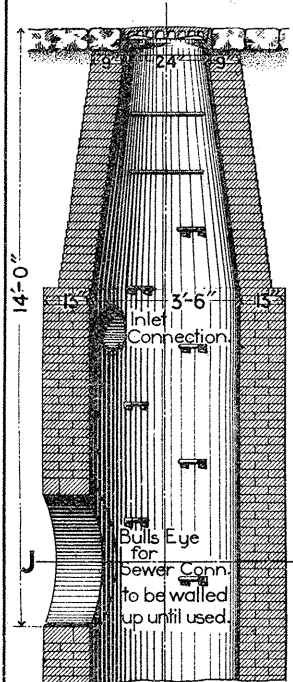

MAIN SEWER DIA.	X			Y			Z			MAIN SEWER DIA.	X			Y			Z							
	1	2	3	1	2	3	1	2	3		1	2	3	1	2	3	1	2	3					
4'-0"	13	11	7	7	6	8	6	9	0	2	4	0	6	6	6	1	1	4	0	2	7	6	4	1
4'-6"	13	11	7	7	6	8	6	9	0	2	4	0	6	6	6	1	1	4	0	2	7	6	4	1
5'-0"	13	11	7	7	6	8	6	9	0	2	4	0	6	6	6	1	1	4	0	2	7	6	4	1
5'-6"	13	11	7	7	6	8	6	9	0	2	4	0	6	6	6	1	1	4	0	2	7	6	4	1
6'-0"	13	11	7	7	6	8	6	9	0	2	4	0	6	6	6	1	1	4	0	2	7	6	4	1
6'-6"	13	11	7	7	6	8	6	9	0	2	4	0	6	6	6	1	1	4	0	2	7	6	4	1
7'-0"	13	11	7	7	6	8	6	9	0	2	4	0	6	6	6	1	1	4	0	2	7	6	4	1
7'-6"	13	11	7	7	6	8	6	9	0	2	4	0	6	6	6	1	1	4	0	2	7	6	4	1
8'-0"	13	11	7	7	6	8	6	9	0	2	4	0	6	6	6	1	1	4	0	2	7	6	4	1
8'-6"	13	11	7	7	6	8	6	9	0	2	4	0	6	6	6	1	1	4	0	2	7	6	4	1

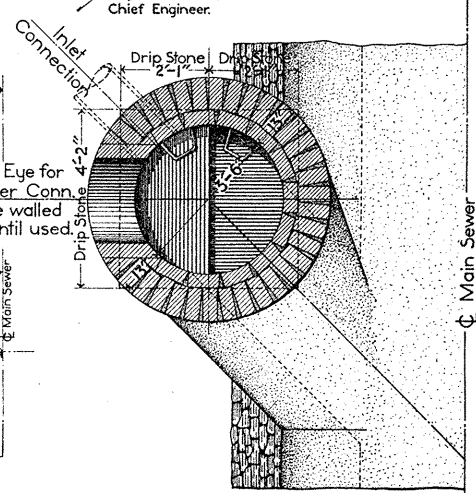

PLAN SECTION ON J-K

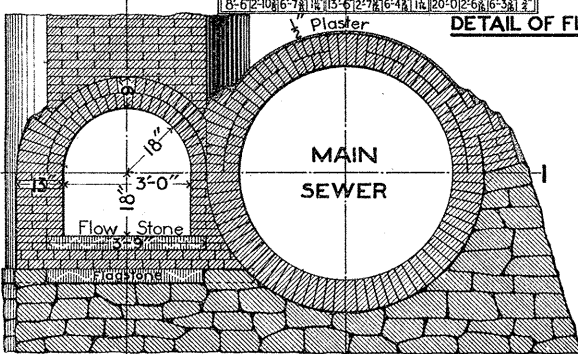
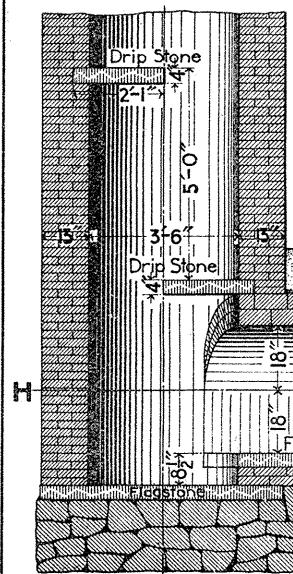

SECTION ON E-F-G

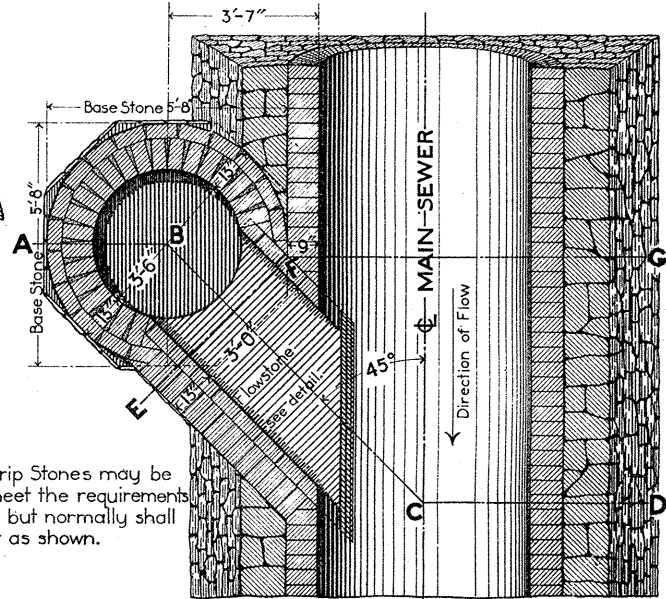

PLAN SECTION ON H-I

NOTE
Location of Drip Stones may be adjusted to meet the requirements of each case, but normally shall be 5'-0" apart as shown.

CAST IRON MANHOLE COVER.

AND FRAME

DEPT. OF PUBLIC WORKS.
BUREAU OF SURVEYS.
JAN. 1903.

E. H. Whitton
CHIEF ENGINEER.

SCALE 0 1 2 3 4 5 6 INCHES

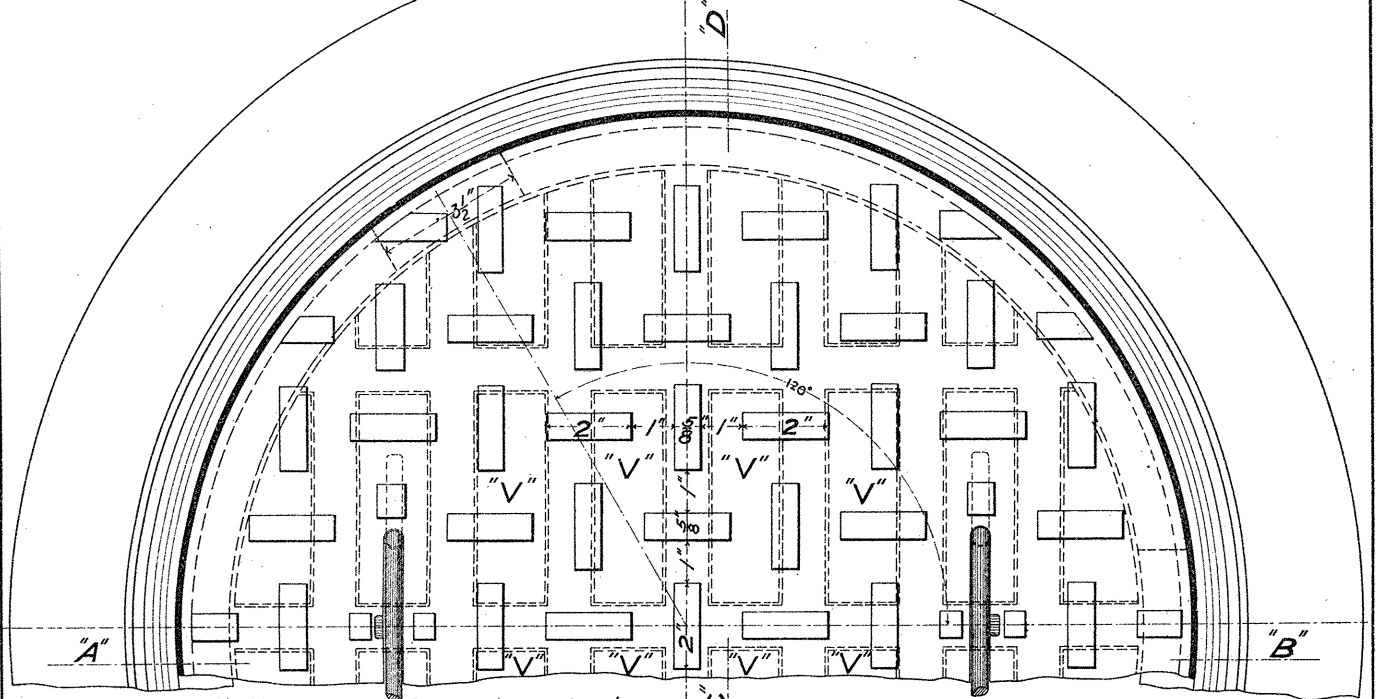

Note: For Ventilating Covers, 8 openings as shown by dotted Lines at points marked "V"

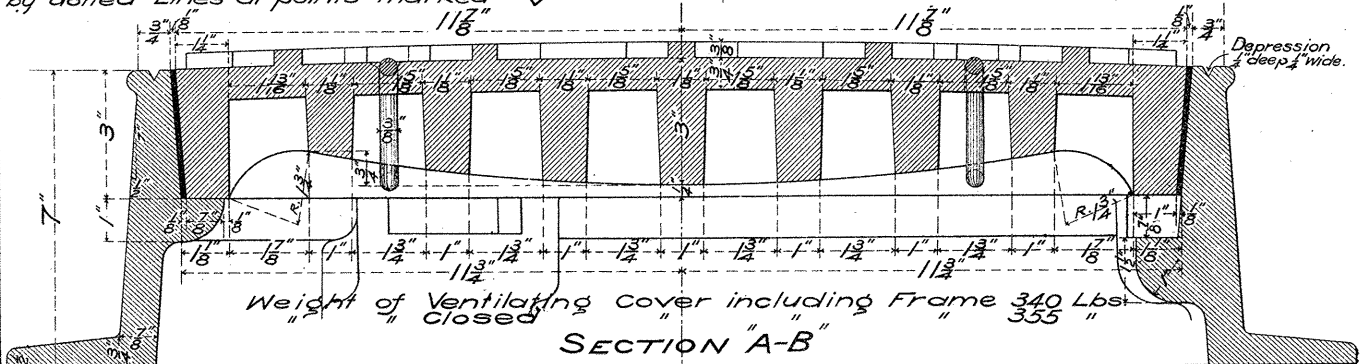

SECTION "A-B"

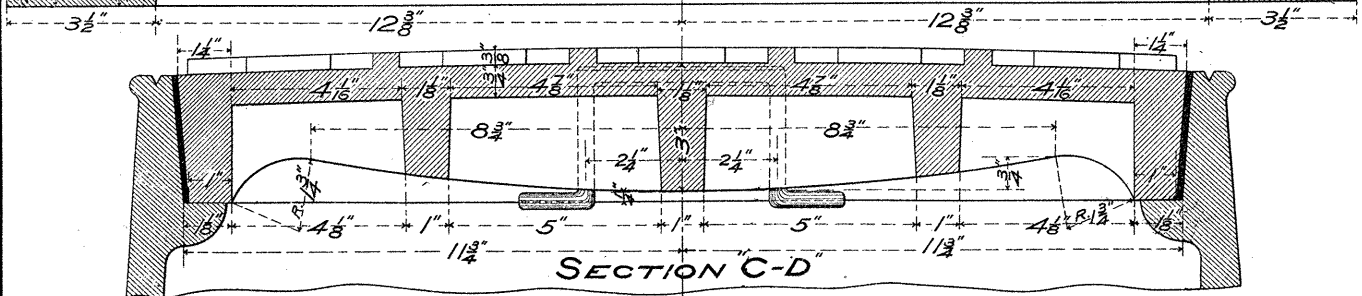

SECTION "C-D"

ASPHALTUM FILLED CAST IRON MANHOLE COVERS AND FRAMES

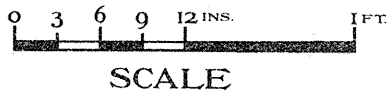

DEPARTMENT OF PUBLIC WORKS
BUREAU OF SURVEYS
JANUARY 1900

E. H. Habicht
CHIEF ENGINEER

SECTION A-B-C

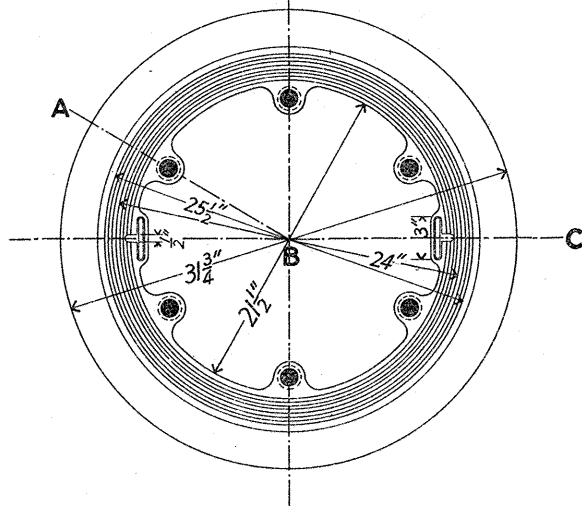
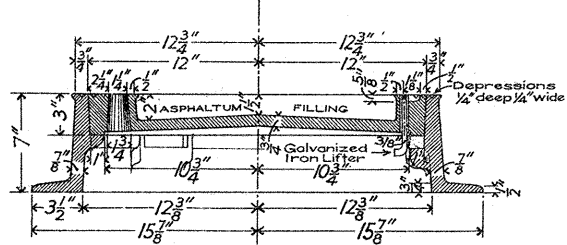

VENTILATING COVER AND FRAME

SECTION A-B-C

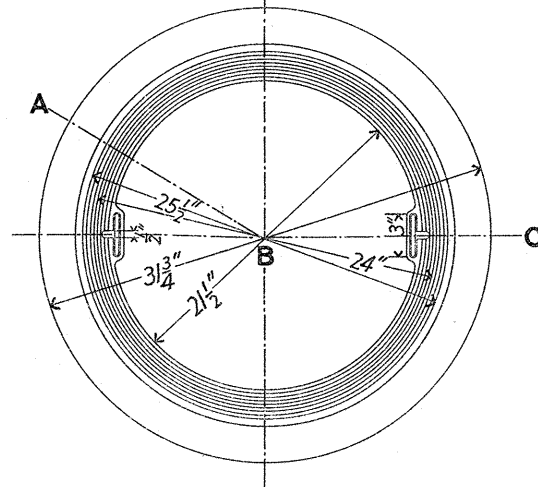
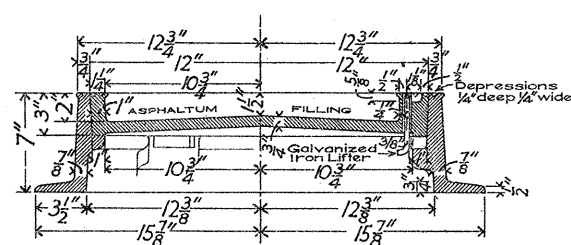

CLOSED COVER AND FRAME

STANDARD MANHOLE BUCKET

DEPT. OF PUBLIC WORKS
BUREAU OF SURVEYS
APRIL—1905

E. C. Mather
CHIEF ENGINEER

SCALE: 0 1 2 3 4 INCHES

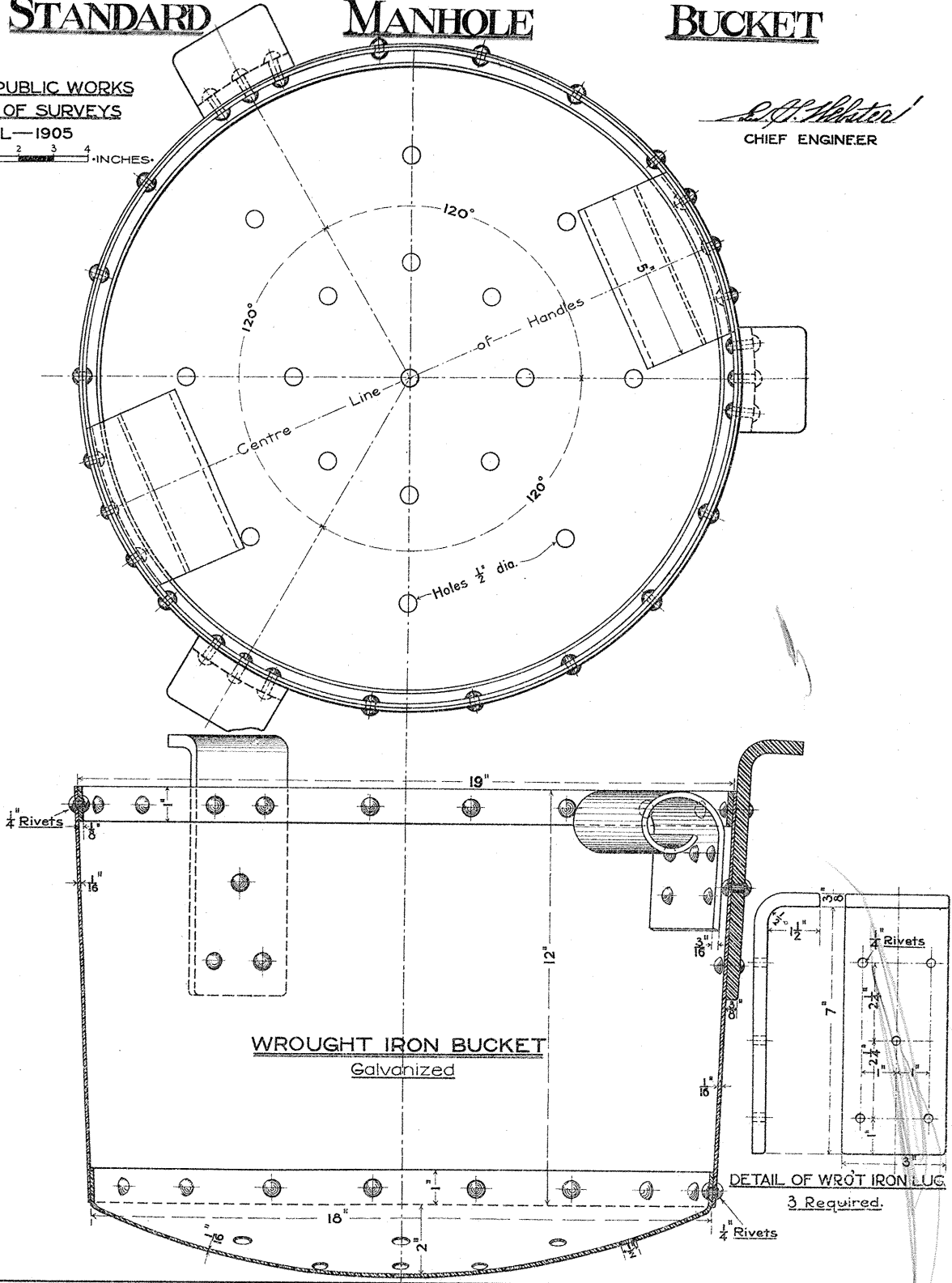

No. 1. OPEN MOUTH BRICK AND STONE INLET.

Dept. of Public Works Bureau of Surveys

Phila. Jan. 1899.
Revised Jan. 1903.

E. S. Hildner.
Chief Engineer

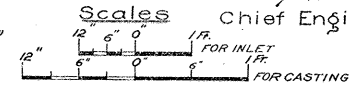
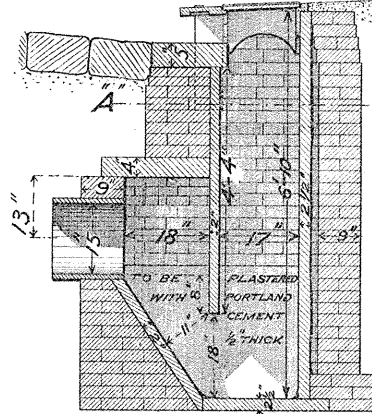

BILL OF FLAGGING FOR INLET

Drip Stone	1'-4" x 5'-8" x 5"
Trap	4'-4" x 5'-4" x 2"
Back	6'-10" x 5'-4" x 2 1/2"
Cover	2'-0" x 5'-4" x 4"
Inclined	2'-10" x 5'-4" x 2"
Bottom	2'-3 3/4" x 5'-4" x 2 1/2"

WEIGHT OF CASTINGS
FOR STRAIGHT CURB 650 LBS
FOR CURVED CURB 630 LBS

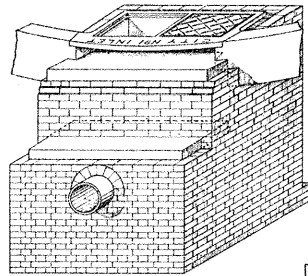

ISOMETRICAL VIEW

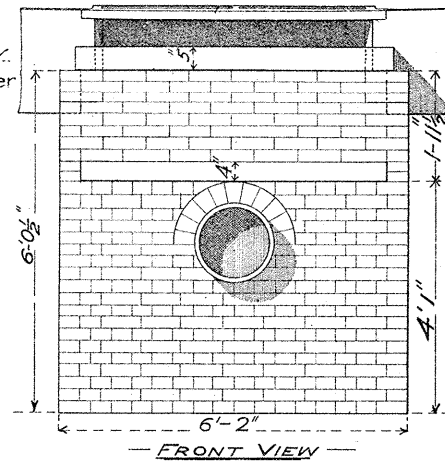

FRONT VIEW

GENERAL NOTES

All Brickwork to be laid in Portland Cement Mortar.
Foundation of Inlet to be of Rubble Masonry, Timber or Concrete as directed.

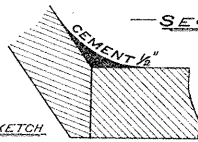

SKETCH
SHOWING MANNER OF
JOINING INCLINED WITH
BOTTOM STONES

SECTION "A-B"

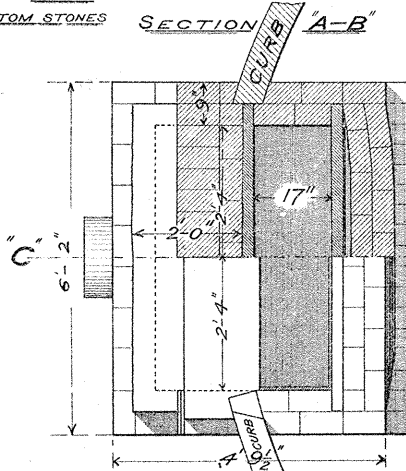

TOP VIEW
WITHOUT CASTING

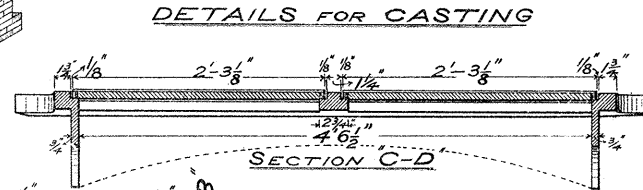

DETAILS FOR CASTING

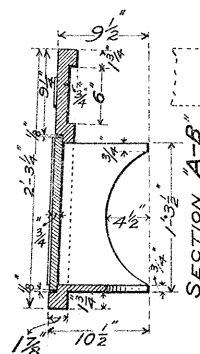

SECTION "A-B"

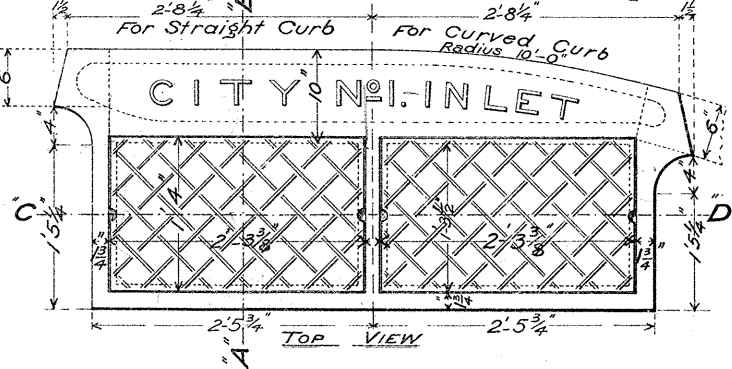

TOP VIEW

No 2 & 3. OPEN MOUTH BRICK AND STONE INLETS

Dept of Public Works Bureau of Surveys

Phila. Jan. 1899.
Revised Jan. 1903.

L. H. Hobbes
Chief Engineer

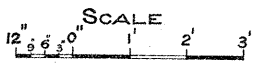
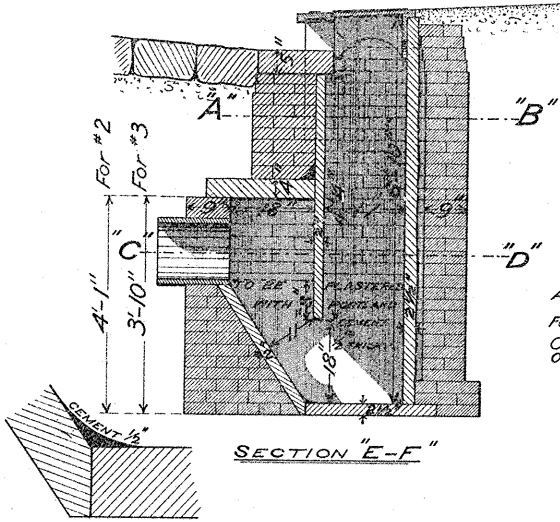

GENERAL NOTES

All Brickwork to be laid in Portland Cement Mortar.
Foundation of Inlet to be of Rubble Masonry, Timber or Concrete, as directed.
Outlet Pipe for No 2 Inlets 15" dia.
" " " " 3 " " 12 "

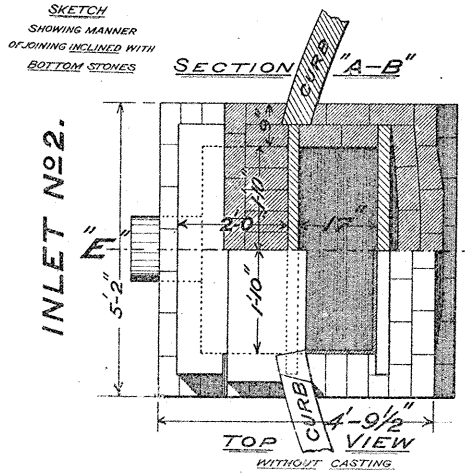
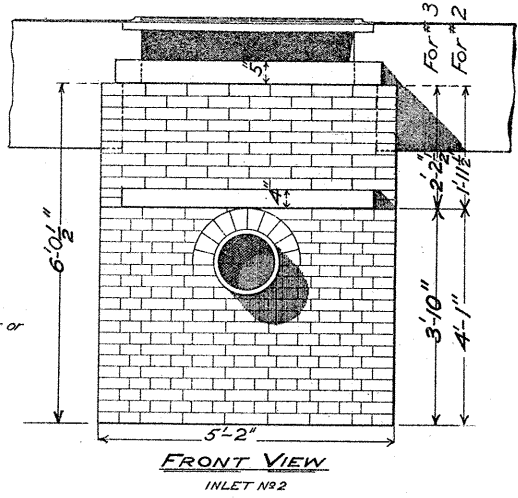
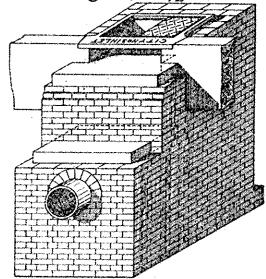

BILL of FLAGGING FOR INLET No 2.

Drip Stone	1'-4" x 3'-8" x 5"
Trap	4'-4" x 4'-4" x 2"
Back	6'-10" x 4'-4" x 2 1/2"
Cover	2'-0" x 4'-4" x 4"
Inclined	2'-10" x 4'-4" x 2"
Bottom	2'-3" x 4'-4" x 2 1/2"

BILL of FLAGGING FOR INLET No 3.

Drip Stone	1'-4" x 3'-8" x 5"
Trap	4'-4" x 3'-4" x 2"
Back	6'-10" x 3'-4" x 2 1/2"
Cover	2'-0" x 3'-4" x 4"
Inclined	2'-10" x 3'-4" x 2"
Bottom	2'-3" x 3'-4" x 2 1/2"

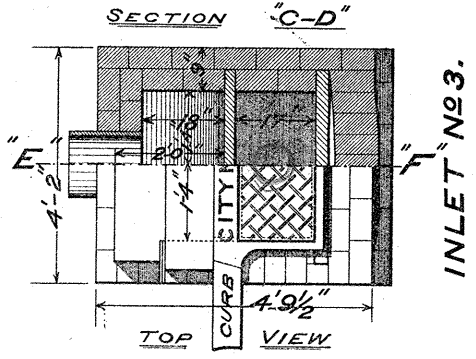

№ 4 OPEN MOUTH BRICK AND STONE INLET.

—Dept of Public Works— Bureau of Surveys—

Phila Jan 1897

Revised Jan 1903

E. J. H. H. H.

Chief Engineer

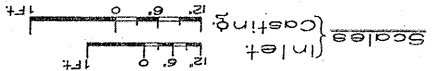

—GENERAL NOTES—

- All Brickwork to be Laid in Portland Cement Mortar
- All Brickwork inside of Inlet to be Plastered with Portland Cement Mortar
- Foundation of Inlet to be Rubble Masonry, Timbers or Concrete when directed.

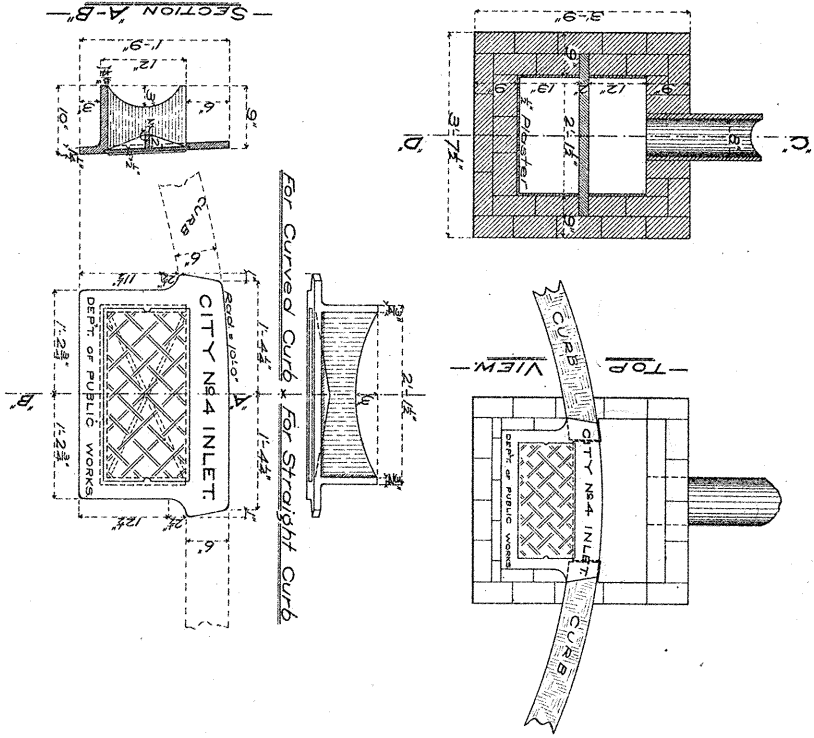

DETAILS FOR CASTING

BILL OF MATERIALS FOR INLET	
TRG Stone	21' x 21.5' x 21.0'
Bottom "	2' x 21.0' x 31.75'
Facing "	2' x 21.5' x 21.0'
C.P.P. "	3' x 11.3' x 21.0'
Cover "	21' x 11.44' x 21.0'

WEIGHT OF CASTINGS
Straight Curb 230 Lbs
CURVED " 225 "

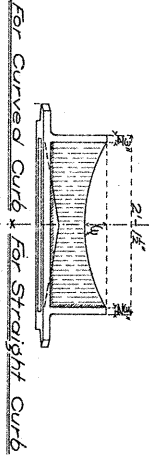
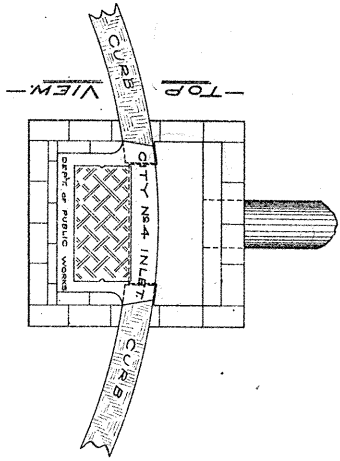
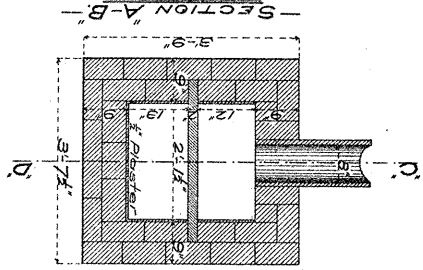
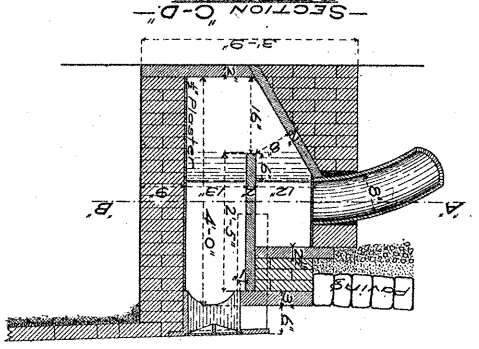
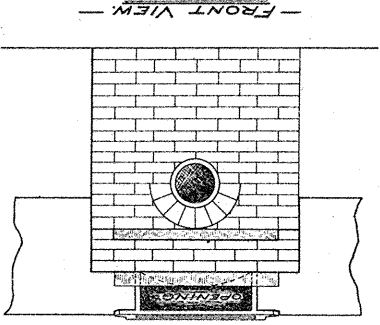

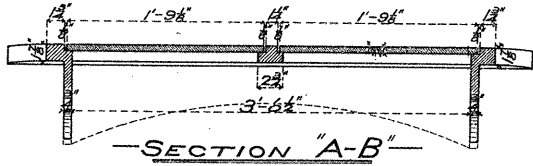

WEIGHTS OF CASTINGS

No 2	Curved Curb	485 Lbs.
	Straight	495 "
No 3	Curved	340 "
	Straight	345 "

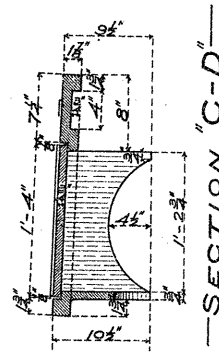
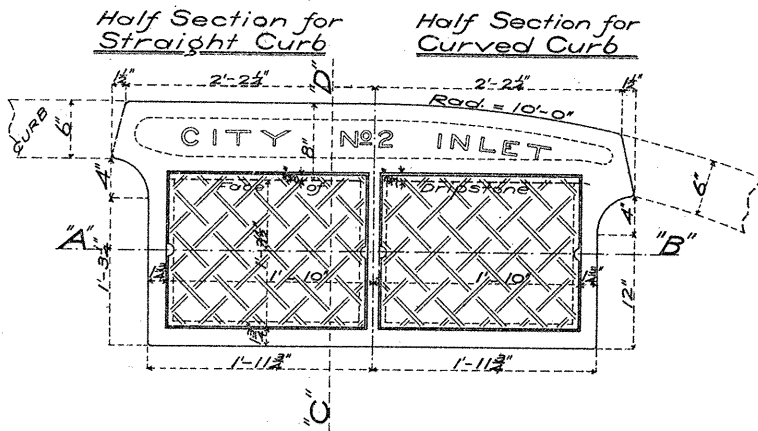

**DETAILS OF CASTINGS
FOR
No 2 AND No 3
OPEN MOUTH INLETS**

—Dept. of Public Works—Bureau of Surveys—
—Phila. Jan. 1897—
W. H. Water
Chief Engineer

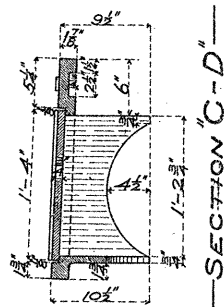
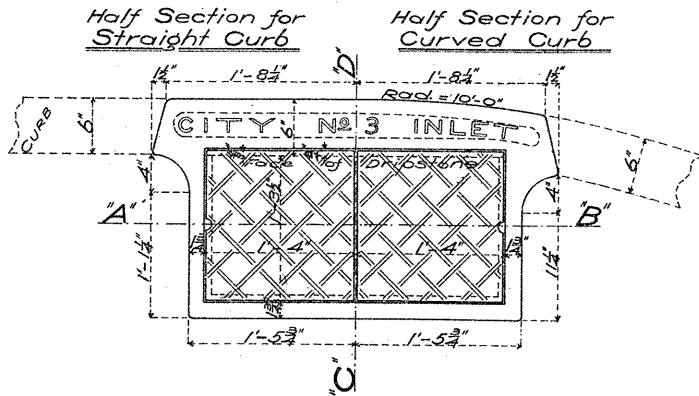
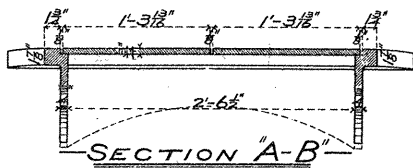

No. 1, 2 & 3. GRATE TOP BRICK AND STONE INLETS.

Dept of Public Works Bureau of Surveys
Phila. Jan. 1899

S. S. Whitton
Chief Engineer

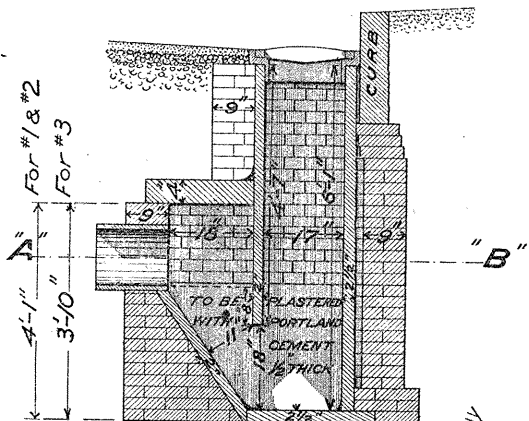

BILL OF FLAGGING FOR INLET No. 1.

Trap Stone	4'-7" x 5'-4" x 2"
Back "	6'-1" x 5'-4" x 2 1/2"
Cover "	2'-0" x 5'-4" x 4"
Inclined "	2'-10" x 5'-4" x 2"
Bottom "	2'-3" x 5'-4" x 2 1/2"

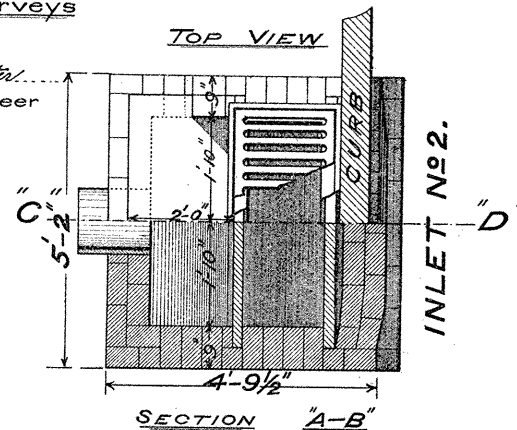

SECTION "A-B"

GENERAL NOTES

All Brickwork to be laid in Portland Cement Mortar.
Foundation of Inlet to be of Rubble Masonry, Timber or Concrete as directed.
Outlet Pipe for Nos. 1 & 2 Inlets 15" dia.
" " " " 3 " 12" "

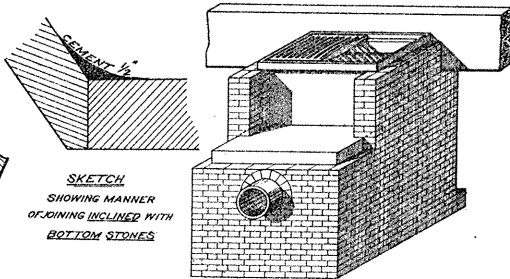

ISOMETRICAL VIEW

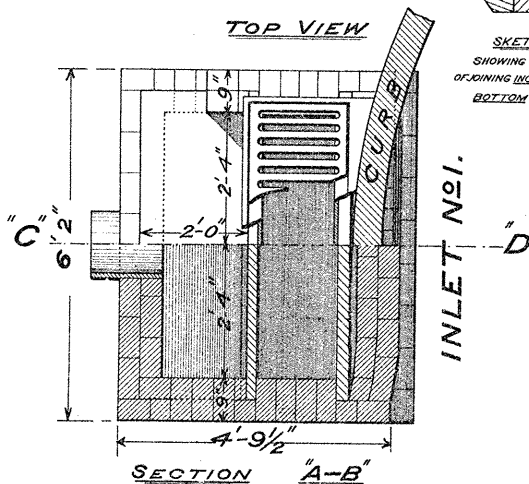

BILL OF FLAGGING FOR INLET No. 2.

Trap Stone	4'-7" x 4'-4" x 2"
Back "	6'-1" x 4'-4" x 2 1/2"
Cover "	2'-0" x 4'-4" x 4"
Inclined "	2'-10" x 4'-4" x 2"
Bottom "	2'-3" x 4'-4" x 2 1/2"

BILL OF FLAGGING FOR INLET No. 3.

Trap Stone	4'-7" x 3'-4" x 2"
Back "	6'-1" x 3'-4" x 2 1/2"
Cover "	2'-0" x 3'-4" x 4"
Inclined "	2'-10" x 3'-4" x 2"
Bottom "	2'-3" x 3'-4" x 2 1/2"

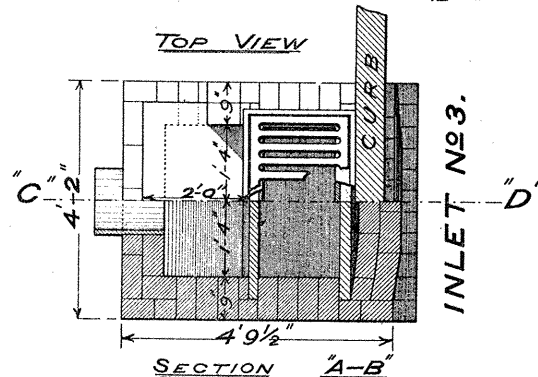

SECTION "A-B"

No. 4 GRATE TOP BRICK AND STONE INLET

— Dept. of Public Works — — Bureau of Surveys —
— Phila. Jan. 1897. —

S. S. Webster
Chief Engineer

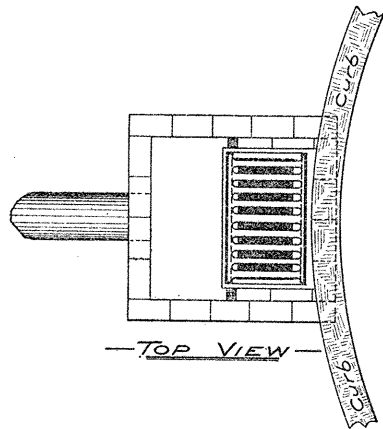

— TOP VIEW —

DETAILS OF CASTING

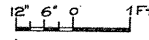
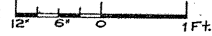
Scales { Inlet 
Casting 

— For —
Curved Curb * Straight Curb

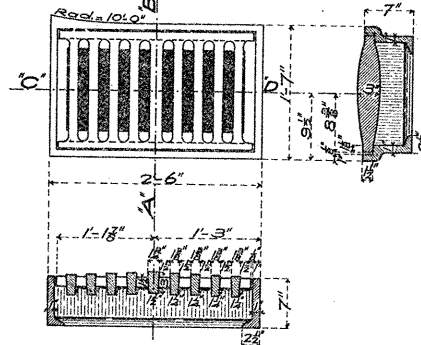

SECTION "A-B"

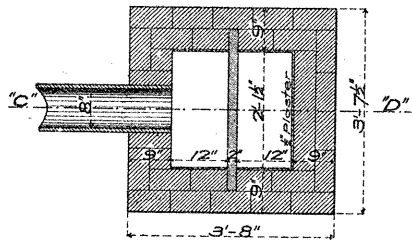

— SECTION "A-B" —

— SECTION "C-D" —

— GENERAL NOTES —

All Brickwork to be Laid in Portland Cement Mortar.

All Brickwork inside of Inlet to be Plastered with Portland Cement Mortar.

Foundation of Inlet to be Rubble Masonry, Timber, or Concrete when directed.

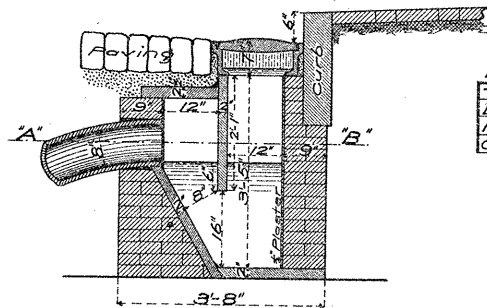

— SECTION "C-D" —

BILL OF FLAGGING FOR INLET.	
Trap Stone	2" x 2-1" x 2-10"
Bottom "	2" x 2-0" x 3-7 1/2"
Inclined "	2" x 2-5" x 2-10"
Cover "	2 1/2" x 1-4 1/2" x 2-10"

WEIGHT OF GRATING
INCLUDING FRAME
315 LBS.

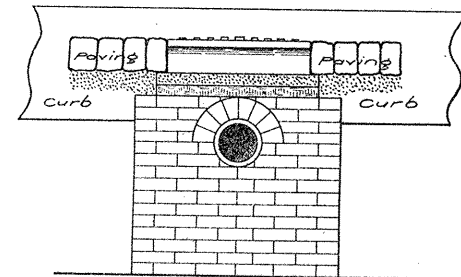

— FRONT VIEW. —

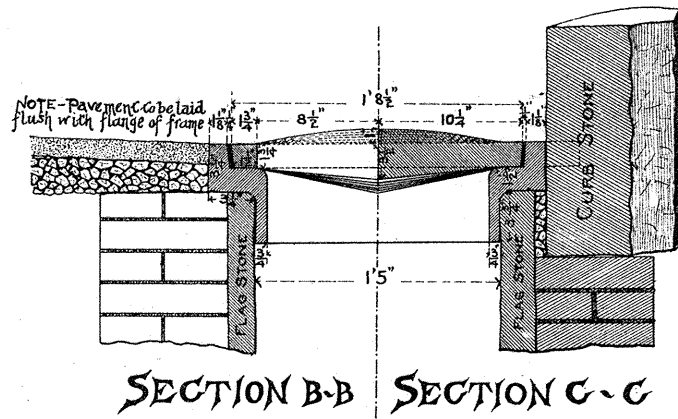
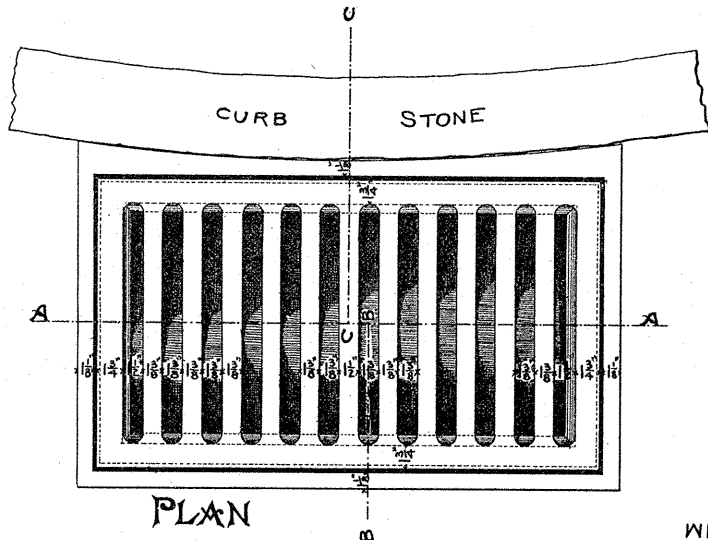

WEIGHT OF GRATING INCLUDING FRAME COMPLETE 490 LBS.

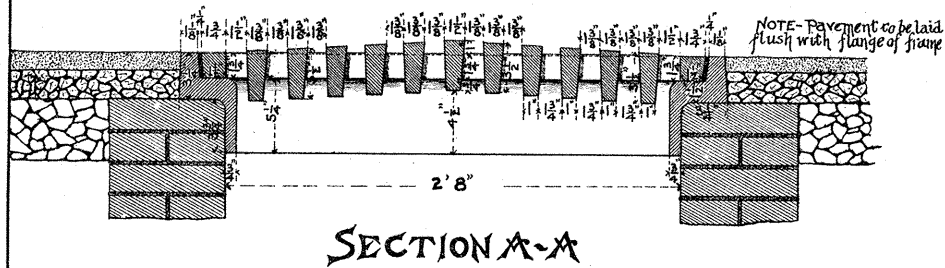

DESIGN FOR GRATE TOP
BRICK & STONE INLET
No 3

DEPT. OF PUBLIC WORKS
BUREAU OF SURVEYS
PHILADELPHIA

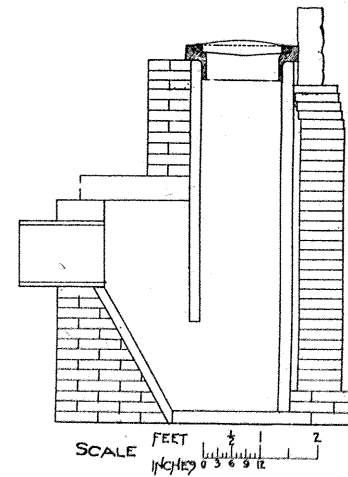

SCALE FEET
INCHES 0 1 2 3 4 5 6 7 8 9 10 11 12

DECEMBER 1893

E. P. Hobbs
CHIEF ENGINEER

COUNTRY ROAD INLET No.3B.

Dept. of Public Works Bureau of Surveys
Phila. July 1904.

E. D. Webster
Chief Engineer

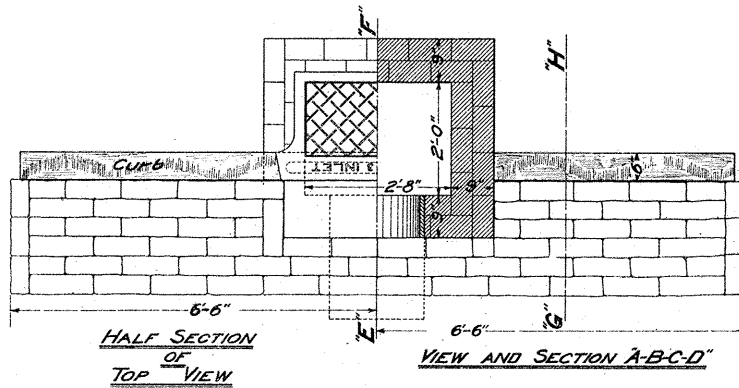

GENERAL NOTES

All Brickwork to be Laid in Portland Cement Mortar.

Foundation of Inlet to be Rubble Masonry, or Concrete when directed.

The Casting shall be that of a Standard No.3 Open Mouth Inlet.

The price for Inlet shall include a Belgian Block Gutter, on Concrete Base, for a distance of least 6'-6" on each side from the centre line of the Inlet, as shown.

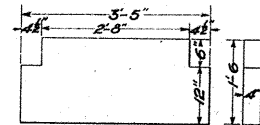
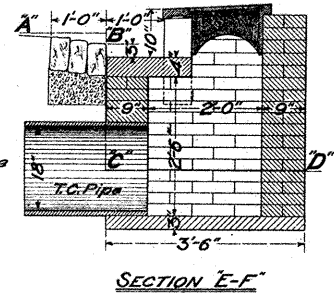

BILL OF FLAGGING FOR INLET

Drip Stone	4 x 1'-6" x 3'-5"
Bottom "	3 x 3'-6" x 4'-2"

