

1985

STANDARDS DETAILS  
and  
STANDARD SPECIFICATIONS  
for  
SEWERS



City of Philadelphia

WATER DEPARTMENT

# CONTENTS

TITLE	PAGE
<b>STANDARD DETAILS FOR SEWERS</b>	
Vitrified Clay Pipe Sewer . . . . .	1
R.C. Pipe Sewer and Stormwater Conduit . . . . .	2
Vit. Clay Pipe Sewer with R.C. Pipe SW. Conduit . . . . .	3
Circular Brick Sewer . . . . .	4
Egg-Shaped Brick Sewer . . . . .	5
Laterals Separate System . . . . .	6
Saddle Connection to Brick or R.C. Pipe Sewers . . . . .	7
Stormwater Turnout for Separate System . . . . .	8
Concrete Collars at Connections . . . . .	9
Embankment Over Pipes . . . . .	10
Pipe Endwall . . . . .	11
Pipe Headwall . . . . .	12
Chain Link Fence . . . . .	13
Brick Manhole: Riser and Cone . . . . .	14
Precast Concrete Manhole: Riser and Cone . . . . .	15
Concrete Manhole Base: 30" Dia. and Under . . . . .	16
Precast Concrete Manhole Bases: Pipe 30" Dia. and Under; Junction Manhole — Pipe 30" Dia. and Under . . . . .	17
Concrete Manhole Base: 36" Dia. and Over . . . . .	18
Concrete Manhole Base: SW. Manhole — 30" Dia. and Under . . . . .	19
Concrete Manhole Base: SW. Manhole — 36" Dia. and Over . . . . .	20
Concrete Manhole Base: Junction Manhole . . . . .	21
Brick or Concrete Manhole Base: Summit Manhole . . . . .	22
Precast Concrete Drop Manhole . . . . .	23
Wellhole . . . . .	24
Wellhole . . . . .	25
Gray Iron Manhole Frame & Covers . . . . .	26
Gray Iron Manhole Frame & Covers . . . . .	27
Manhole Steps and Ladder Bar . . . . .	28
Assembly of Precast Inlets: Open Mouth Grate; Open Mouth; Highway Grate . . . . .	29
Precast Catch Basin: With Welded Wire Fabric . . . . .	30
Precast Catch Basin: With Reinforcing Bars . . . . .	31
Precast Reinforced Concrete Inlet Hood . . . . .	32
Precast Concrete City Inlet Top Slabs . . . . .	33
Precast Inlet Adjustment Risers . . . . .	34
Concrete or Brick Inlets: Highway Grate Inlet; City Inlet . . . . .	35
Inlet Grates . . . . .	36
Inlet Frames . . . . .	37

# CONTENTS

TITLE	PAGE
<b>STANDARD DETAILS FOR SEWERS</b>	
City Inlet Top Slab Clean-Out Cover & Frame .....	38
Inlet Trap .....	39
<b>STANDARD SPECIFICATIONS FOR SEWERS</b>	
D-1 General Description .....	41
D-2 Standard Details .....	41
D-3 Abbreviations and Definitions .....	41
D-4 Requirements, Tests and Inspection .....	42
D-5 Line and Grades .....	42
D-6 Width of Trenches .....	42
D-7 Installation of Pipes .....	42
D-8 Protection of Pipes .....	43
D-9 Length of Pipes .....	43
D-10 Provisions for Lateral Connections .....	43
D-11 Measurement for Payment .....	43
D-12 Filling Abandoned Sewers .....	43
D-13 Filling Abandoned Manholes .....	44
D-14 Filling Abandoned Inlets .....	44
D-15 Vitrified Clay Pipe .....	44
D-16 Reinforced Concrete Pipe .....	45
D-17 Cast-in-Place, Reinforced Concrete Sewers, Stormwater Conduits and Special Sections .....	46
D-18 Precast, Reinforced Concrete Sewers and Stormwater Conduits .....	49
D-19 Ductile Iron Pipe .....	50
D-20 Cast Iron Soil Pipe .....	51
D-21 Manholes .....	51
D-22 Wellholes .....	54
D-23 Inlets .....	55
D-24 Chain Link Fence .....	59

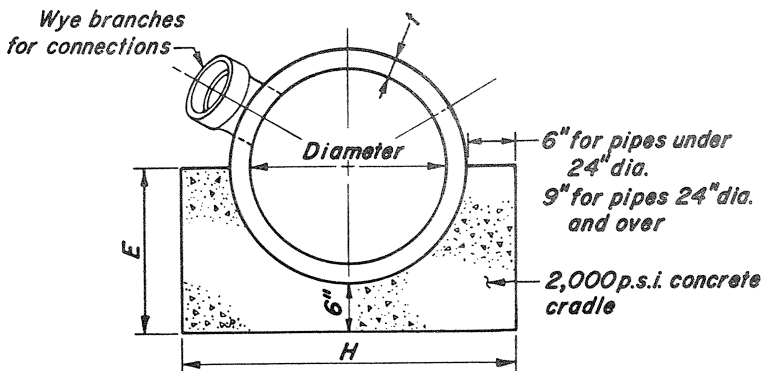

Dia.	t	H	E	CONC. C.Y./L.F.	BELL O.D.±
10"	1"	2'-0"	12"	0.060	16"
12"	1 <sup>3</sup> / <sub>16</sub> "	2'-2 <sup>3</sup> / <sub>8</sub> "	13"	0.067	19"
15"	1 <sup>1</sup> / <sub>2</sub> "	2'-6"	15"	0.083	24"
18"	1 <sup>7</sup> / <sub>8</sub> "	2'-9 <sup>3</sup> / <sub>4</sub> "	17"	0.100	28"
21"	2 <sup>1</sup> / <sub>4</sub> "	3'-1 <sup>1</sup> / <sub>2</sub> "	19"	0.115	33"
24"	2 <sup>1</sup> / <sub>2</sub> "	3'-11"	20 <sup>1</sup> / <sub>2</sub> "	0.174	37"
27"	2 <sup>3</sup> / <sub>4</sub> "	4'-2 <sup>1</sup> / <sub>2</sub> "	22"	0.179	39"
30"	3"	4'-6"	2'-0"	0.202	44"
36"	3 <sup>1</sup> / <sub>2</sub> "	5'-1"	2'-3 <sup>1</sup> / <sub>2</sub> "	0.245	50"
42"	4"	5'-8"	2'-7"	0.255	60"

**NOTE:**

For Vitrified Clay Pipe, "Entirely Encased", extend concrete cradle as shown, to six (6) inches above top of barrel.

**VITRIFIED CLAY PIPE SEWER**

**NOTE:**

For R.C. Pipe, "Entirely Encased", extend concrete cradle as shown, to six (6) inches above top of barrel.

Saddles or Wye branches  
for connections

2,000 p.s.i. concrete  
cradle

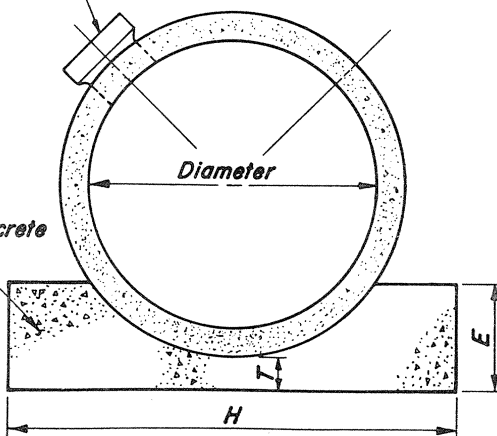

Dia.	T	E	H	CONC. C.Y. / L.F.
15"	4"	9"	2'-7"	0.052
18"	4"	10"	3'-0"	0.070
21"	4"	11"	3'-3"	0.080
24"	4"	11 1/2"	3'-6"	0.089
27"	4"	12 1/2"	3'-9"	0.099
30"	4"	13"	4'-1"	0.112
36"	4"	15"	4'-8"	0.140
42"	4"	17"	5'-4"	0.174
48"	4 1/2"	19"	6'-0"	0.219
54"	5"	21"	6'-8"	0.286
60"	5 1/2"	23 1/2"	7'-2"	0.315
66"	6"	26"	7'-9"	0.371
72"	6 1/2"	28"	8'-4"	0.428
78"	7"	30"	8'-11"	0.489
84"	7 1/2"	32 1/2"	9'-6"	0.558
90"	7 1/2"	34"	9'-10"	0.637
96"	7 1/2"	36"	10'-5"	0.654
102"	7 1/2"	38"	10'-11"	0.696
108"	7 1/2"	39 1/2"	11'-8"	0.776

**R.C. PIPE SEWER  
AND  
STORMWATER CONDUIT**

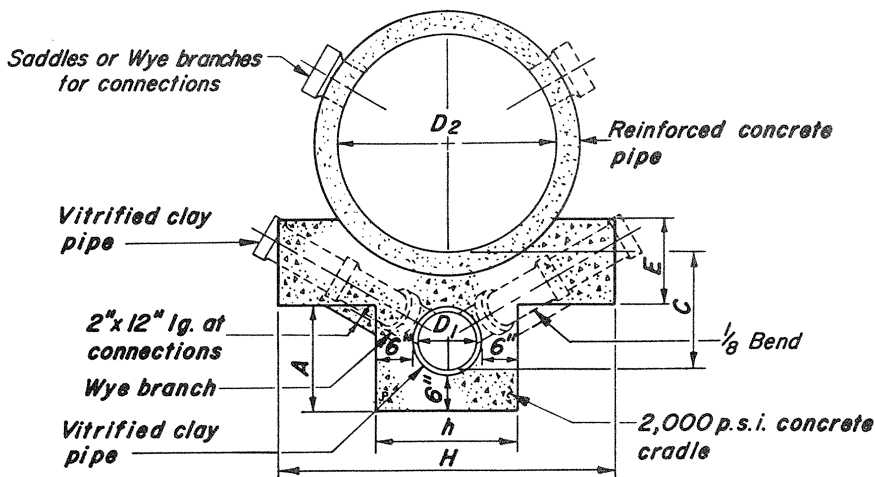

Size		A	h	H	E	C	CONC. C.Y./L.F.
D <sub>1</sub>	D <sub>2</sub>						
10"	15"	1.76'	2'-0"	2'-7"	9"	1.51'	0.157
10"	18"	1.78'		3'-0"	10"	1.53'	0.173
10"	21"	1.80'		3'-3"	11"	1.55'	0.185
10"	24"	1.82'		3'-6"	11½"	1.57'	0.194
10"	27"	1.84'		3'-9"	12½"	1.59'	0.207
10"	30"	1.88'		4'-1"	13"	1.63'	0.222
10"	36"	1.90'		4'-8"	15"	1.65'	0.251
10"	42"	2.29'		5'-4"	17"	2.04'	0.315
10"	48"	2.25'		6'-0"	19"	2.04'	0.356
10"	54"	2.23'		6'-8"	21"	2.06'	0.405
12"	24"	2.01'	2'-2 <sup>3</sup> / <sub>8</sub> "	3'-6"	11½"	1.74'	0.216
12"	27"	2.03'		3'-9"	12½"	1.76'	0.228
12"	30"	2.06'		4'-1"	13"	1.79'	0.243
12"	36"	2.08'		4'-8"	15"	1.81'	0.272
12"	42"	2.48'		5'-4"	17"	2.21'	0.340
12"	48"	2.43'		6'-0"	19"	2.21'	0.381
12"	54"	2.41'		6'-8"	21"	2.23'	0.429
12"	60"	2.37'		7'-2"	23½"	2.23'	0.472
12"	66"	2.33'		7'-9"	26"	2.23'	0.525

**VIT. CLAY PIPE SEWER  
WITH  
R.C. PIPE SW. CONDUIT**

Slants for connections

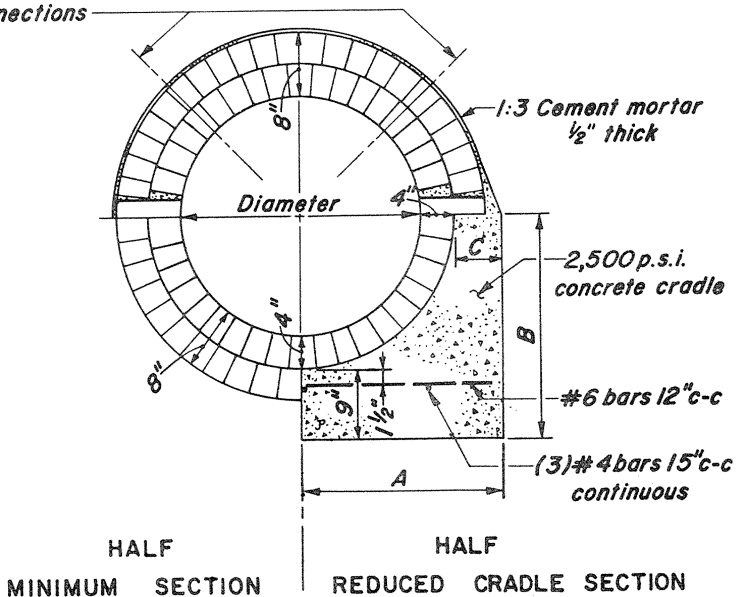

REDUCED CRADLE

Dia.	A	B	C
2'-0"	22"	2'-1"	6"
2'-6"	2'-1"	2'-4"	6"
3'-0"	2'-8"	2'-7"	10"
3'-6"	2'-11"	2'-10"	10"
4'-0"	3'-2"	3'-1"	10"
4'-6"	3'-5"	3'-4"	10"

## CIRCULAR BRICK SEWER

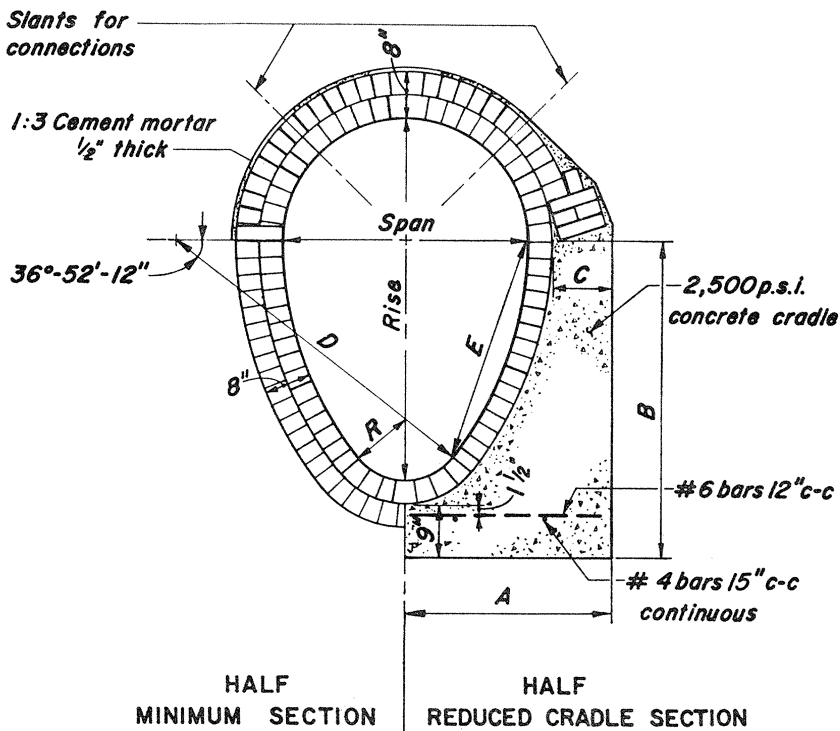

Rise x Span	A	B	C	D	E	R	VOIDS C.X./L.F.
2'-3" x 1'-6"	19"	2'-7"	6"	2'-3"	17 1/8"	4 1/2"	0.096
2'-6" x 1'-8"	20"	2'-9"	6"	2'-6"	19"	5"	0.118
3'-0" x 2'-0"	22"	3'-1"	6"	3'-0"	22 3/4"	6"	0.170
3'-6" x 2'-4"	2'-0"	3'-5"	6"	3'-6"	2'-2 5/8"	7"	0.232
4'-0" x 2'-8"	2'-2"	3'-9"	6"	4'-0"	2'-6 3/8"	8"	0.303
4'-6" x 3'-0"	2'-8"	4'-1"	10"	4'-6"	2'-10 1/8"	9"	0.383
5'-0" x 3'-4"	2'-10"	4'-5"	10"	5'-0"	3'-2"	10"	0.473

## EGG - SHAPED BRICK SEWER



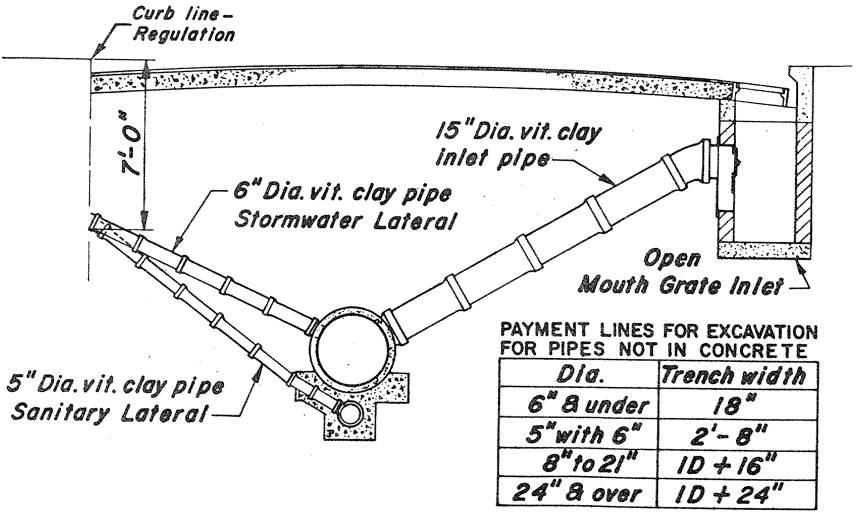

**TYPICAL STREET SECTION**

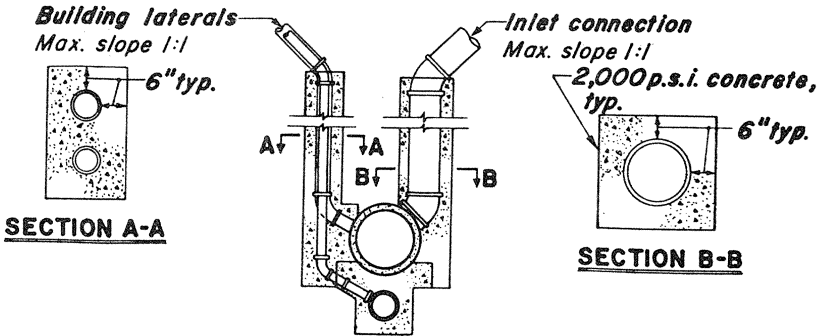

**TYPICAL LATERAL RISERS**

**LATERALS  
SEPARATE SYSTEM**

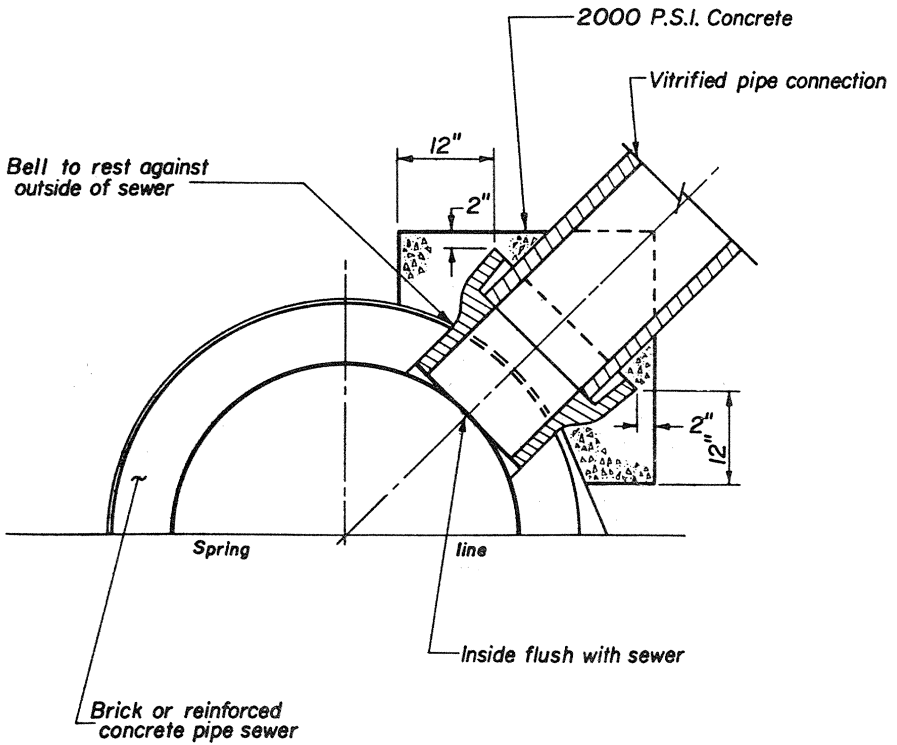

**SADDLE CONNECTION TO  
 BRICK OR R.C. PIPE SEWERS**

**NOTE:**

Sanitary sewer to be entirely encased in concrete through turnout.

4' Pipe lengths, maximum deflection of opening  $\frac{3}{4}$ " - each joint

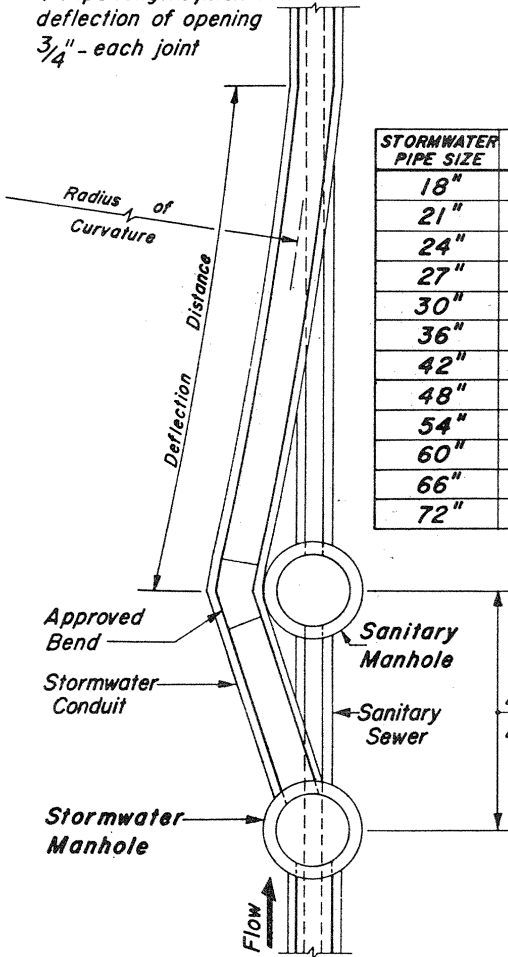

STORMWATER PIPE SIZE	NO. PIPE LENGTHS	DEFLECTION DISTANCE	RADIUS OF CURVATURE*
18"	9	38'	123'
21"	9	38'	141'
24"	10	42'	160'
27"	11	46'	179'
30"	11	46'	197'
36"	12	50'	235'
42"	14	58'	272'
48"	15	62'	309'
54"	17	70'	347'
60"	18	80'	384'
66"	18	80'	421'
72"	19	88'	459'

\* Minimum

20'-For 18" to 36" dia. SW. pipe  
25'-For 42" to 72" dia. SW. pipe

**STORMWATER TURNOUT  
FOR  
SEPARATE SYSTEM**

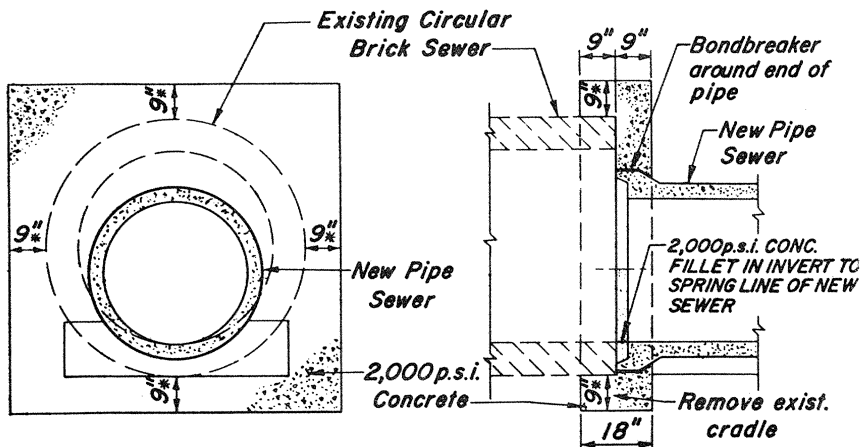

### PIPE AND CIRCULAR BRICK SEWERS

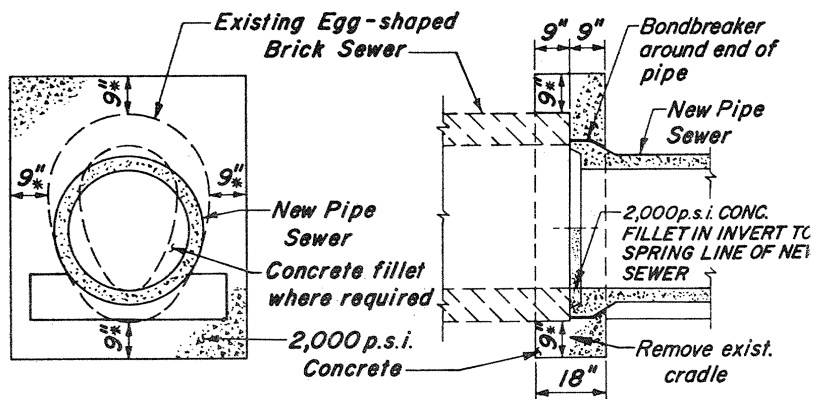

### PIPE AND EGG-SHAPED BRICK SEWERS

\* Where outside surface of new sewer extends beyond existing sewer, the 9" dimension shall be from the new sewer.

## CONCRETE COLLARS AT CONNECTIONS

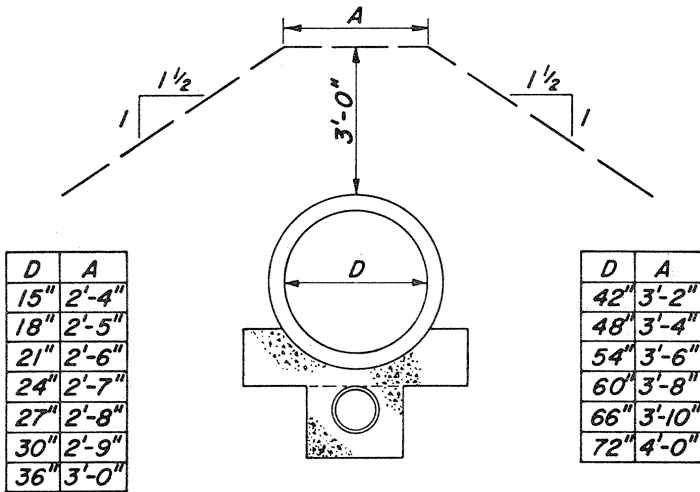

**R.C. PIPE - SEPARATE OR COMBINED SYSTEM**

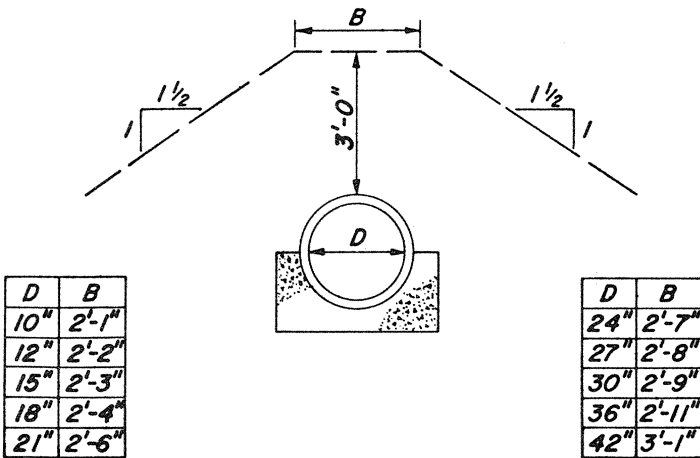

**VIT. CLAY PIPE SEWER**

**EMBANKMENT OVER PIPES**

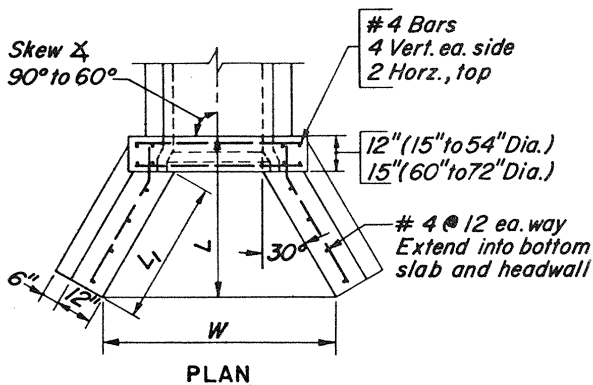

① Installation of standard chain link fence on headwall to be determined by the Chief of Design.

② Length of paved outlet to be checked or determined by velocity of flow.

Concrete - 3,500 p.s.i Air-Entrained

Reinforcing bars shall conform to ASTM A615 Grade 40

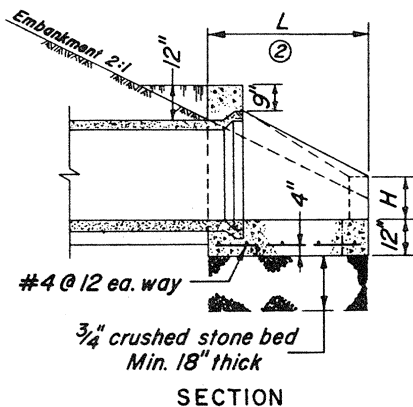
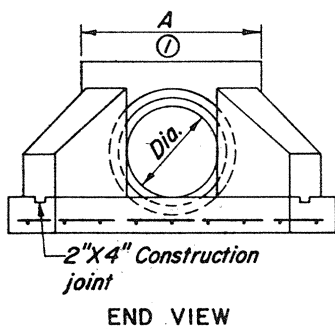

Dia.	A	L	L <sub>1</sub>	W	H
15"	3'-9"	3'-0"	2'-4"	3'-7"	12"
18"	4'-0"	3'-6"	2'-10"	4'-5"	12"
21"	4'-3"	4'-0"	3'-6"	5'-3"	12"
24"	4'-6"	4'-6"	4'-0"	6'-0"	12"
27"	4'-9"	4'-6"	4'-0"	6'-3"	14"
30"	5'-0"	4'-6"	4'-0"	6'-6"	15"
36"	5'-10"	4'-8"	4'-3"	7'-3"	18"
42"	6'-4"	5'-9"	5'-6"	9'-0"	21"
48"	6'-11"	6'-10"	6'-9"	10'-9"	2'-0"
54"	7'-6"	7'-11"	8'-0"	12'-6"	2'-3"
60"	8'-1"	9'-0"	8'-11"	14'-0"	2'-6"
72"	9'-3"	11'-2"	11'-5"	17'-5"	3'-0"

## PIPE ENDWALL

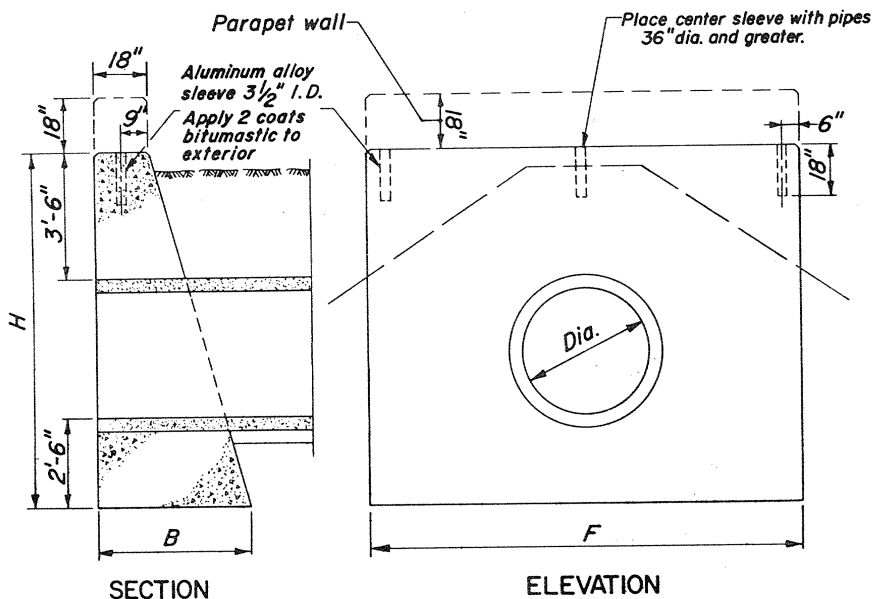

**NOTE:**

Walls to be 3500 P.S.I., air-entrained concrete or rubble masonry pointed.

All exposed concrete edges to be chamfered one inch.

Parapet wall to be used only where required and ordered.

Headwall Dimensions				
Dia.	H	B	F	C.Y.
15"	7'-5 $\frac{1}{4}$ "	3'-2"	7'-0"	4.31
18"	7'-8 $\frac{1}{2}$ "	3'-3"	8'-0"	5.23
21"	7'-11 $\frac{3}{4}$ "	3'-4"	8'-6"	5.71
24"	8'-3"	3'-5"	9'-0"	6.29
27"	8'-6 $\frac{1}{4}$ "	3'-8"	9'-6"	7.12
30"	8'-9 $\frac{1}{2}$ "	3'-9"	10'-0"	7.78
36"	9'-4"	4'-0"	11'-0"	9.31
42"	9'-10 $\frac{1}{2}$ "	4'-3"	12'-0"	11.37
48"	10'-5"	4'-5"	13'-0"	12.69
54"	10'-11 $\frac{1}{2}$ "	4'-9"	14'-0"	14.91
60"	11'-6"	5'-0"	15'-0"	16.13
66"	12'-0 $\frac{1}{2}$ "	5'-3"	16'-0"	19.53
72"	12'-7"	5'-6"	17'-0"	22.12

**PIPE  
HEADWALL**

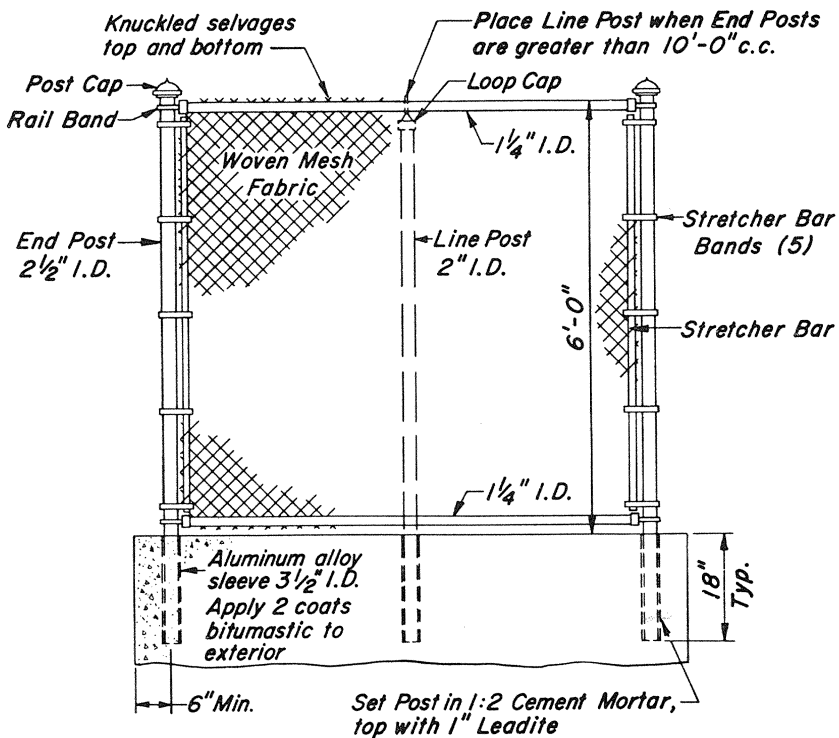

PIPE ENDWALL OR HEADWALL

CHAIN LINK FENCE



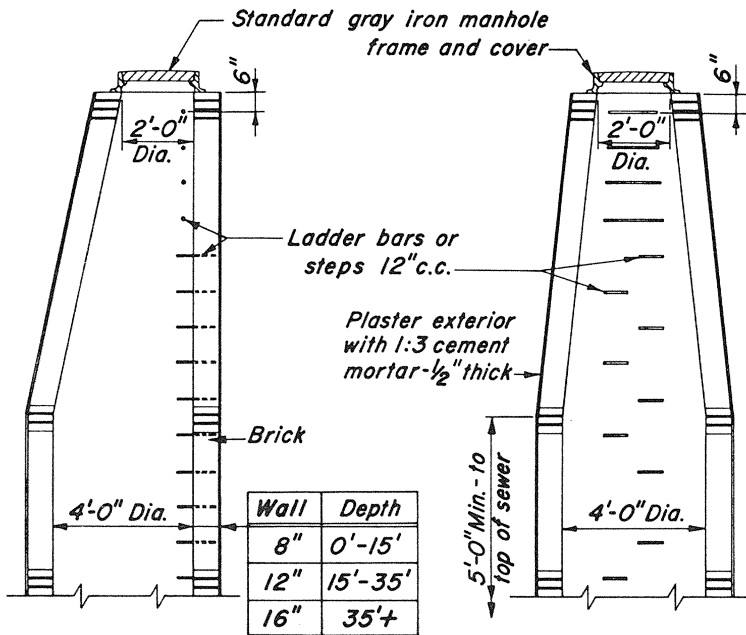

RISER AND CONE

**BRICK MANHOLE**

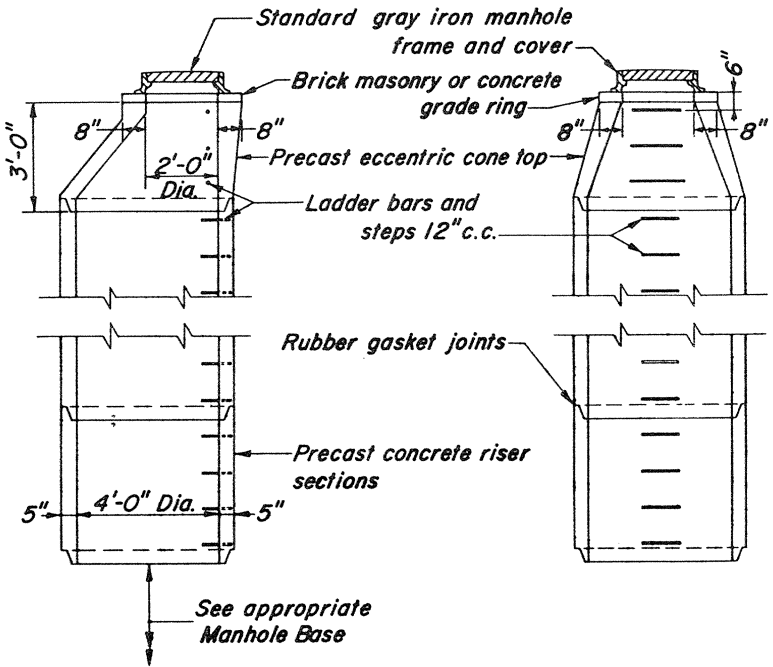

RISER AND CONE

PRECAST CONCRETE MANHOLE

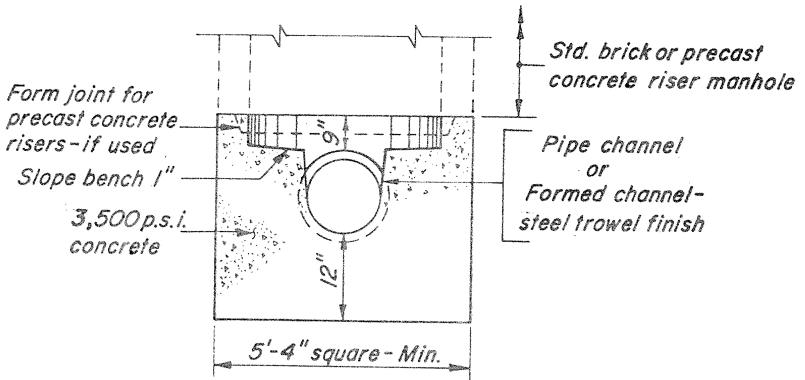
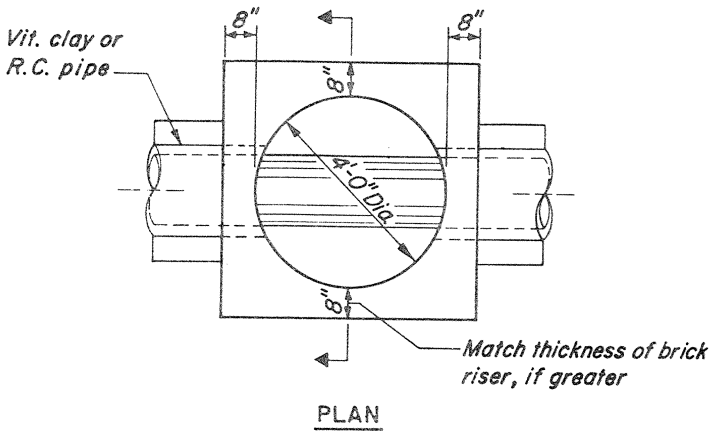

30" DIA. AND UNDER

## CONCRETE MANHOLE BASE

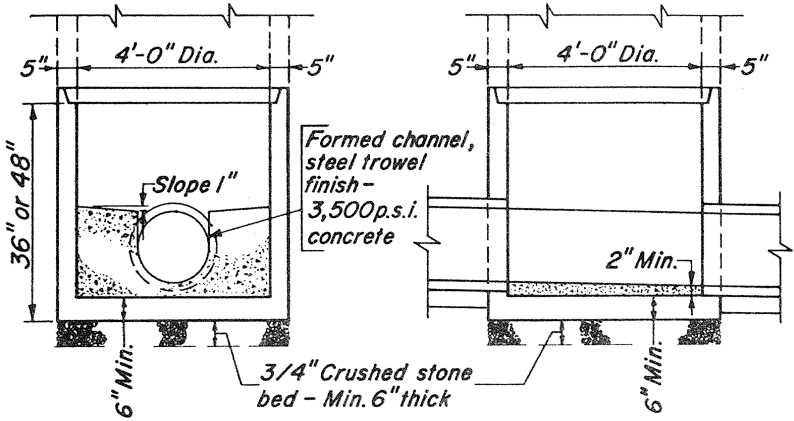

PIPE - 30" DIA. AND UNDER

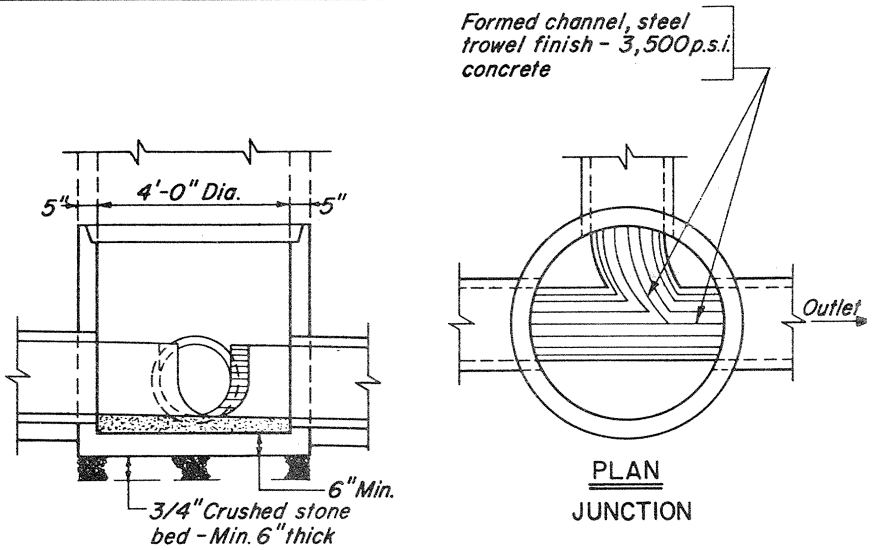

PLAN  
JUNCTION

JUNCTION MANHOLE  
PIPE - 30" DIA. AND UNDER

**PRECAST CONCRETE MANHOLE BASES**

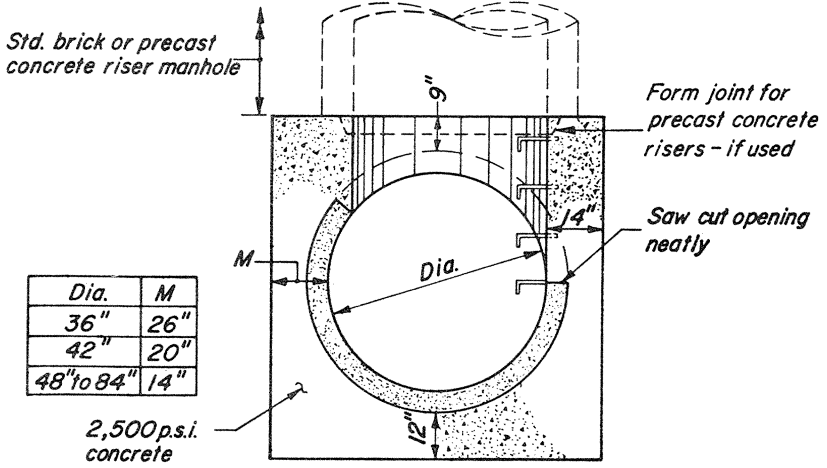
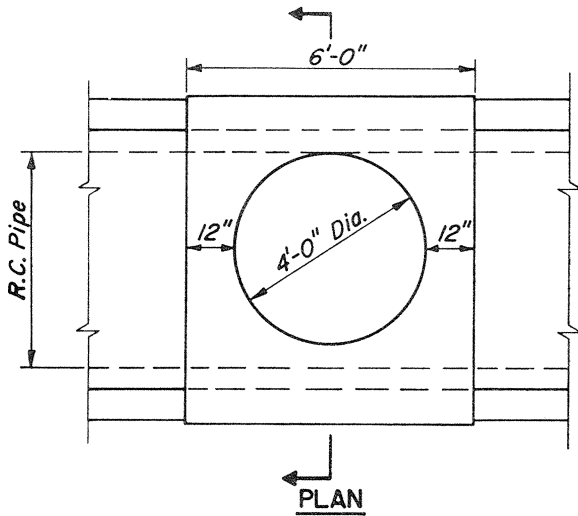

Dia.	M
36"	26"
42"	20"
48" to 84"	14"

36" DIA. AND OVER

## CONCRETE MANHOLE BASE

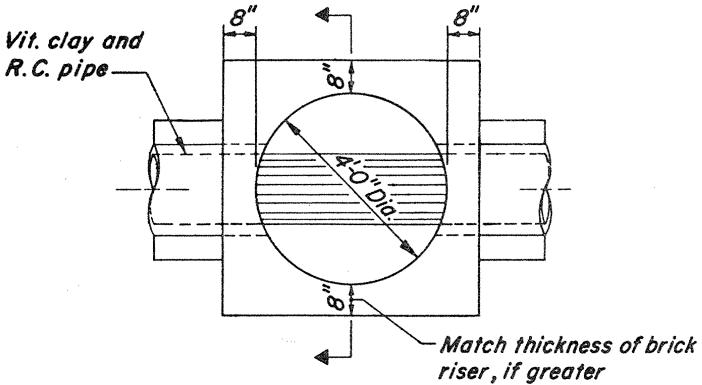

PLAN

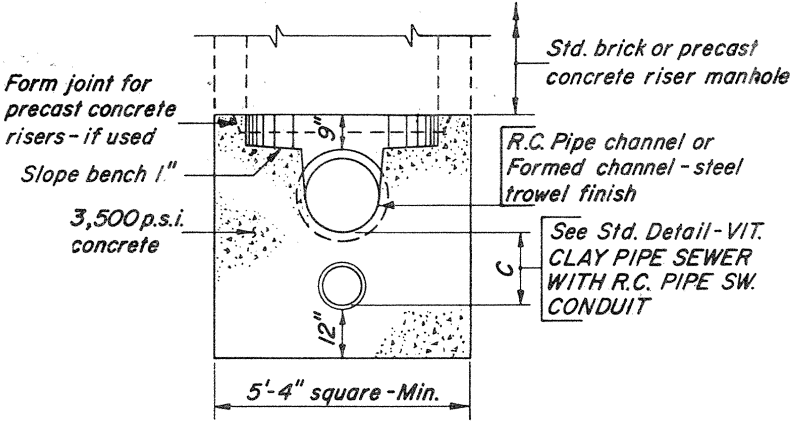

SECTION

STORMWATER MANHOLE - SEPARATE SYSTEM  
STORMWATER PIPE - 30" DIA. AND UNDER

**CONCRETE MANHOLE BASE**

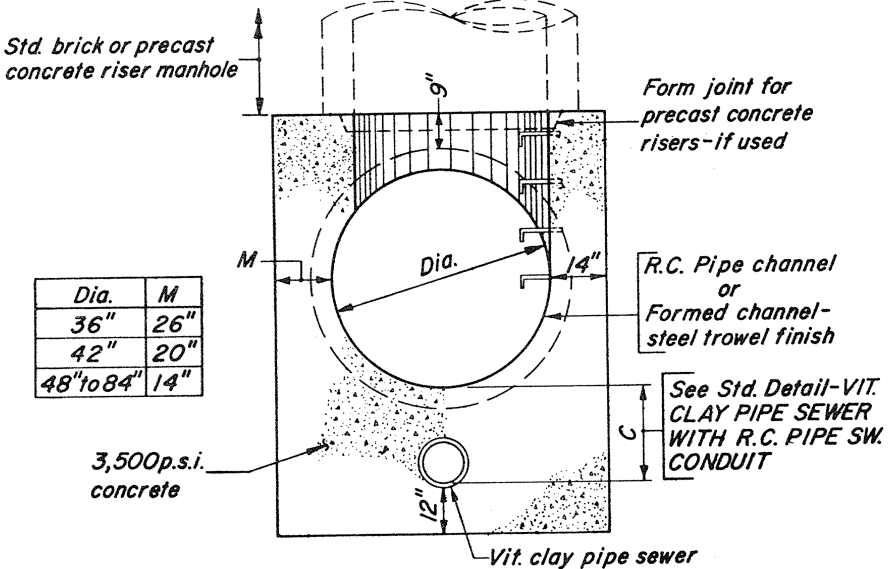
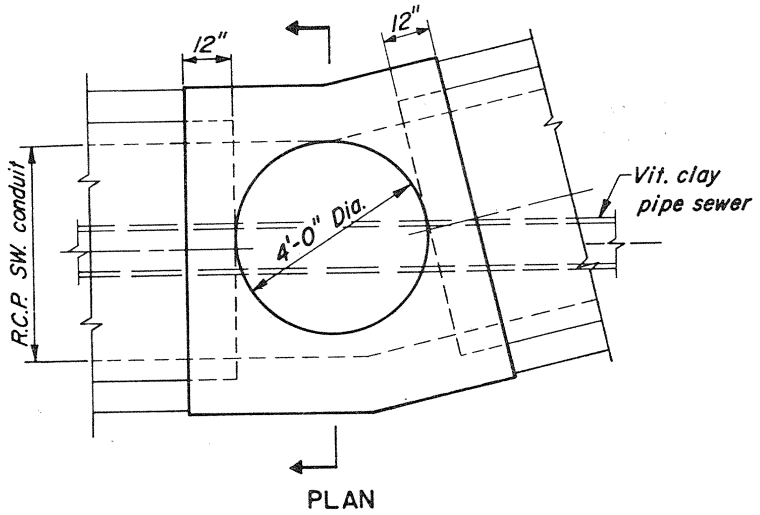

**STORMWATER MANHOLE - SEPARATE SYSTEM**  
**STORMWATER PIPE - 36" DIA. AND OVER**

**CONCRETE MANHOLE BASE**

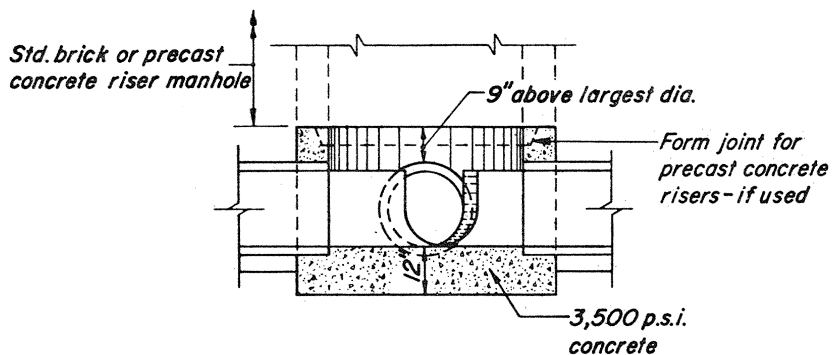
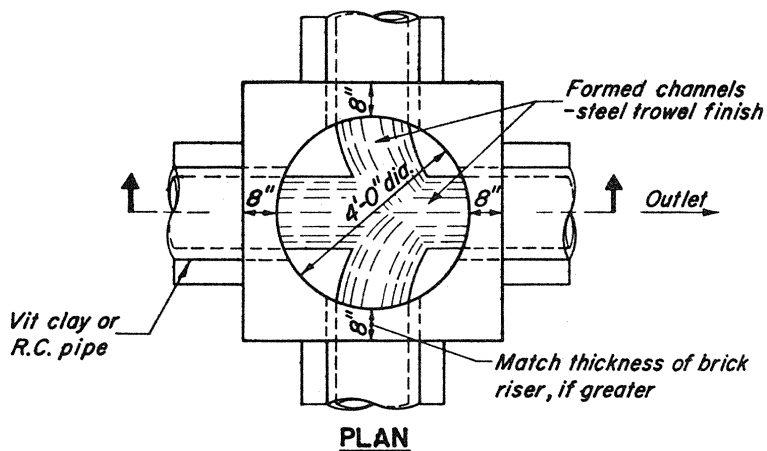

**JUNCTION MANHOLE**

**CONCRETE MANHOLE BASE**



8" dia. vit. clay pipe vent.  
Vent to opposite side of  
manhole or to other sewer  
system. Place horizontal  
vent pipe 6' below grade.

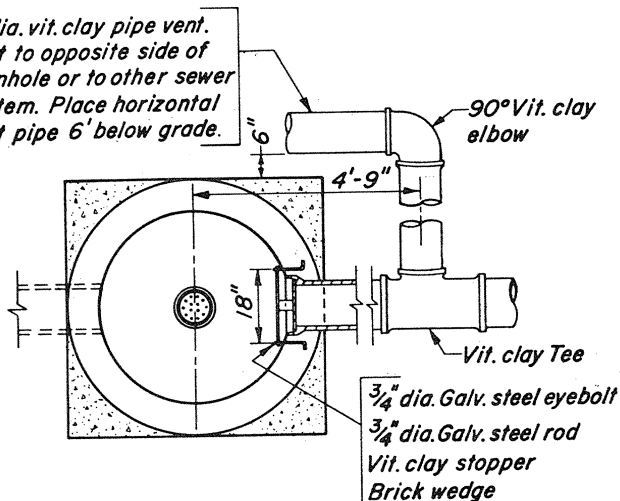

**PLAN - AT BOTTOM**

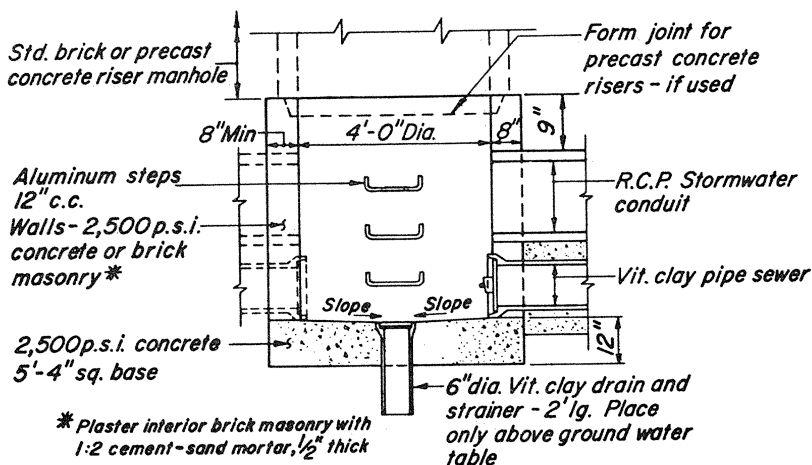

**SUMMIT MANHOLE**

**BRICK OR CONCRETE MANHOLE BASE**

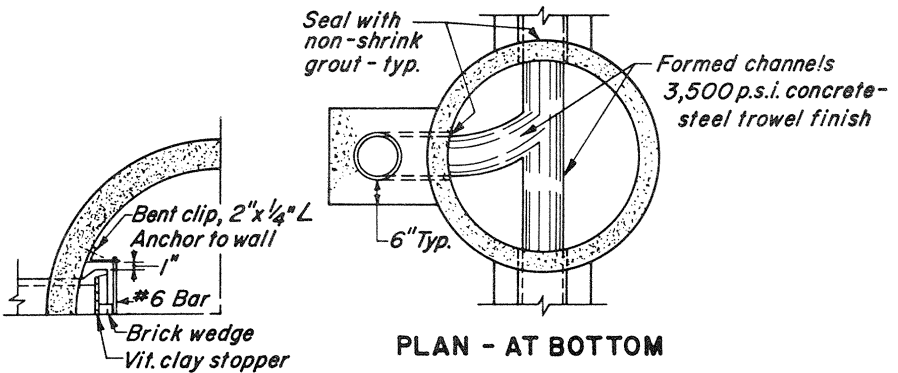
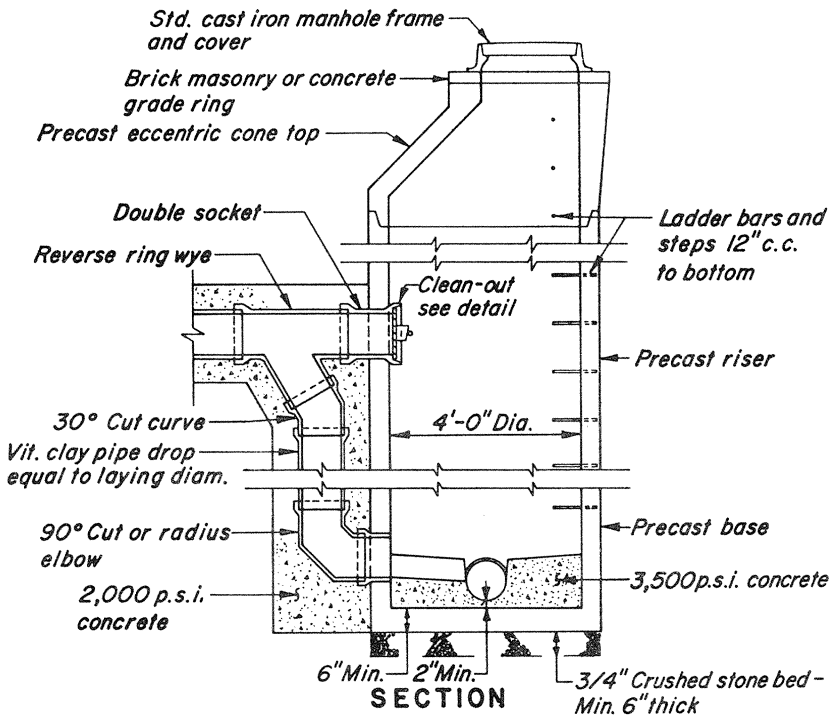

**DETAIL OF CLEAN OUT**

## PRECAST CONCRETE DROP MANHOLE

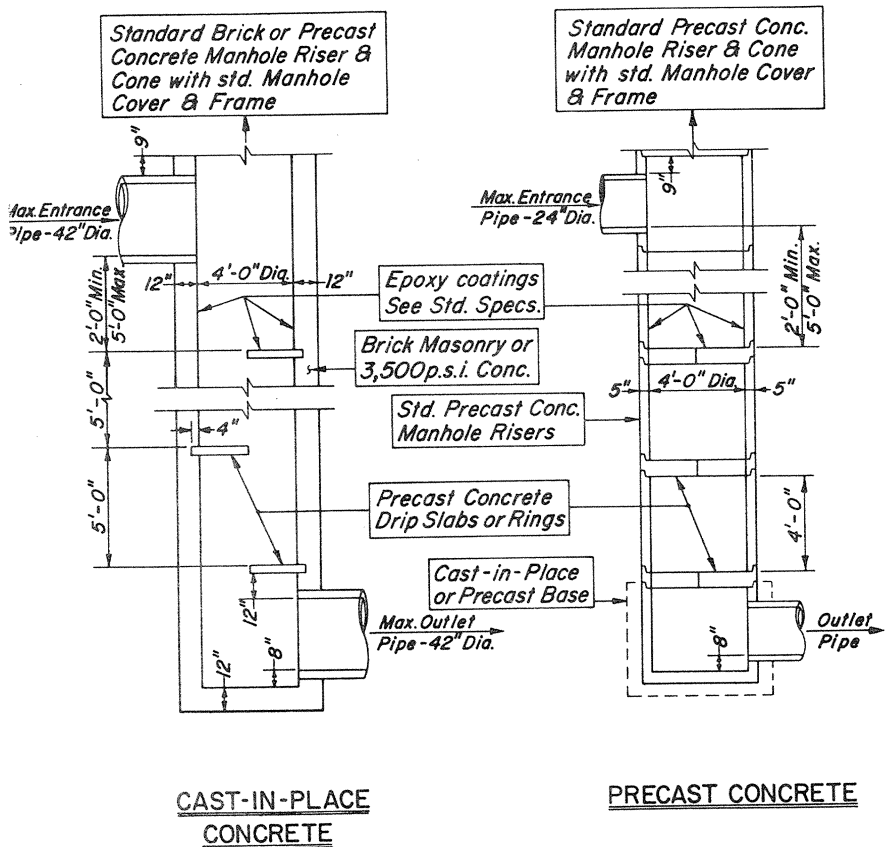

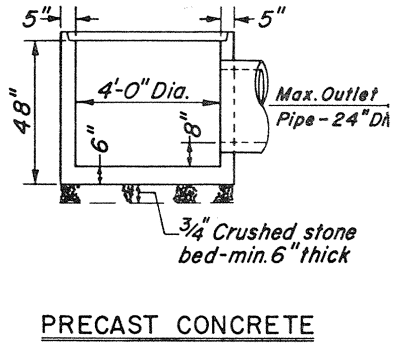
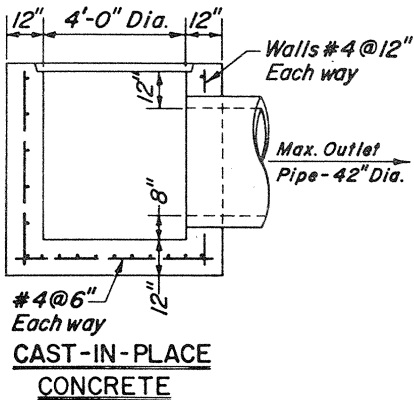
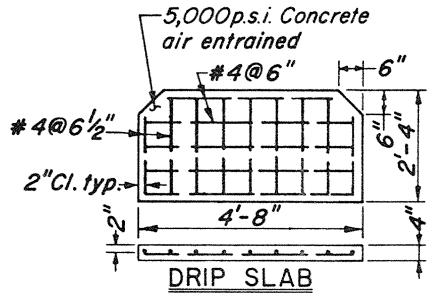
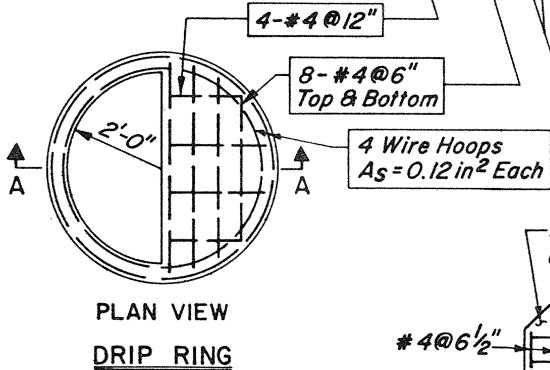
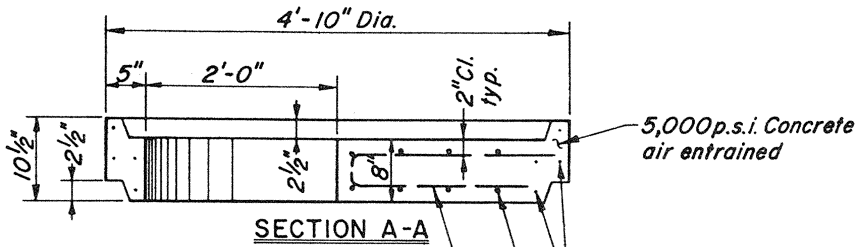

BASE SECTIONS FOR PRECAST WELLHOLE

**WELLHOLE**

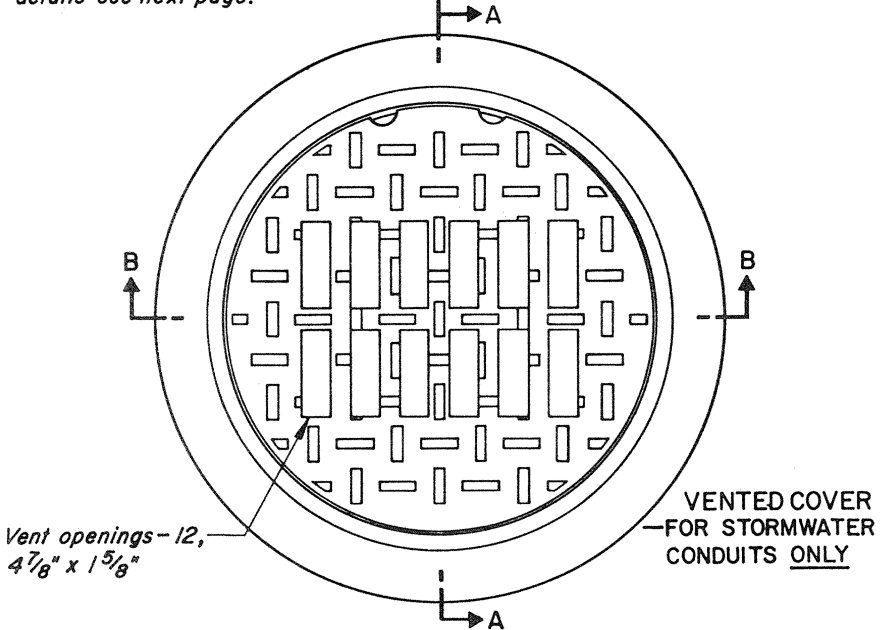
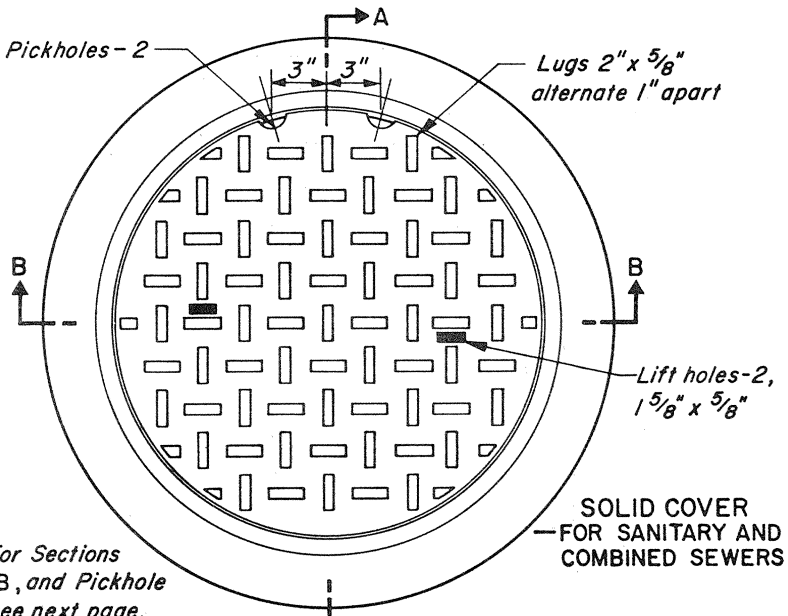

**GRAY IRON MANHOLE  
FRAME & COVERS**

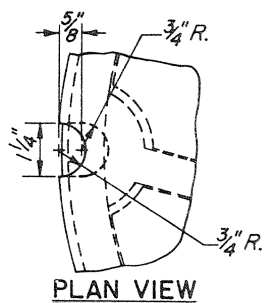
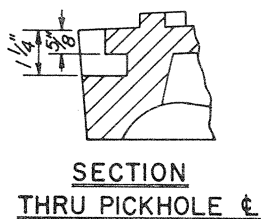
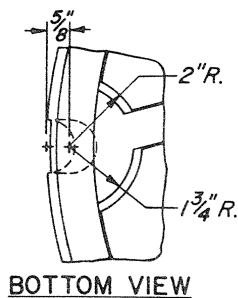
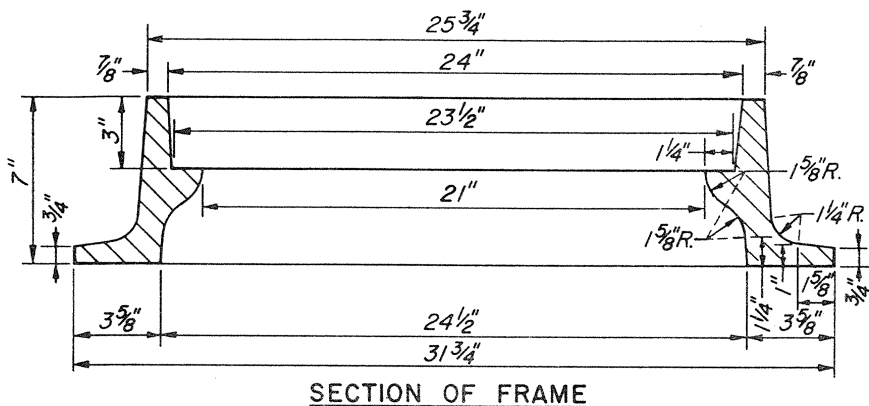
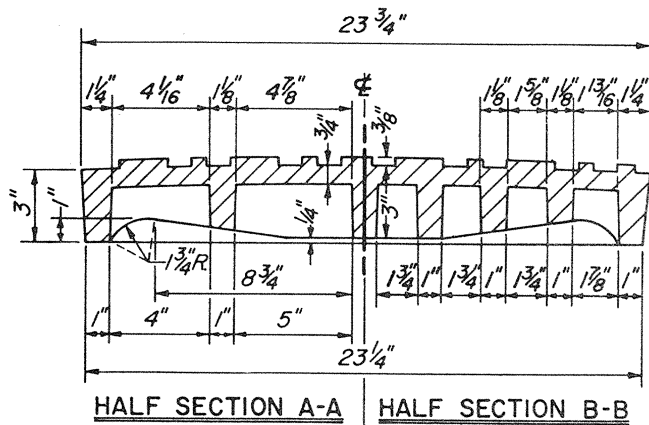

DETAILS OF PICKHOLE

**GRAY IRON MANHOLE  
FRAME & COVERS**

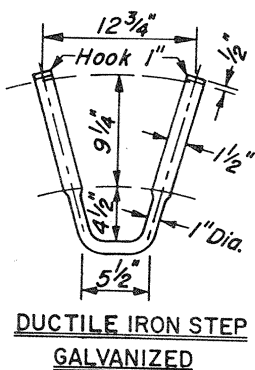
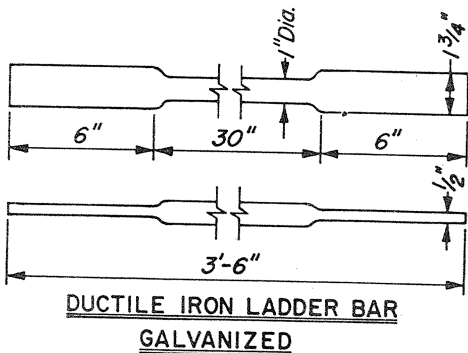

*Embedded ends shall have two coats of bitumastic*

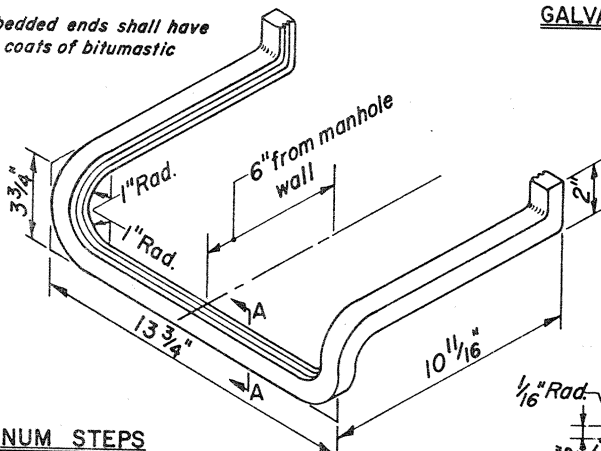

*Embedded ends shall have two coats of bitumastic*

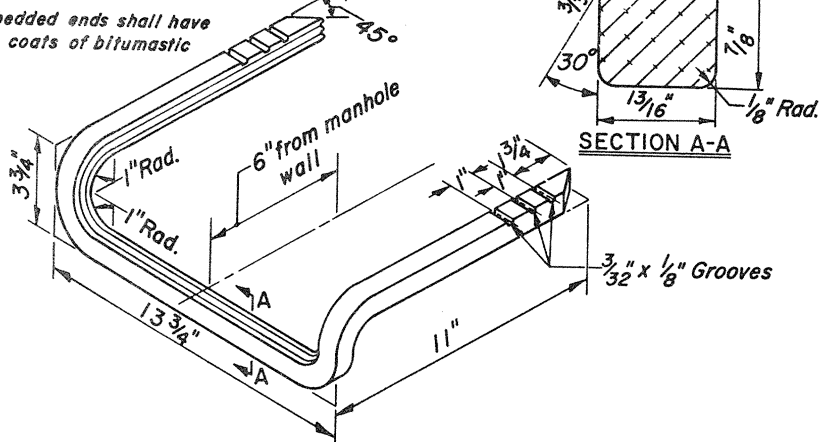

## MANHOLE STEPS AND LADDER BAR

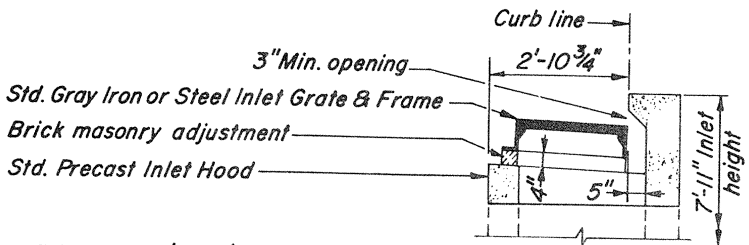

TOP FOR 4' & 6' OPEN MOUTH GRATE INLETS

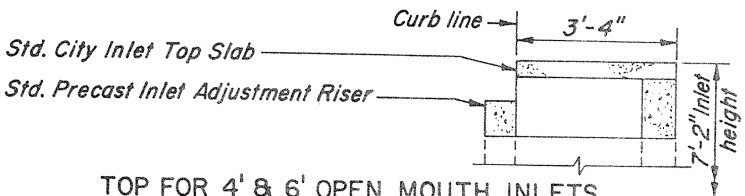

TOP FOR 4' & 6' OPEN MOUTH INLETS

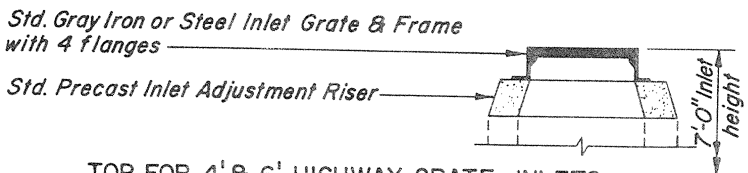

TOP FOR 4' & 6' HIGHWAY GRATE INLETS

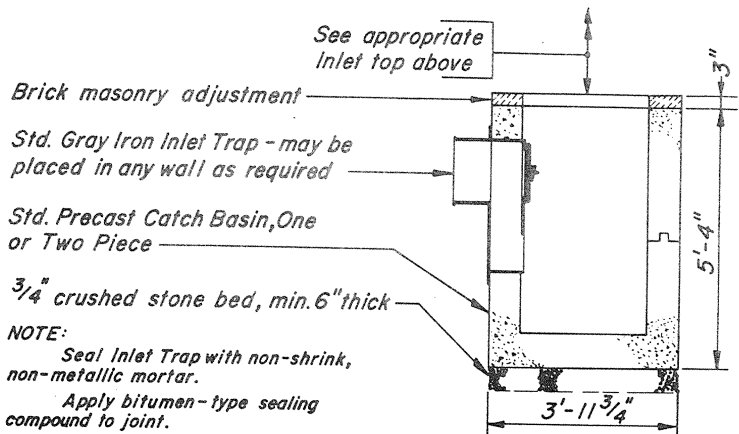

CATCH BASIN

## ASSEMBLY OF PRECAST INLETS



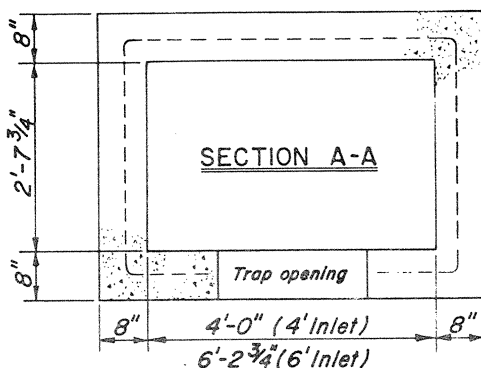

**NOTE:**  
 Concrete to be 4,000 p.s.i.  
 Air-Entrained.  
 Trap opening dimensions are  
 1 inch larger than actual trap  
 dimensions.  
 Trap may be placed in any  
 wall as required.

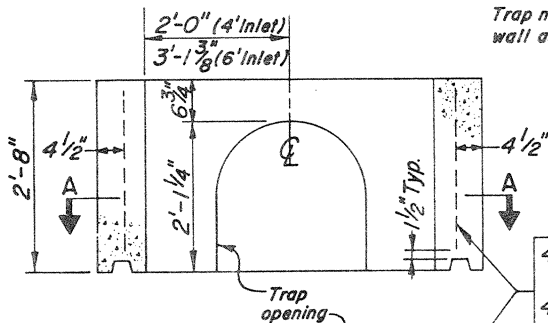

4X4-D4XD4  
 (4' Inlet)  
 4X4-D5XD5  
 (6' Inlet)

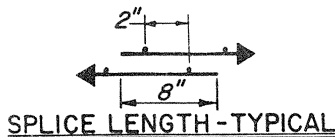
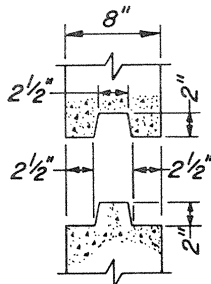
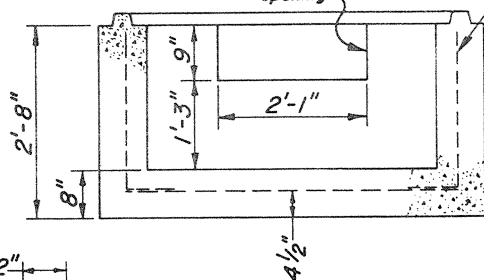

WITH WELDED WIRE FABRIC

**PRECAST CATCH BASIN**

**NOTE:**

All bars # 4, Grade 60.  
 Min. bend dia., 3 inches.  
 Concrete to be 4,000 p.s.i.  
 Air-Entrained.

Trap opening dimensions are 1 inch larger than actual trap dimensions.

Trap may be placed in any wall as required.

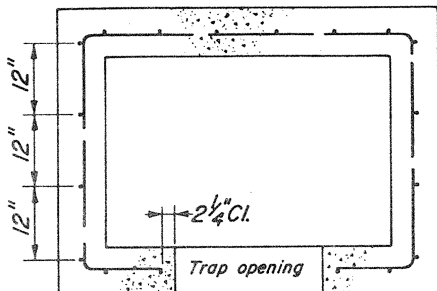

**SECTION B-B**

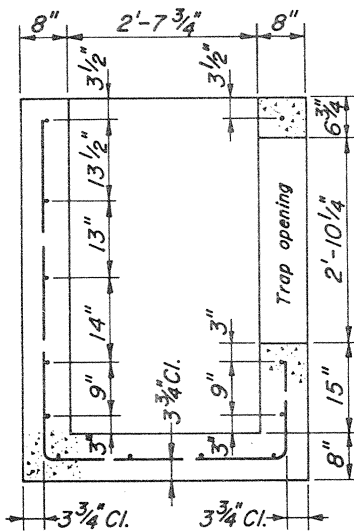

**SECTION A-A**

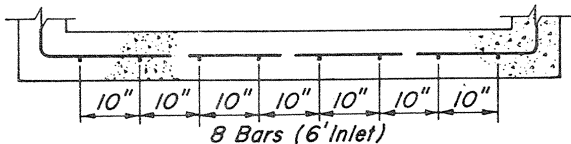
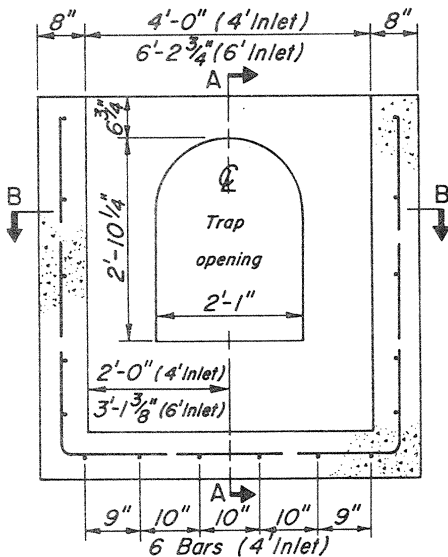

**WITH REINFORCING BARS**

**PRECAST CATCH BASIN**

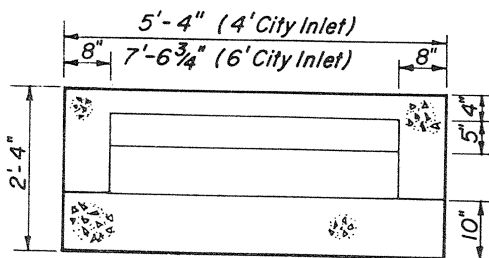

**FRONT**

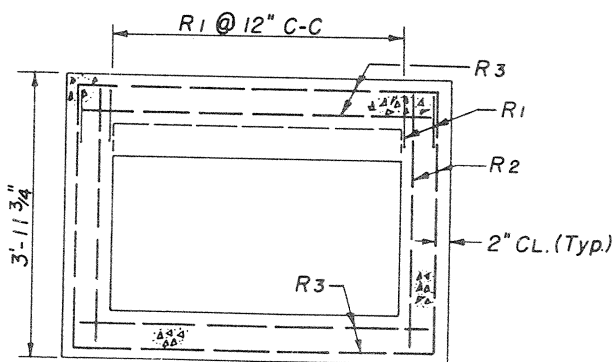

**TOP VIEW**

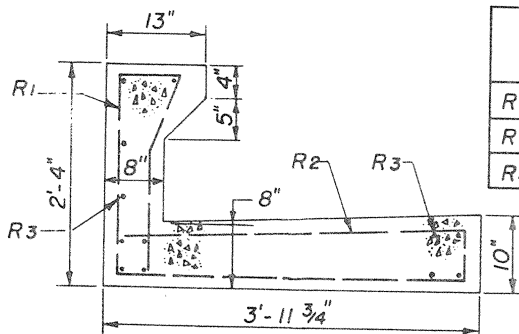

**SECTION**

**BAR SCHEDULE**

	4' INLET		6' INLET	
	Qty.	Length	Qty.	Length
R1	7	4'-8"	9	4'-8"
R2	4	7'-9 1/2"	4	7'-9 1/2"
R3	12	5'-0"	12	7'-2 3/4"

**NOTE:**

Bend  $R_1$  &  $R_2$  as shown.  
 All bars No. 4, Grade 40.  
 Concrete: 4,000 p.s.i. Air-Entrained.

**PRECAST REINFORCED CONCRETE  
 INLET HOOD**

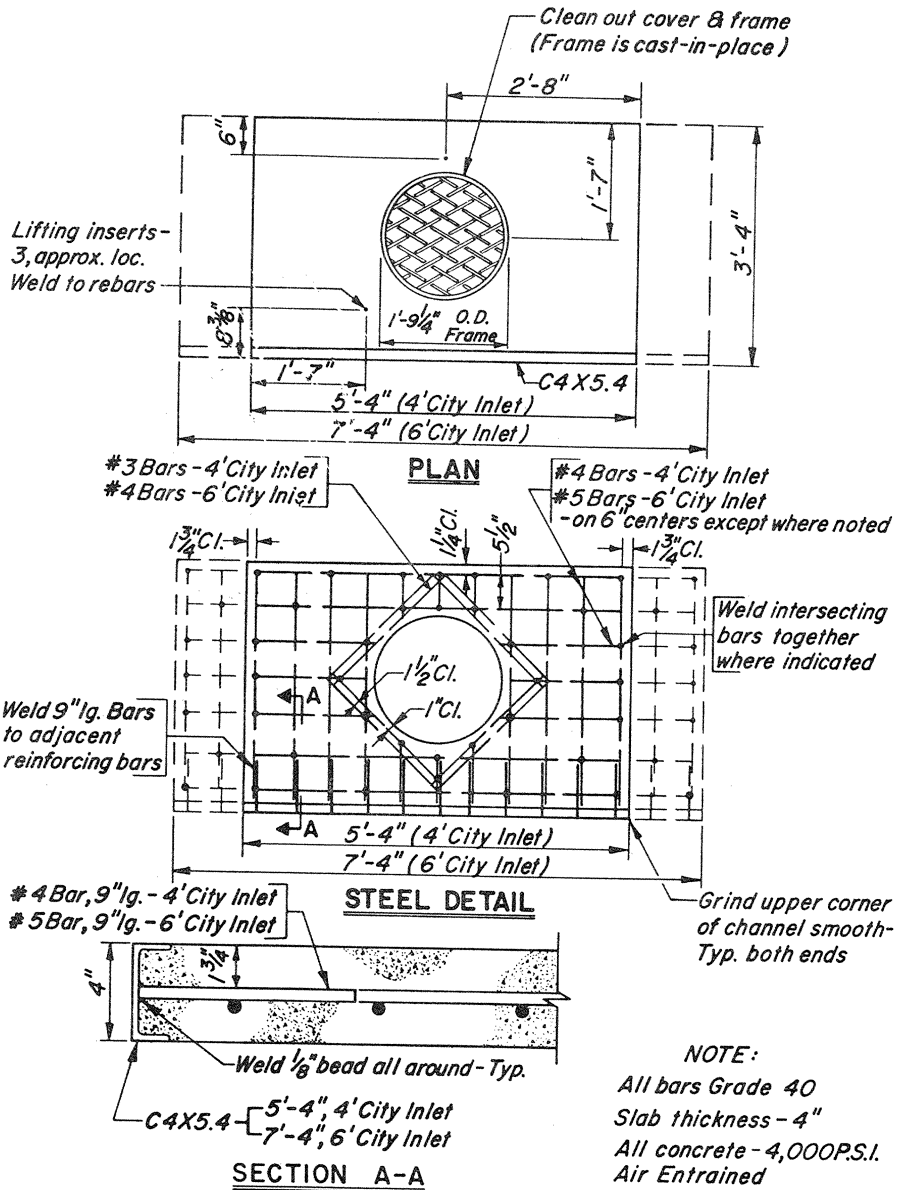

**PRECAST CONCRETE CITY INLET  
TOP SLABS**

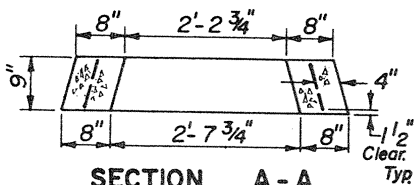

**SECTION A-A**  
**FOR 4' & 6'**  
**HIGHWAY GRATE INLETS**

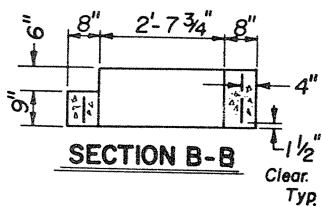
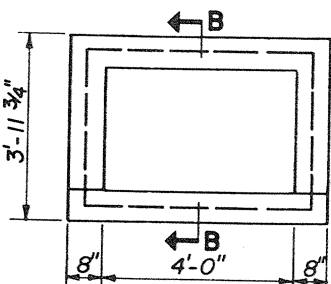
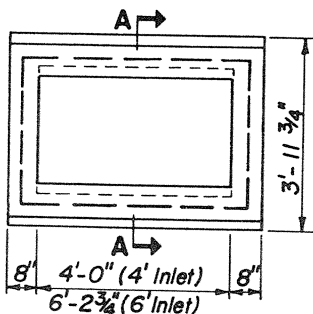

**SECTION B-B**  
**FOR 4' OPEN**  
**MOUTH INLETS**

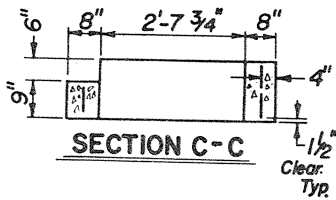

**SECTION C-C**  
**FOR 6' OPEN**  
**MOUTH INLETS**

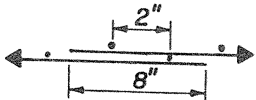
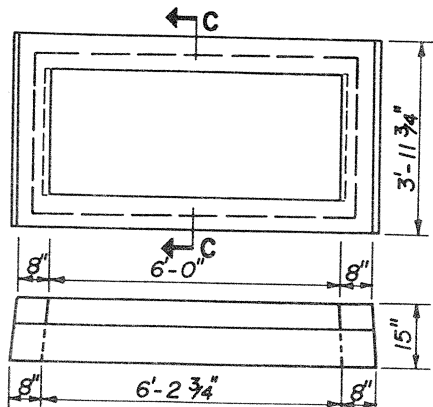

**SPlice LENGTH TYPICAL**

**NOTE:**  
 Concrete to be 4,000 P.S.I., Air-Entrained.  
 Steel reinforcing to be 4 X 4-D4 X D4.

**PRECAST INLET ADJUSTMENT RISERS**

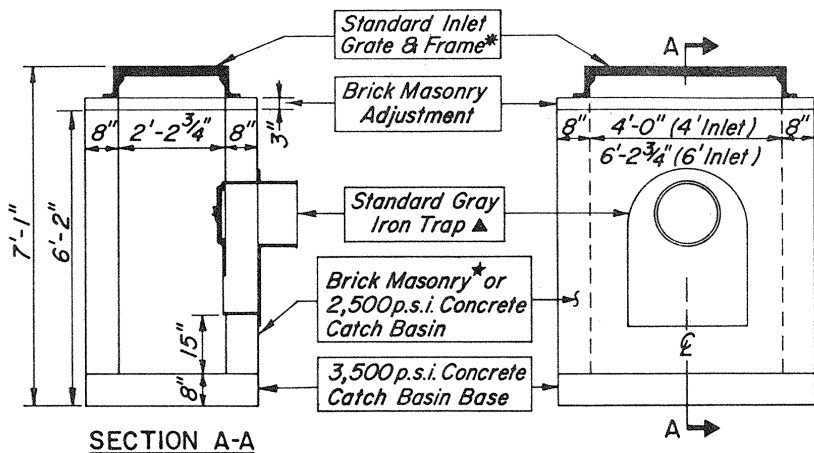

- \* Frame shall have flanges on all four sides.  
 ★ Plaster interior brick masonry with 1:2 cement-sand mortar,  $\frac{1}{2}$ " thick.  
 ▲ Trap may be placed in any wall as required.

**HIGHWAY GRATE INLET**

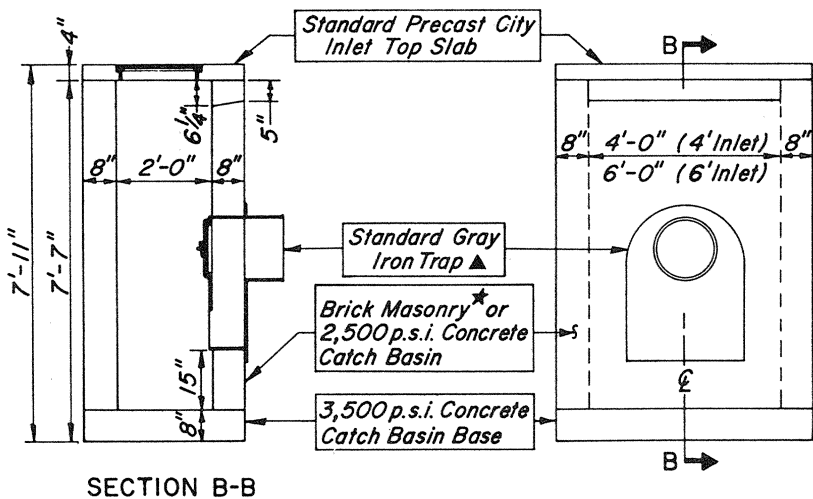

- ★ Plaster interior brick masonry with 1:2 cement-sand mortar,  $\frac{1}{2}$ " thick.  
 ▲ Trap may be placed in any wall as required.

**CITY INLET**

**CONCRETE OR BRICK INLETS**

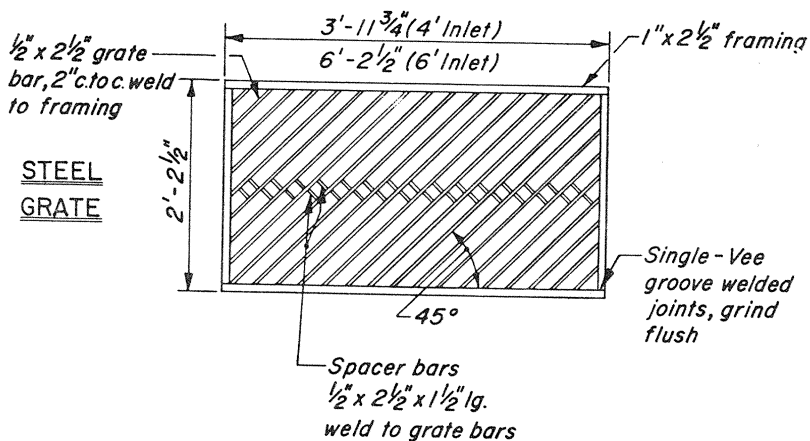
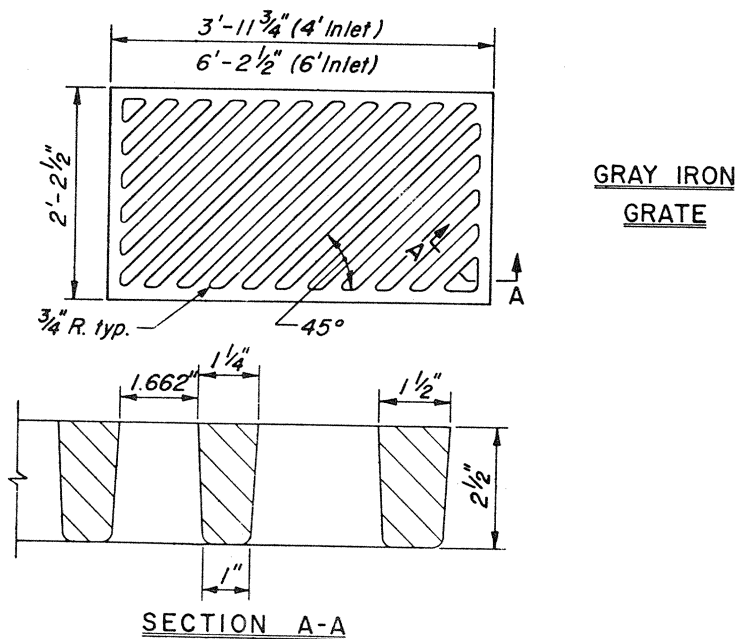

## INLET GRATES

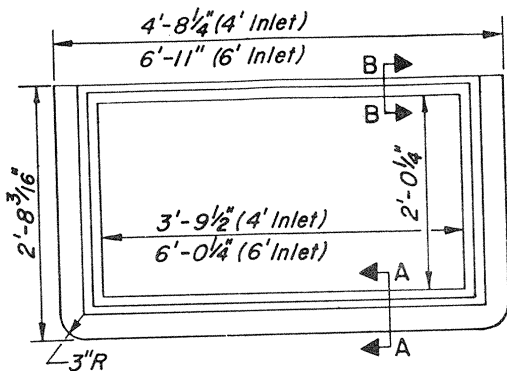

GRAY IRON FRAME

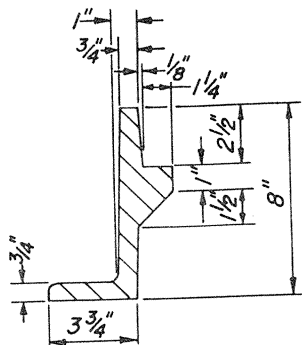

SECTION A-A

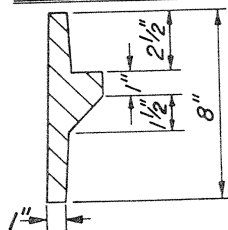

SECTION B-B

NOTE: FOR HIGHWAY GRATE  
INLETS FLANGE ON ALL FOUR  
SIDES

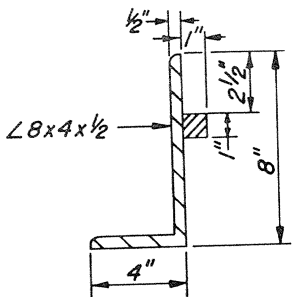

SECTION C-C

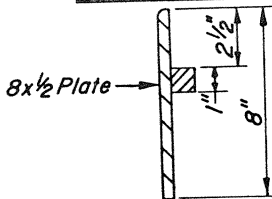

SECTION D-D

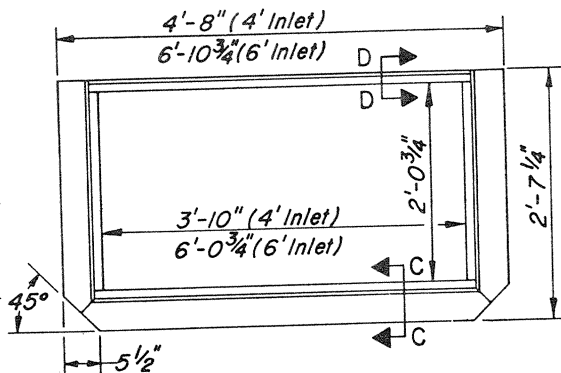

STEEL FRAME

**INLET FRAMES**



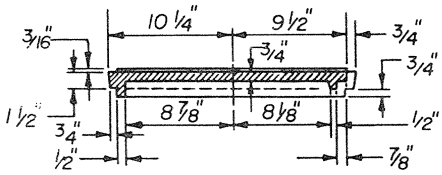
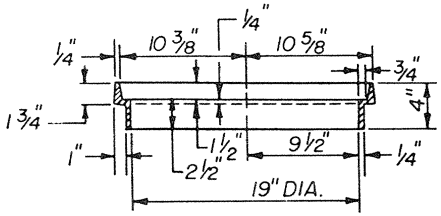

SECTION B - B

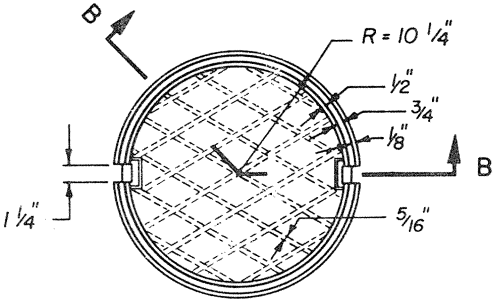

BOTTOM VIEW

CITY INLET  
CLEAN-OUT COVER & FRAME

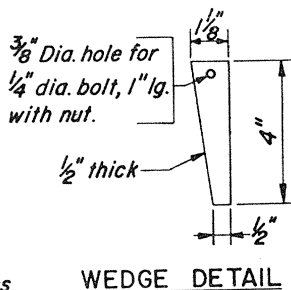
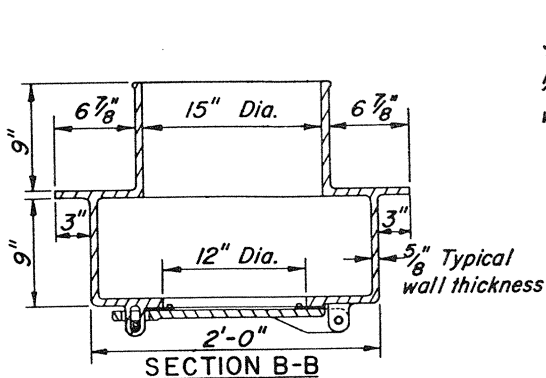

NOTE: TRAP AND DOOR ARE GRAY IRON. APPURTENANT MATERIALS ARE EITHER BRASS OR STAINLESS STEEL TYPE 304.

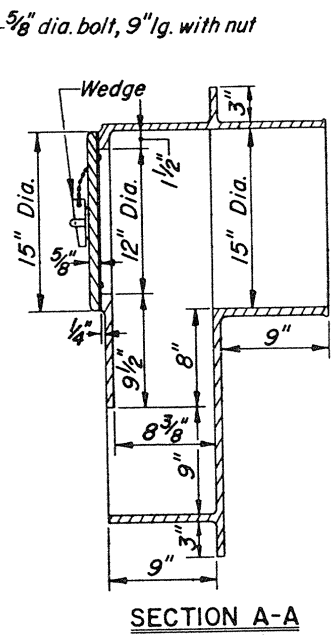
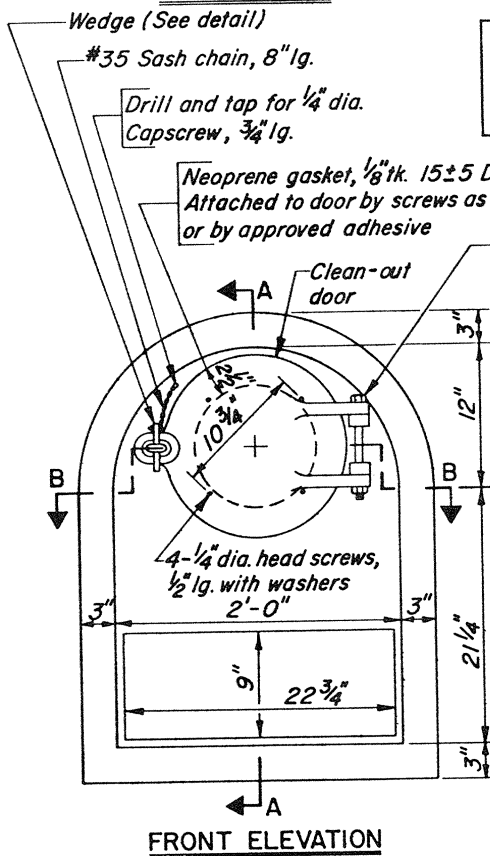

Wedge (See detail)

#35 Sash chain, 8" lg.

Drill and tap for 1/4" dia. Capscrew, 3/4" lg.

Neoprene gasket, 1/8" tk. 15 ± 5 Durometer. Attached to door by screws as shown or by approved adhesive

Clean-out door

5/8" dia. bolt, 9" lg. with nut

4 - 1/4" dia. head screws, 1/2" lg. with washers

# INLET TRAP

# STANDARD SPECIFICATIONS FOR SEWERS AND STORMWATER CONDUITS

## D-1 GENERAL DESCRIPTION

These Specifications shall apply to all sewers and/or stormwater conduits that are constructed for the City of Philadelphia or that are paid for by private cost and inspected by the Water Department. All sewers and/or stormwater conduits that will or that may eventually be maintained by the City must be inspected by the Water Department.

## D-2 STANDARD DETAILS

The Philadelphia Water Department's Standard Details for Sewers, included in this publication, shall apply to sewers and/or stormwater conduits constructed under these specifications, except where the Standard Details are modified by the Plans or Special Specifications of the work, whereupon the Contractor will be required to construct the sections, as modified in the Plans or Specifications, at the prices bid in the Proposal.

## D-3 ABBREVIATIONS AND DEFINITIONS

The following abbreviations have been used throughout these specifications:

ACI	—	American Concrete Institute
AISC	—	American Institute of Steel Construction
ANSI	—	American National Standards Institute
ASTM	—	American Society for Testing and Materials
AWS	—	American Welding Society
AWWA	—	American Water Works Association
City	—	City of Philadelphia
Engineer	—	General Manager of Planning and Engineering of the Water Department or his duly authorized representative
Inspector	—	A representative of the Engineer responsible for inspection

The following definitions have been used throughout these specifications:

- Construction — new construction and reconstruction
- Sanitary Sewer — a sewer that carries sewage only
- Combined Sewer — a sewer that carries sewage and stormwater
- Stormwater Conduit — a conduit that carries stormwater only
- Separate System — a collection system that consists of a separate stormwater conduit and a sanitary sewer

Interceptor or Intercepting Sewer — a main branch of the collection system that leads directly to another interceptor or a water pollution control plant

Standard Details for Sewers — the Philadelphia Water Department's standard details that are included with this publication

#### **D-4 REQUIREMENTS, TESTS AND INSPECTION**

All materials used in Water Department contracts for the construction of sewers and stormwater conduits shall conform to the requirements as noted in the Standard Details for Sewers, and these specifications, except where noted on the Plans or revised in the Special Specifications of the Contract.

Materials shall be obtained from suppliers on the "Lists of Approved Suppliers of Materials for Water Department Contracts". The Contractor shall submit to the Engineer his/her list of suppliers for the Contract.

All materials shall be tested for conformance to the current specifications, and in accordance with the current standard test methods, of technical societies, institutes, associations or Federal and State specifications, as called for in these specifications, in the Special Specifications of the Contract or as called for by the Engineer. Current specifications and current standard test methods are defined as the latest editions, amendments or revisions that are current at the time of receipt of bids. The Contractor shall transport, without charge, the test specimens to the Materials Testing Laboratory of the Water Department.

Construction of sewers, stormwater conduits and appurtenances shall be inspected by the Water Department. Final inspection may be made by use of a closed circuit television system. The Contractor will be required to assist the Inspector in making this inspection. See City Standard Contract Requirements for additional information regarding inspection.

#### **D-5 LINES AND GRADES**

All pipes and reinforced concrete sections shall be laid in an upstream direction to the lines and grades furnished by the Engineer. All pipes shall be laid with the bell end upgrade. All pipes and reinforced concrete sections, when laid together, shall make a continuous and uniform line with a smooth, regular interior surface.

#### **D-6 WIDTH OF TRENCHES**

The width of trenches for sewers shall be as detailed in the Standard Details for Sewers or as shown on the Plans.

#### **D-7 INSTALLATION OF PIPES**

Care shall be taken in placing the pipe into the trench to prevent damaging the joints or joint-material and to prevent disturbing the trench.

The manufacturer's recommendations for pipe assembly must be closely followed. Care must be taken to clean the mating surfaces of the joints be-

fore jointing. The jointing surfaces shall be lubricated as recommended by the manufacturer. The pipe ends shall be aligned and assembled by hand, bar or the use of a come-along. In all instances the ends of the pipe must be protected against damage.

#### **D-8 PROTECTION OF PIPES**

The mouth of the pipes, in the trenches, shall be carefully protected from blasts, rock falls or damage from any other source. In all cases the excavation shall be fully completed at least thirty feet in advance of laying the pipe. In addition, the mouth of the pipes shall be provided with means to prevent earth or any other substance from entering.

#### **D-9 LENGTH OF PIPES**

All pipes used in the construction of sewers, stormwater conduits and other connects shall be the maximum length produced, except where shorter lengths are required for closures, curved sewers or to secure proper locations for laterals or inlet connections.

#### **D-10 PROVISIONS FOR LATERAL CONNECTIONS**

Unless otherwise specified, provisions shall be made for lateral connections on each side of the sewer and/or stormwater conduit in accordance with zoning requirements, or with existing or preceding building developments.

Laterals shall be constructed to have a direct fall between the curb line and the connection at the sewer and/or stormwater conduit.

The depth of laterals at the curb line, for branch sewer projects or sewers in newly developing areas, shall be 7 feet unless otherwise specified.

The depth of laterals at the curb line, for sewer reconstruction projects, shall be as required to make the connection to the existing traps. Only laterals servicing buildings shall be connected to sewers.

#### **D-11 MEASUREMENT FOR PAYMENT**

Unless otherwise noted on the Plans or in the Special Specifications, all distances shown on the Plans are in District Standard measurements. Payment for all lengths of work will be based upon that standard.

Inlet, lateral and drain connections shall be paid for by linear measurement. No extra allowance will be made for the necessary bends and branches.

#### **D-12 FILLING ABANDONED SEWERS**

Where existing sewers are reconstructed in another location, the abandoned sewer shall be completely filled after the ends are sealed.

Abandoned sewers shall be filled through their manholes. Openings shall be made to extend laterals and to fill the sewer when manholes cannot be used. The openings for filling the sewer shall not exceed 20 square feet in

area and shall be at 30 foot intervals where no other openings are required.

Materials for filling abandoned sewers shall be 30 psi controlled density fill or 1:8 cement-sand grout unless otherwise noted on the Plans and/or in the Special Specifications for the work.

Pipes 15 inches in diameter and under are not required to be filled.

### **D-13 FILLING ABANDONED MANHOLES**

Unless otherwise noted on the Plans existing manholes on sewers to be abandoned shall be removed to 4 feet below the surface of the street. The remaining portion of the manhole shall be filled with selected earth material after the sewer is filled.

### **D-14 FILLING ABANDONED INLETS**

Where an inlet location is to be changed the existing inlet shall be abandoned and filled. The top of the existing inlet, including brick masonry and castings, shall be removed to a depth of 12 inches below the roadway paving. The cast iron trap shall be removed, the outlet pipe sealed with brick masonry and the basin of the inlet filled with selected earth material to the level of the footway paving subgrade or roadway paving subgrade. The castings shall be hauled to the Sewer Maintenance Storage Yard at 29th and Cambria Streets unless otherwise stated in the Special Specifications.

## **MATERIALS FOR THE CONSTRUCTION OF SEWERS AND APPURTENANCES**

### **D-15.0 VITRIFIED CLAY PIPE**

Vitrified clay pipe used in the construction of sewers, connections and other fittings, including bends, cut curves and wye branches, shall be extra strength clay pipe, shall conform to ASTM C 700 Standard Specification for Vitrified Clay Pipe, Extra Strength, Standard Strength and Perforated, and shall be tested in accordance with ASTM C 301 Standard Methods of Testing Vitrified Clay Pipe. Tables 1 and 2 of ASTM C 700 shall be modified to include 5 inch diameter pipe. The values for the 5 inch diameter pipe shall be the same as those shown for the 6 inch diameter pipe.

#### **D-15.1 Compression Joints**

All vitrified clay pipes used in the construction of sewers and connections shall have gasket joints. The joints and joint materials shall conform to ASTM C 425 Standard Specification for Compression Joints for Vitrified Clay Pipe and Fittings. The use of polyvinyl chloride (PVC) for the outside sheath (bell) of the compression joints will not be permitted.

#### **D-15.2 Installing Pipes**

All vitrified clay pipes shall be installed in accordance with ASTM C 12 Standard Recommended Practice for Installing Vitrified Clay Pipe Lines.

Pipe sewers in concrete cradles shall be constructed as detailed in the Standard Details for Sewers. Pipes not in concrete cradles shall have Class D bedding.

### **D-15.3 Changes in Alignment**

All changes in alignment in vitrified clay pipe sewers shall be at manholes. Manufactured and field fabricated bends are not permitted.

### **D-15.4 Connections**

Existing laterals shall be connected to vitrified clay pipe with wye branches.

Provisions shall be made for future lateral connections by the use of wye branches and stoppers. No extra or additional payment will be made for the stoppers.

All spur and inlet connections shall be made with wye branches.

## **D-16.0 REINFORCED CONCRETE PIPE**

Circular reinforced concrete pipe used in the construction of sewers and/or stormwater conduits, including wye branches, bends and fittings, shall conform to ASTM C 76 Standard Specification for Reinforced Concrete Culvert, Storm Drain and Sewer Pipe, Class III, Wall B. Quadrant reinforcing of the pipe will not be permitted.

Elliptical reinforced concrete pipe used in the construction of sewers and/or stormwater conduits, including wye branches, bends and fittings, shall conform to ASTM C 507 Standard Specification for Reinforced Concrete Elliptical Culvert, Storm Drain, and Sewer Pipe, Class HE-III or Class VE-III.

### **D-16.1 Compression Joints**

All reinforced concrete pipe used in the construction of sewers and/or stormwater conduits shall have rubber gasket joints. The joints and the gasket material shall conform to ASTM C 443 Standard Specification for Joints for Circular Concrete Sewer and Culvert Pipe, Using Rubber Gaskets. The joint shall consist of a bell or groove on one end of a unit of pipe and a spigot or tongue on the adjacent end of the joining pipe.

### **D-16.2 Installing Pipe**

After the pipes are placed in the trench, they shall be prepared for coupling by thoroughly cleaning and then lubricating the joint. For pipes manufactured to accept "O" ring gaskets, the groove and the "O" ring gasket shall be lubricated as recommended by the manufacturer. The gasket shall be placed in the groove and the tension shall be equalized by inserting a suitable tool under the gasket and running it around the pipe 3 times.

For pipes manufactured to accept fin type gaskets, the inside surface of the bell or groove and the gasket shall be lubricated as recommended by the manufacturer.

After the joint is lubricated, the pipes shall be coupled immediately. The pipes shall be pulled up tightly by using a winch, come-along or other appropriate method. A visual check shall be made to see that the pipe is properly connected.

Lift holes shall be filled with concrete. Excess concrete that falls into the pipe shall be removed before the concrete sets.

### **D-16.3 Changes in Alignment**

All changes of direction in reinforced concrete pipe that exceed allowable joint deflection shall be made with factory manufactured bends. Field fabricated bends are not permitted.

### **D-16.4 Connections**

Factory manufactured wye branches shall be used to connect intersecting reinforced concrete pipe sewers, stormwater conduits, spurs and drains to the main sewer or stormwater conduit. Field fabricated wye branches and connections are not permitted.

Inlet pipes, vent pipes and laterals, 12 inches in diameter and over, shall be connected to reinforced concrete pipe, 27 inches in diameter and under with wye branches.

Inlet pipes, vent pipes, and laterals, 12 inches in diameter and over, shall be connected to reinforced concrete pipe, 30 inches in diameter and over with wye branches or saddles.

Laterals, 10 inches in diameter and under, shall be connected to reinforced concrete pipe with saddles.

The use of a maul to create openings in the reinforced concrete pipe for saddles or inserts is not permitted. Saddle connections shall be grouted around the opening.

## **D-17.0 CAST-IN-PLACE, REINFORCED CONCRETE SEWERS, STORMWATER CONDUITS AND SPECIAL SECTIONS**

Cast-in-place, reinforced concrete sewers, stormwater conduits and special sections, such as junction chambers, intercepting chambers and flares, shall be designed and constructed as recommended by ACI 350 Concrete Sanitary Engineering Structures. The concrete shall be watertight and resistant to naturally occurring and commonly used chemicals. The concrete shall be ready-mixed and shall be batched, mixed and transported in accordance with ASTM C 94 Standard Specification for Ready-Mixed Concrete.

The reinforcing shall be deformed steel bars that are rolled from new billet-steel and shall conform to ASTM A 615 Standard Specification for Deformed and Plain Billet-Steel Bars for Concrete Reinforcement. The bars shall be tested in accordance with ASTM A 370 Standard Methods and Definitions for Mechanical Testing of Steel Products. Bar sizes up to #6 may be Grade 40. Bar sizes #7 through #11 shall be Grade 60. Grade 40 and Grade 60



reinforcing bars shall not be mixed for main steel. Grade 60 shall take precedence.

### **D-17.1 Construction Joints**

Longitudinal construction joints shall be used in the sidewalls. Transverse construction joints shall be constructed at the end of each section at a distance not to exceed 50 feet. Transverse and longitudinal construction joints shall have a keyway 2 inches deep and 4 inches wide and a rubber dumbbell type waterstop.

### **D-17.2 Rubber Dumbbell Type Waterstops**

The material used for rubber dumbbell type waterstops shall be formulated from styrene-butadiene rubber (SBR) and shall conform to the following:

Hardness — Shore A durometer hardness shall be 60 to 70.

Elongation — The elongation shall be a minimum of 450%.

Tensile Strength — The strength shall be a minimum of 2500 pounds per square inch.

Tensile Strength After Aging — The tensile strength of the test specimen, after an accelerated aging test of 7 days at 158°F, shall be not less than 80% of original tensile strength. The tensile strength of the test specimen, after an accelerated aging test of 94 hours  $\pm$  1/2 hour in oxygen at 158°F  $\pm$  1.8°F and 300 pounds per square inch, shall be not less than 80%.

Water Absorption — The water absorption shall be a maximum of 5% by weight after immersion in water for 7 days at 73.4°  $\pm$  2°F.

Compression Set — The compression set after 22 hours at 158°F shall be not more than 30%.

Testing shall be in accordance with Federal Test Method Standard No. 601 and with ASTM D 395, Standard Test Methods for Rubber Property — Compression Set, Method B.

#### **D-17.2.1 Installation of Waterstops**

Waterstops shall be installed as recommended by ACI 504 Guide to Joint Sealants for Concrete Structures and as follows.

Waterstops shall be securely held in position so that they are not displaced during concreting operations. Care shall be taken when placing and consolidating the concrete so that voids or honeycombing do not occur adjacent to waterstops. Care shall also be taken to avoid tearing waterstops and to keep waterstops from being contaminated with dirt, form coatings or other foreign substances.

Waterstops shall be made continuous with splices. Intersecting waterstops shall be spliced together. Lapping of waterstops will not be accepted

under any circumstances. Splices shall be made by one of the following methods.

Method 1: Prepare the waterstops by mitering, cleaning and then roughening the joining ends. Cement and join the waterstops and hold the joint in a mold under the heat and pressure prescribed by the manufacturer until cured (vulcanized).

Method 2: Prepare the waterstops by cleaning and roughening the joining ends. Coat the ends with cement and then insert them into a premolded sleeve or fitting.

Under both Methods 1 and 2 the Contractor shall use the cements, heat tools, fittings and procedures as prescribed by the manufacturer of the waterstops.

### **D-17.3 Inverts**

The invert of rectangular reinforced concrete sewers shall be constructed with a 156° vee shape at 12° off the the horizontal. Rectangular reinforced concrete stormwater conduits shall be constructed with flat inverts.

Steel troweled concrete inverts may be used for velocities of flow from 2-1/2 feet per second to 12 feet per second inclusive. For velocities of flow between 12 feet per second and 15 feet per second vitrified clay liner plates, stone block or redressed blocks shall be used in the invert. Under no circumstances shall velocities of flow exceed 15 feet per second for full flows.

It is extremely important to maintain lines and grades and to avoid dips.

#### **D-17.3.1 Vitrified Clay Liner Plates**

All vitrified clay liner plates used for the invert of sewers and stormwater conduits shall be manufactured and tested in accordance with ASTM C 479 Standard Specification for Vitrified Clay Liner Plates.

All liner plates shall be laid true to line and grade. Where applicable, curved liner plates shall be used at and along the center line of the section. Liner plates shall be laid long side parallel to the centerline in stretcher bond arrangement (staggered joints). The joints between the plates shall not exceed 3/16 inch and shall be filled with an acid resistant mortar as described in Section D-17.3.4, struck smooth, after the plates are set.

#### **D-17.3.2 Stone Blocks**

A stone block invert shall consist of granite or trap rock block with square heads and sides as follows: depth, 6 to 7 inches; length, 10 to 14 inches; width, 3-1/2 to 5 inches. The block shall be sorted at the quarry and delivered in a uniform size. All faces of the block shall be true, parallel, not warped and free from lumps, protuberances, depressions and inequalities exceeding 1/4 inch. Blocks of equal width shall be laid in a continuous course. Worn paving

blocks shall not be used. The joints between the blocks shall be filled with an acid resistant mortar as described in Section D-17.3.4, struck smooth, after the blocks are set.

#### **D-17.3.3 Redressed Blocks**

Redressed granite blocks shall consist of selected granite blocks cut or split to the dimensions required below and so dressed as to have the top and side faces substantially rectangular in shape in order to form, when laid, end and side joints not exceeding 1/2 inch in width.

The blocks after dressing shall be 5 to 6-1/2 inches in length, 3-1/2 to 5 inches in width and shall have a depth of 4-3/4 to 5-1/4 inches, averaging 5 inches as determined by gauging at the time of cutting. Blocks shall not vary in depth by more than 1/2 inch. The heads of the blocks shall not show irregularities after redressing exceeding 3/8 of an inch.

The joints between the blocks shall be filled with an acid resistant mortar as described in Section D-17.3.4, struck smooth, after the blocks are set.

#### **D-17.3.4 Mortar**

The acid resistant mortar shall be a potassium silicate liquid binder and shall be manufactured and tested in accordance with ASTM C 466 Standard Specification for Chemically Setting Silicate and Silica Chemical-Resistant Mortars.

The invert shall be cleaned of all excess mortar before the sewer or stormwater conduit is put into service.

### **D-18.0 PRECAST, REINFORCED CONCRETE SEWERS AND STORMWATER CONDUITS**

Precast reinforced concrete sections used in the construction of sewers and/or stormwater conduits, including bends and other fittings, shall conform to ASTM C 789 Standard Specification for Precast Reinforced Concrete Box Sections for Culverts, Storm Drains and Sewers.

#### **D-18.1. Joints**

All precast reinforced concrete box sections shall have tongue and groove or lap joints. The joints shall be made so that when the sections are laid together they will form a continuous line with a smooth interior that is free of appreciable irregularities.

The material used in the joints shall be non-porous and not affected by materials found in sewage. Joints shall be designed to prevent infiltration and exfiltration. The manufacturer shall furnish the City with a detailed design of the watertight joint to be used. The manufacturer shall furnish the City and the Contractor with proper handling, storage and installation procedures.

### **D-18.1.1 Performance Requirements for Joints**

The City will require that assembled joints pass the following performance tests without leakage at the joints.

- A. Box Sections in Straight Alignment — Hydrostatic pressure tests on joints shall be made on the assembly of two box sections, properly connected in accordance with the joint design. A second such test may be required. Suitable bulkheads may be provided within the box section adjacent to and on either side of the joint, or the outer ends of the two joined box sections may be bulkheaded. No mortar or concrete coatings, fillings, or packings shall be placed prior to watertightness tests. After the box sections are fitted together with the proper joint design in place, the assembly shall be subjected to an internal hydrostatic pressure of 13 psi (90 kPa) (30 ft.) (9.14 m) pressure head for 10 min. Moisture or beads of water appearing on the surface of the joint will not be considered as leakage. If leakage of the joints should initially occur, the manufacturer shall have the option to extend the test period up to 24 hours.
- B. Box Sections in Maximum Deflected Position — Upon completion of the test for box section in straight alignment, the test sections shall be deflected to create a position 1/2 in. (12.7 mm) wider than the assembled position on one side of the outside perimeter of the joint and shall be subjected to an internal hydrostatic pressure of 10 psi (69 kPa) for 10 min. Moisture or beads of water appearing on the surface of the joint will not be considered as leakage.

### **D-18.1.2 Additional Requirements**

Additional joint requirements shall apply as they are developed and/or recognized by the City.

### **D-18.2 Inverts**

The inverts of precast rectangular reinforced concrete sewers shall be constructed with a 156° vee shape at 12° off the horizontal. Precast rectangular reinforced concrete stormwater conduits shall be constructed with flat inverts.

## **D-19.0 DUCTILE IRON PIPE**

Ductile iron pipe used in the construction of sewers, including bends, wye branches and other fittings, shall be manufactured and tested in accordance with the American National Standard for Ductile Iron Pipe, Centrifugally Cast in Metal Molds or Sand Lined Molds, for Water or Other Liquid, ANSI A21.51 (AWWA C151).

In addition to the standard acceptance test specified in ANSI-A21.51 (AWWA C151), the manufacturer shall perform either the ball impression test or the ring test to ascertain and assure the ductility of the pipe.

Unless otherwise noted in the Special Specifications the pipe shall be Class 56 for pipe 12" in diameter and smaller and Class 54 for pipe larger

than 12" in diameter. The interior of the pipes and fittings shall be cement lined and seal coated. The exterior of the pipes and fittings shall be bituminous coated. The cement lining and coating shall be in accordance with the American National Standard for Cement-Mortar Lining for Cast Iron and Ductile Iron Pipe and Fittings for Water, ANSI A21.4 (AWWA C104) and shall be 1/8 inch thick for pipe sizes 3 inches diameter to 12 inches diameter inclusive.

#### **D-19.1 Compression Joints**

All ductile iron pipes and fittings used in the construction of sewers, including bends and wye branches shall have gasket joints. Unless otherwise noted in the Special Specifications, the pipe and fittings shall have push on joints.

The gaskets shall be manufactured and tested in accordance with the American National Standard for Rubber-Gasket Joints for Cast Iron and Ductile Iron Pressure Pipes and Fittings, ANSI A21.11 (AWWA C111).

The outside edges of field cut pipes and fittings shall be beveled back 1/8 inch from the cut edges on a 30 degree angle in order to avoid damaging the gasket.

#### **D-19.2 Installing Pipe**

The pipe shall be installed as described in the Ductile Iron Pipe Research Association's "Guide for the Installation of Ductile Iron Pipe".

### **D-20.0 CAST IRON SOIL PIPE**

Where called for on the Plans or where directed by the Engineer, cast iron soil pipe shall be used for laterals, vent pipes, and inlet connections. The cast iron soil pipe shall be manufactured and tested in accordance with ASTM A 74 Standard Specification for Cast Iron Soil Pipe and Fittings, Service Size, Single Hub. The pipe shall have nominal laying lengths of 5 feet and 10 feet for all size diameters.

#### **D-20.1 Compression Joints**

Joints in cast iron soil pipes and fittings shall be sealed with pre-formed rubber gaskets. The gaskets shall be manufactured and tested in accordance with ASTM C 564 Standard Specification for Rubber Gaskets for Cast Iron Soil Pipe and Fittings.

### **D-21.0 MANHOLES**

Manholes shall be brick, cast-in-place concrete, or precast reinforced concrete manhole sections. Manholes built into sanitary sewers with inverts below elevation 0.00 City datum or into any intercepting sewers shall be restricted to cast-in-place concrete or precast reinforced concrete sections.

Manholes shall be constructed with steps and/or ladder bars from the invert of the sewer or stormwater conduit to the top of the manhole.

Manholes built into sanitary sewers or combined sewers shall be fitted with cast iron frames and closed covers. Manholes built into stormwater conduits shall be fitted with cast iron frames and solid or vented covers.

#### **D-21.1.1 Brick Manholes**

Brick used for manholes shall be manufactured in accordance with ASTM C 32 Standard Specification for Sewer and Manhole Brick (Made from Clay or Shale) and tested in accordance with ASTM C 67 Standard Method of Sampling and Testing Brick and Structural Clay Tile. The bricks used for manholes shall be grade MS.

#### **D-21.1.2 Cast-in-Place Concrete Manholes**

Cast-in-place concrete manholes shall be built according to the Plans and Special Specifications. The concrete shall be in accordance with ASTM C 94 Standard Specification for Ready-Mix-Concrete, Alternate 2.

#### **D-21.1.3 Precast Reinforced Concrete Manholes**

Precast reinforced concrete manhole sections, including grade rings, eccentric cones, riser sections and base sections, shall comply with ASTM C478 Standard Specification for Precast Reinforced Concrete Manhole Sections, and shall be tested and registered with the Quality Certification Staff in accordance with the Quality Certification Standard QC-1 for Precast Concrete Products. In addition, manufacturers must be certified in accordance with QC-1 by the Quality Certification Staff and shop drawings must be approved by the Water Department Design Branch.

Precast reinforced concrete manholes built into sanitary, combined and intercepting sewers shall have rubber gasket joints which shall conform to ASTM C 443 Standard Specification for Joints for Circular Concrete Sewer and Culvert Pipe, Using Rubber Gaskets. Precast reinforced concrete manholes built into stormwater conduits shall have rubber gasket joints or mortar joints.

Resilient connectors shall be used to insert pipe into precast reinforced concrete manholes that are built into sanitary sewers with inverts below elevation 0.00 City datum or into any intercepting sewers. Resilient connectors shall meet the requirements of ASTM C 923 Standard Specification for Resilient Connectors Between Reinforced Concrete Manhole Structures and Pipes and must be approved by the Water Department Design Branch prior to use.

Joints between pipes and precast reinforced concrete manholes that are built into combined sewers that are not intercepting sewers, sanitary sewers above elevation 0.00 City datum or stormwater conduits, shall be sealed with non-shrink, non-metallic mortar. The mortar shall meet the requirements of Section D-23.8, paragraph 3.

In addition to the requirements specified in ASTM C478, the concrete mix shall meet the following: The minimum compressive strength shall be 4,000

psi. The water-cement ratio shall be 0.45. The minimum cement content shall be 564 lb./cu. yd. The cement shall be Portland Cement Type I, IA, II, IIA, III or IIIA. The slump shall be 3 inches maximum and 1 inch minimum. The air content shall be  $6 \pm 1\%$ . Air-entraining admixtures must meet the requirements of ASTM C 260 Standard Specification for Air-Entraining Admixtures for Concrete. Coarse aggregate shall be No. 67 or No. 57.

### **D-21.2. Ladder Bars and Steps**

The materials for ladder bars and steps shall be as follows.

#### **D-21.2.1 Aluminum**

Aluminum for manhole steps shall be manufactured and tested in accordance with ASTM B 221 Standard Specification for Aluminum-Alloy Extruded Bars, Rods, Wire, Shapes and Tubes, Alloy 6061 T6. Embedded ends of aluminum steps shall have 2 coats of bitumastic.

#### **D-21.2.2 Ductile Iron**

Ductile iron manhole steps and ladder bars shall be manufactured and tested in accordance ASTM A 536 Standard Specification for Ductile Iron Castings, Grade 60-40-18.

#### **D-21.2.3 Plastic**

Plastic manhole steps shall be No. 4 deformed steel reinforcing bars encapsulated within a molding of copolymer polypropylene.

Steel reinforcing bars shall be grade 60, rolled from new billet-steel and shall conform to ASTM A 615 Standard Specification for Deformed and Plain Billet-Steel Bars for Concrete Reinforcement and shall be tested in accordance with ASTM A 370 Methods and Definitions for Mechanical Testing of Steel Products.

The plastic encasement shall be manufactured and tested in accordance with ASTM D 2146 Standard Specification for Propylene Plastic Molding and Extrusion Materials, Type II-49108-D.

### **D-21.3 Manhole Frames and Covers**

Manhole frames and covers shall be tested and registered with the Quality Certification Staff in Accordance with the Quality Certification Standard QC-2 for Gray Iron Castings. In addition, manufacturers must be certified in accordance with QC-2 by the Quality Certification Staff and shop drawings must be approved by the Water Department Design Branch.

Manhole frames and covers shall be made of Class 30B gray iron which is tested in accordance with ASTM A 48 Standard Specification for Gray Iron Castings. The name of the foundry and the heat and lot number shall be cast into the frame and into the exterior side of the cover.

Manholes frames and covers shall be thoroughly cleaned. All projections and roughness shall be ground smooth. The bearing surfaces of the frame and cover shall not rock or jam. Frames and covers shall not be painted.

## **D-22.0 WELLHOLES**

Wellholes, including the base and the portion that contains the drip slabs or rings, shall be cast-in-place concrete or precast reinforced concrete manhole sections. Cast-in-place wellholes shall have brick or precast reinforced concrete manhole risers and cones. Precast wellholes shall have precast reinforced concrete manhole risers and cones.

Manholes ladder bars and/or steps shall be constructed from the highest drip slab or drip ring to the top of the wellhole. Two epoxy coatings (see Section D-22.5) shall be applied to the drip slabs or drip rings and to the inside surface of the wellhole.

Wellholes built into combined sewers shall be fitted with gray iron frames and closed covers. Wellholes built into stormwater conduits shall be fitted with gray iron frames and solid or vented covers.

### **D-22.1. Concrete Wellholes**

Cast-in-place concrete wellholes shall have precast reinforced concrete drip slabs as described in Section D-22.4. Brick risers and cones shall be built to the dimensions shown in the standard detail for Brick Manhole: Riser and Cone and shall meet the requirements of Section D-21.1.1.

### **D-22.1.2 Precast Reinforced Concrete Wellholes**

Precast reinforced concrete wellholes, including risers and cones, shall be constructed from precast reinforced concrete manhole sections as described in Section D-21.1.3 and as shown in standard detail for Precast Concrete Manhole: Riser and Cone. Precast wellholes shall have precast reinforced concrete drip rings as described in Section D-22.4.

Precast reinforced concrete wellholes shall have rubber gasket joints which shall conform to ASTM C 443 Standard Specification for Joints for Circular Concrete Sewer and Culvert Pipe, Using Rubber Gaskets.

### **D-22.2 Ladder Bars and Steps**

Wellhole ladder bars and steps shall be of the same size, configuration and materials as manhole ladder bars and steps and shall conform to Sections D-21.2 to D-21.2.3.

### **D-22.3 Wellholes Frames and Covers**

Wellholes frames and covers shall consist of manhole frames and covers and shall conform to Section D-21.3.

### **D-22.4 Drip Slabs and Drip Rings**

Drip slabs and drip rings shall be precast reinforced concrete, shall com-



ply with ASTM C 478 Standard Specification for Precast Reinforced Concrete Manhole Sections and shall be certified and registered with the Quality Certification Staff in accordance with the Quality Certification Standard QC-1 for Precast Concrete Products. In addition, manufacturers must be certified in accordance with QC-1 by the Quality Certification Staff and shop drawings must be approved by the Water Department Design Branch.

In addition to the requirements specified in ASTM C 478, the concrete mix shall meet the following: The minimum compressive strength shall be 5,000 psi. The water-cement ratio shall be 0.45. The minimum cement content shall be 564 lb./cu.yd. The cement shall be Portland Cement Type I, IA, II, IIA, III or IIIA. The slump shall be 3 inches maximum and 1 inch minimum. The air content shall be  $6\% \pm 1\%$ . Air-entraining admixtures must meet the requirements of ASTM C 260 Standard Specification for Air-Entraining Admixtures for Concrete. Coarse aggregate shall be No. 67.

### **D-22.5 Epoxy Coating**

The entire inside surface of the wellhole, from and including the wellhole invert to 2 feet above the crown of the top entrance pipe, shall be given two coats of an epoxy coating such as Sikagard 62 or an approved equal. The epoxy coating shall be a solvent free, 100% solids, epoxy resin that dries to a hard, tile-like finish. Each coat shall be a different color. The final coat shall be gray or white.

Precast reinforced concrete wellhole sections, including risers, bases, drip slabs and drip rings, shall be coated by the precast manufacturer after the concrete has cured for the amount of time recommended by the epoxy manufacturer and for a minimum of 3 weeks. The Contractor shall repair any chips, cracks or abrasions in the coating that occur during installation by applying 2 additional coats to the effected area.

Poured-in-place concrete wellholes shall be coated by the Contractor after the concrete has cured for the amount of time recommended by the epoxy manufacturer and for a minimum of 3 weeks. If the wellhole has been in use then the Contractor shall flume the flow, clean the wellhole as recommended by the manufacturer, apply the epoxy coating and shall continue to flume the flow until the coating has cured. If the wellhole has not been in use, the epoxy coating shall be applied by the Contractor and allowed to cure before the wellhole is put in service.

### **D-23.0 INLETS**

Inlets shall not be built until the locations are approved at the site.

The use of 90° bends in the pipe connection between the inlet and the sewer is prohibited.

### **D-23.1 Catch Basins**

Inlet catch basins shall be brick, cast-in-place concrete, or precast reinforced concrete.

All inlet catch basins shall have gray iron traps which may be placed in any wall as required.

#### **D-23.1.1 Brick Catch Basins**

Brick used to construct inlet catch basins shall conform to ASTM C 32 Standard Specification for Sewer and Manhole Brick (Made From Clay or Shale) and shall be tested in accordance with ASTM C 67 Standard Methods of Sampling and Testing Brick and Structural Clay Tile. Brick shall be Grade MS.

#### **D-23.1.2 Concrete Catch Basins**

Cast-in-place concrete inlets shall have interior and exterior formwork. The concrete shall have a minimum compressive strength of 2,500 psi and shall be made with Portland Cement Type I, IA, II, IIA, or, when specified, Type III or IIIA. The concrete shall be manufactured in accordance with ASTM C 94 Standard Specification for Ready-Mixed Concrete.

#### **D-23.1.3 Precast Reinforced Concrete Catch Basins**

Precast reinforced concrete catch basins shall comply with ASTM C 913 Standard Specification for Precast Concrete Water and Wastewater Structures and shall be tested and registered according to the Quality Certification Standard QC-1 for Precast Concrete Products. In addition, manufacturers must be certified in accordance with QC-1 by the Quality Certification Staff and shop drawings must be approved by the Water Department Design Branch.

In addition to the requirements specified in ASTM C 913, the concrete mix shall meet the following: The minimum compressive strength shall be 4,000 psi. The water-cement ratio shall be 0.45. The minimum cement content shall be 564 lb./cu. yd. The cement shall be Portland Cement Type I, IA, II, IIA, III or IIIA. The slump shall be 3 inches maximum and 1 inch minimum. The air content shall be 6%  $\pm$  1%. Admixtures, other than air-entraining, must be approved prior to use. Coarse aggregate shall be No. 67 or 57.

The reinforcing shall be as described in ASTM C 913. The welded wire fabric used for reinforcing shall be the sheet type.

#### **D-23.2 Precast Reinforced Concrete Hood**

Precast reinforced concrete hoods shall conform to ASTM C 913 and QC-1 as stated in Section D-23.1.3. Manufacturers shall also be certified in accordance with QC-1 by the Quality Certification Staff and shop drawings must be approved by the Water Department Design Branch.

The concrete mix shall conform to the requirements stated in Section D-23.1.3.

The reinforcing shall be in accordance with ASTM A 615 Standard Specification for Deformed and Plain Billet-Steel Bars for Concrete Reinforcement, Grade 40.

### **D-23.3 Precast Reinforced Concrete City Inlet Top Slabs**

Precast reinforced concrete City Inlet top slabs shall conform to ASTM C 913 and QC-1 as stated in Section D-23.1.3. Manufacturers shall also be certified in accordance with QC-1 by the Quality Certification Staff and shop drawings must be approved by the Water Department Design Branch.

The concrete mix shall conform to the requirements stated in Section D-23.1.3 except that coarse aggregate shall be No. 67 only.

The reinforcing shall be in accordance with ASTM A 615 Standard Specification for Deformed or Plain Billet-Steel Bars for Concrete Reinforcement, Grade 40.

Reinforcing bars shall be welded to other bars and to the steel channel as shown in the Standard Details for Sewers. Welds shall be in accordance with Section 1.17 of the AISC Specifications for the Design, Fabrication and Erection of Structural Steel for Buildings. Welders shall be qualified as required by the AWS to perform the type of work required.

#### **D-23.3.1. Curb Nosing**

The curb nosing shall be a self-weathering steel channel and shall conform to ASTM A 242 Standard Specification for High-Strength Low Alloy Structural Steel or ASTM A 588 Standard Specification for High-Strength Low Alloy Structural Steel With 50 ksi Minimum Yield Point to 4 inches Thick.

#### **D-23.3.2 Lifting Inserts**

Lifting inserts shall fit a 3/4 inch eye bolt and shall be type LP-4 as manufactured by Richmond Screw Anchor Company or an approved equal. Inserts shall be welded to the reinforcing bars.

### **D-23.4 Precast Reinforced Concrete Inlet Adjustment Risers**

Precast reinforced concrete inlet adjustment risers for Open Mouth Inlets and Highway Grate Inlets shall conform to ASTM C 913 and QC-1 as stated in Section D-23.1.3. Manufacturers shall also be certified in accordance with QC-1 by the Quality Certification Staff and shop drawings must be approved by the Water Department Design Branch.

The concrete mix shall conform to the requirements stated in Section D-23.1.3

The reinforcing shall be as described in ASTM C 913.

### **D-23.5 Traps**

Traps shall be tested and registered with the Quality Certification Staff in accordance with the Quality Certification Standard QC-2 for Gray Iron Castings. In addition, manufacturers must be certified in accordance with QC-2 by the Quality Certification Staff and shop drawings must be approved by the Water Department Design Branch.

Traps shall be made of Class 30B gray iron which is tested in accordance with ASTM A 48 Standard Specification for Gray Iron Castings.

The name of the foundry and the heat and lot number shall be cast into the face of the clean-out door and into the body of the trap.

The trap shall be thoroughly cleaned. All projections and roughness shall be ground smooth. Traps shall not be painted.

#### **D-23.5.1 Appurtenances**

The neoprene gasket shall be attached to the cleanout door by 4 screws as shown in the Standard Details for Sewers or by a neoprene adhesive such as Neoprene Adhesive F-1 manufactured by Carboline, St. Louis, MO or an approval equal. The adhesive shall be specifically made for bonding neoprene to metals.

#### **D-23.6 Grates and Frames**

Inlet grates and frames shall be gray iron or structural steel. Gray iron grates and steel grates shall be interchangeable.

Gray iron used to make grates and frames shall meet the requirements of Section D-23.5. The name of the foundry and the heat and lot number shall be cast into the frame and the top of the grate.

Steel used to fabricate grates and frames shall conform to ASTM A 36 Standard Specification for Structural Steel. Welds shall be in accordance with Section 1.17 of the AISC Specifications for the Design, Fabrication and Erection of Structural Steel for Buildings. Welders shall be qualified as required by the AWS to perform the type of work required.

#### **D-23.7 Clean-Out Covers and Frames**

Inlet clean-out covers and frames shall be manufactured from gray iron that meets the requirements of Section D-23.5. The name of the foundry and the heat and lot number shall be cast into the frame and into the exterior side of the cover.

#### **D-23.8 Installation of Precast Inlets**

After excavation has been completed, level off the area where the base section will be located. Provide a 3/4" crushed stone bed to obtain a level and solid foundation. Do not use wood, brick or other materials to shim the base section.

When installing a 2 piece catch basin remove all foreign materials such as dirt, mud and stones from the joint surfaces. Apply a bitumen-type sealing compound to seal the joint. The sealing compound shall be approved by the Water Department Design Branch prior to application.

Seal all lifting holes and the adjustment area around the trap with non-shrink, non-metallic mortar. The mortar shall not contain gas-forming agents and shall be tested in accordance with ASTM C 827 Standard Test Method for Early Volume Change of Cementitious Mixtures, C 191 Standard Test Method for Time Setting of Hydraulic Cement by Vicat Needle and C 109 Standard Test Method for Compressive Strength of Hydraulic Cement Mor-

tars. The change in volume shall be 0 or shall increase slightly. The time of set shall be 45 minutes minimum. The minimum compressive strength shall be 6000 psi at 28 days.

Shut the clean-out door of the trap and secure the wedge.

The hood, adjustment risers, top slab and the grate frame shall be adjusted to the sidewalk or street grade with paving bricks and mortar. Maintain a minimum opening of 3 inches in the mouth of the inlet. If necessary, dish the street around the mouth or grate of the inlet to provide the minimum opening.

Backfill shall be deposited in layers of 8 inches or less and tamped. Compaction of the backfill through puddling is not allowed.

The work area shall be restored to its original or better condition. Restoration includes, but is not limited to, repairs or replacement of footway and curbing that is cracked or broken by the Contractor and replacing brick in brick footways.

## **D-24.0 CHAIN LINK FENCE**

Chain link fences shall be erected on headwalls and endwalls as shown in the Standard Details for Sewers or as detailed on the Plans. The fence shall be placed by means of sleeves.

### **D-24.1 Fabric**

The fence fabric shall be aluminum alloy and shall conform to ASTM B 211 Standard Specification for Aluminum-Alloy Bars, Rods and Wires, Alloy 6061, Temper T94. The wire diameter shall be 0.148 inch. The fabric shall be made up of individual wire pickets, free of splices, woven throughout to form a uniform mesh. The height of the fabric shall be as shown on the drawings and shall have knuckled selvages on the top and bottom. The mesh shall be 2 inches as measured from inside to inside, at right angles to the wire.

### **D-24.2 Posts and Rails**

Pipes for posts, top rails, bottom rails and brace rails shall be manufactured of aluminum using ANSI Schedule 40 pipe having plain ends. The aluminum pipe shall be in accordance with ASTM B 241 Standard Specification for Aluminum-Alloy Seamless Pipe and Seamless Extruded Tube, Alloy 6063, Temper T6.

#### **D-24.2.1 Posts**

Corner and end posts shall be 2-1/2 inches in diameter and shall be fitted with post caps to exclude moisture from the post.

Line and center posts shall be 2 inches in diameter and shall be fitted with post tops which are formed to allow top rails to pass through.

### **D-24.2.2. Rails**

Top rails, bottom rails and brace rails shall be 1-1/4 inches in diameter.

Brace rails shall be provided at all end and corner posts, midway between the top and bottom rail and shall extend from the end or corner post to the adjacent line posts.

Bottom rails and brace rails shall be fastened to the end, corner and line posts by means of rail ends, brace ends and brace bands. Truss rods shall be trussed between the brace end of the brace rail and the bottom rail.

Top rails shall be furnished in 20 foot lengths or as detailed on the Plans, with coupling or expansion devices to join the top rail lengths to form a continuous brace for the length of fence. Top rails shall be securely fastened to the end or corner posts by means of rail ends and brace ends.

### **D-24.2.3 Rail Ends and Post Cap Fittings**

Rail ends and post cap fittings shall be of the sizes necessary for the rails and post. They shall be aluminum and conform to ASTM B 26 Standard Specification for Aluminum-Alloy Sand Castings, Alloy SG70A, Temper T6.

### **D-24.2.4 Truss Rods and Fabricated Turnbuckles**

Truss rods and fabricated turnbuckles shall be aluminum and shall conform to ASTM B 211 Standard Specification for Aluminum-Alloy Bars, Rods and Wire, Alloy 6061, Temper T6.

### **D-24.2.5 Nuts and Bolts**

Nuts and bolts shall be aluminum. Nuts shall conform to ASTM F 467 Standard Specification for Non-Ferrous Nuts for General Use, Aluminum Alloy 6061, Temper T6. Bolts shall conform to ASTM F 468 Standard Specification for Non-Ferrous Bolts, Hex Cap Screws and Studs for General Use, Aluminum Alloy 2024, Temper T4. The bolts shall be 5/16 inch diameter.

### **D-24.2.6 Fasteners**

The fence fabric shall be securely fastened to the line posts, top rails, bottom rails and bracer rails with fabric wires spaced not more than 24 inches apart. The fence fabric shall be attached to the end post or corner posts by means of a stretcher bar threaded through the mesh fabric and using stretcher bar bands around the posts and stretcher bars.

Stretcher bars shall be aluminum, 1/4 inch thick and 3/4 inch wide. Stretcher bars shall have square edges.

Stretcher bar bands and bracer bands shall be aluminum 1/8 inch thick and 7/8 inch wide. Stretcher bar bands shall have bevelled edges. Bolts 3/8 inch diameter and 1-1/2 inches long shall be furnished with the stretcher bar bands and bracer bar bands. These bolts shall be non-removable.

The stretcher bar bands shall conform to ASTM B 221 Standard Specification for Aluminum-Alloy Extruded Bars, Rods, Wire, Shapes, and Tubes, Alloy 6063, Temper T6.

The fabric tie wire shall be aluminum conforming to ASTM B 211 Alloy 110-H18. The bolts shall be Alloy 2024, Temper T4.

#### **D-24.3 Sleeves**

The sleeves shall be aluminum and shall conform to ASTM B 241 Standard Specification for Aluminum-Alloy Seamless Pipe and Seamless Extruded Tube, Alloy 6063, Temper T6. The sleeve shall be 3-1/2 inches diameter and the outside surface shall have two (2) coats of bitumastic.