

D.I. FITTINGS

Appendix

VII

a – Weight of Ductile Iron Fittings

- [Crosses](#)
 - [Tees](#)
 - [Bends](#)
 - [Offsets](#)
 - [Reducers](#)
 - [Sleeves](#)
 - [Caps and Plugs](#)
-

MECHANICAL JOINT CROSSES

RUN in.	BRANCH in.	WEIGHT lbs.	"H" in.	"T" in.	"J" in.	"T1" in.	MATERIAL	RATING psi	SOURCE
3	3	33	4.00	0.34	4.00	0.34	25	250	C153
4	3	38	4.00	0.34	4.00	0.34	25	250	C153
4	4	42	4.00	0.34	4.00	0.34	25	250	C153
6	3	58	4.00	0.36	5.00	0.34	25	250	C153
6	4	62	4.00	0.36	5.00	0.34	25	250	C153
6	6	72	5.00	0.36	5.00	0.36	25	250	C153
8	4	84	4.00	0.38	6.50	0.34	25	250	C153
8	6	105	5.00	0.38	6.50	0.36	25	250	C153
8	8	108	6.50	0.38	6.50	0.38	25	250	C153
10	4	98	4.00	0.40	7.50	0.34	25	250	C153
10	6	110	5.00	0.40	7.50	0.36	25	250	C153
10	8	138	6.50	0.40	7.50	0.38	25	250	C153
10	10	144	7.50	0.40	7.50	0.40	25	250	C153
12	4	115	4.00	0.47	8.75	0.34	25	250	C153
12	6	129	5.00	0.47	8.75	0.36	25	250	C153
12	8	258	6.50	0.47	8.75	0.38	25	250	C153
12	10	180	7.50	0.47	8.75	0.40	25	250	C153
12	12	214	8.75	0.47	8.75	0.47	25	250	C153
16	6	250	5.00	0.50	11.50	0.36	DI	350	C153
16	8	264	6.50	0.50	11.50	0.38	DI	350	C153
16	10	287	7.50	0.50	11.50	0.40	DI	350	C153
16	12	310	8.75	0.50	11.50	0.47	DI	350	C153
16	14	363	11.50	0.50	11.50	0.50	DI	350	C153

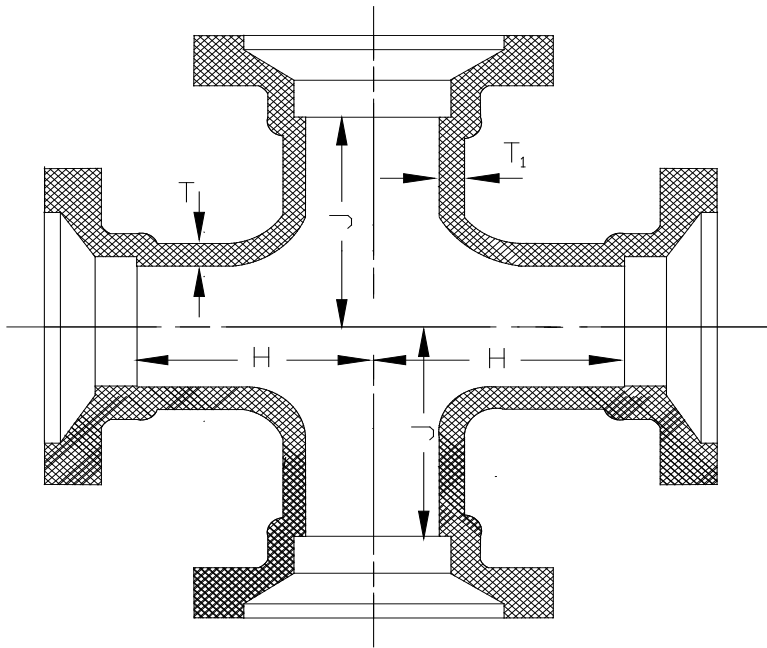

MECHANICAL JOINT CROSSES
(CONTINUED)

RUN in.	BRANCH in.	WEIGHT lbs.	"H" in.	"T" in.	"J" in.	"T1" in.	MATERIAL	RATING psi	SOURCE
16	16	410	11.50	0.50	11.50	0.70	DI	350	C153
18	6	625	13.00	0.75	15.50	0.55	DI	350	C110
18	8	655	13.00	0.75	15.50	0.60	DI	350	C110
18	10	685	13.00	0.75	15.50	0.68	DI	350	C110
18	12	725	13.00	0.75	15.50	0.75	DI	350	C110
18	14	870	16.50	0.75	16.50	0.66	DI	350	C110
18	16	930	16.50	0.75	16.50	0.70	DI	350	C110
18	18	995	16.50	0.75	16.50	0.75	DI	350	C110
20	6	760	14.00	0.80	14.00	0.55	DI	350	C110
20	8	790	14.00	0.80	17.00	0.60	DI	350	C110
20	10	820	14.00	0.80	17.00	0.68	DI	350	C110
20	12	860	14.00	0.80	17.00	0.75	DI	350	C110
20	14	905	14.00	0.80	17.00	0.66	DI	350	C110
20	16	1,085	18.00	0.80	18.00	0.70	DI	350	C110
20	18	1,155	18.00	0.80	18.00	0.75	DI	350	C110
20	20	1,230	18.00	0.80	18.00	0.80	DI	350	C110
24	6	1,025	15.00	0.89	19.00	0.55	DI	350	C110
24	8	1,045	15.00	0.89	19.00	0.60	DI	350	C110
24	12	1,260	15.00	0.89	19.00	0.75	DI	350	C110
24	16	1,375	15.00	0.89	19.00	0.70	DI	350	C110
24	20	1,450	22.00	0.89	22.00	0.80	DI	350	C110
24	24	1,835	22.00	0.89	22.00	0.89	DI	350	C110
30	12	1,865	18.00	1.03	23.00	0.75	DI	250	C110
30	24	2,675	18.00	1.03	23.00	0.89	DI	250	C110
30	30	3,075	18.00	1.03	23.00	1.03	DI	250	C110

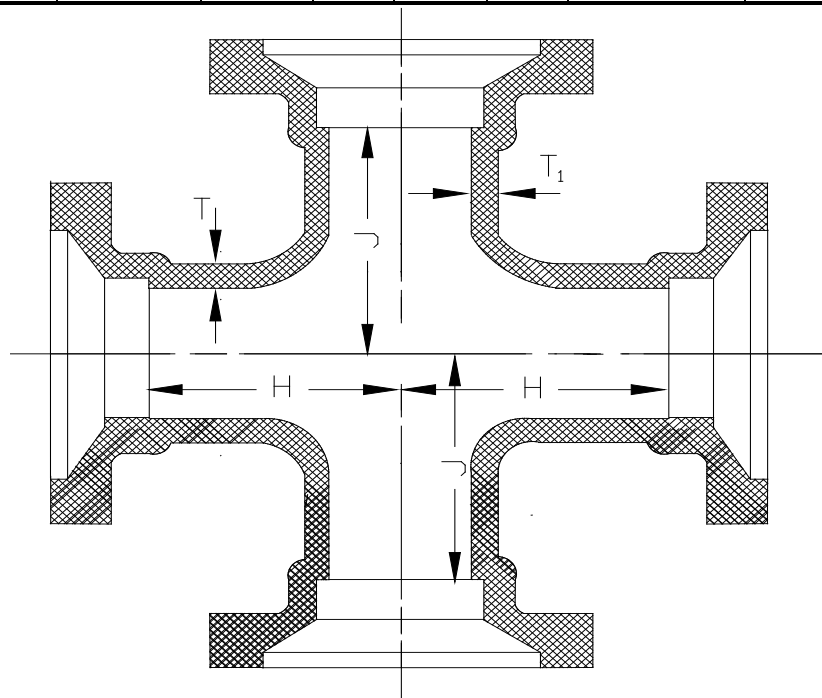

MECHANICAL JOINT CROSSES

(CONTINUED)

RUN in.	BRANCH in.	WEIGHT lbs.	"H" in.	"T" in.	"J" in.	"T1" in.	MATERIAL	RATING psi	SOURCE
36	12	2,630	20.00	1.15	26.00	0.75	DI	250	C110
36	20	2,805	20.00	1.15	26.00	0.80	DI	250	C110
36	24	2,910	20.00	1.15	26.00	0.89	DI	250	C110
36	30	3,965	28.00	1.15	28.00	1.03	DI	250	C110
36	36	4,370	28.00	1.15	28.00	1.15	DI	250	C110
42	12	3,640	23.00	1.28	20.00	0.75	DI	250	C110
42	14	3,675	23.00	1.28	30.00	0.66	DI	250	C110
42	16	3,715	23.00	1.28	30.00	0.70	DI	250	C110
42	18	3,755	23.00	1.28	30.00	0.75	DI	250	C110
42	20	4,645	23.00	1.28	30.00	0.80	DI	250	C110
42	24	3,910	23.00	1.28	30.00	0.89	DI	250	C110
42	30	5,040	31.00	1.28	31.00	1.03	DI	250	C110
42	36	6,655	31.00	1.78	31.00	1.58	DI	250	C110
42	42	7,145	31.00	1.78	31.00	1.78	DI	250	C110
48	12	4,955	26.00	1.42	34.00	0.75	DI	250	C110
48	14	4,985	26.00	1.42	34.00	0.66	DI	250	C110
48	16	5,025	26.00	1.42	34.00	0.70	DI	250	C110
48	18	5,065	26.00	1.42	34.00	0.75	DI	250	C110
48	20	5,115	26.00	1.42	34.00	0.80	DI	250	C110
48	24	5,210	26.00	1.42	34.00	0.89	DI	250	C110
48	30	5,495	26.00	1.42	34.00	1.03	DI	250	C110
48	36	6,790	34.00	1.42	34.00	1.15	DI	250	C110
48	42	8,815	34.00	1.96	34.00	1.78	DI	250	C110
48	48	9,380	34.00	1.96	34.00	1.96	DI	250	C110

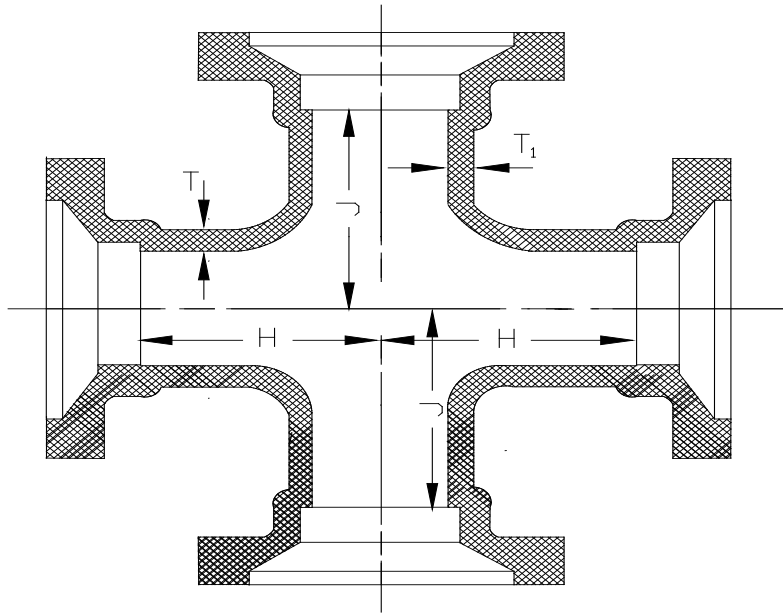

HYDRANT ANCHORING TEES

RUN in.	BRANCH in.	WEIGHT lbs.	"H" in.	"T" in.	"S" in.	"TI" in.	MATERIAL	RATING psi	SOURCE
6	6	64	6.2	0.37	10.00	0.37	DI	350	USP
8	6	79	6.2	0.39	11.00	0.37	DI	350	USP
10	6	104	6.3	0.41	12.50	0.37	DI	350	USP
12	6	129	6.3	0.43	13.50	0.37	DI	350	USP

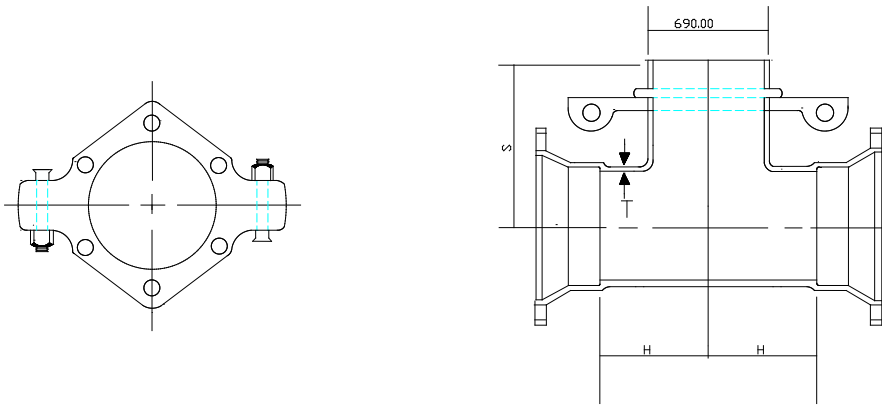

MECHANICAL JOINT TEES

•RUN in.	BRANCH in.	WEIGHT lbs.	"H" in.	"T" in.	"J" in.	"TI" in.	MATERIAL	RATING psi	SOURCE
3	3	28	4.00	0.33	3.00	0.33	DI	350	C153
4	3	30	4.00	0.34	4.00	0.33	DI	350	C153
4	4	32	4.00	0.34	4.00	0.34	DI	350	C153
6	3	42	4.00	0.36	5.00	0.34	DI	350	C153
6	4	46	4.00	0.36	5.00	0.34	DI	350	C153
6	6	56	5.00	0.36	5.00	0.36	DI	350	C153
8	4	60	4.00	0.38	6.50	0.34	DI	350	C153
8	6	72	5.00	0.38	6.50	0.36	DI	350	C153
8	8	86	6.50	0.38	6.50	0.38	DI	350	C153
10	4	78	4.00	0.40	7.50	0.34	DI	350	C153
10	6	90	5.00	0.40	7.50	0.36	DI	350	C153
10	8	105	6.50	0.40	7.50	0.38	DI	350	C153
10	10	120	7.50	0.40	7.50	0.40	DI	350	C153
12	4	94	4.00	0.42	8.75	0.34	DI	350	C153
12	6	110	5.00	0.42	8.75	0.36	DI	350	C153
12	8	125	6.50	0.42	8.75	0.48	DI	350	C153
12	10	140	7.50	0.42	8.75	0.40	DI	350	C153
12	12	160	8.75	0.42	8.75	0.42	DI	350	C153
14	6	183	6.50	0.47	10.50	0.36	DI	350	C153
14	8	206	7.50	0.47	10.50	0.38	DI	350	C153
14	10	229	8.50	0.47	10.50	0.40	DI	350	C153
14	12	235	9.50	0.47	10.50	0.42	DI	350	C153
14	14	281	10.50	0.47	10.50	0.47	DI	350	C153

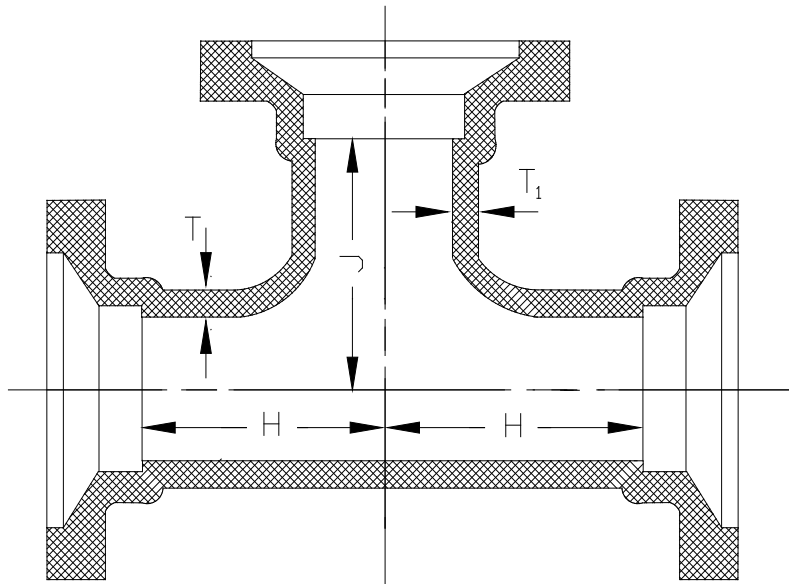

MECHANICAL JOINT TEES
(CONTINUED)

RUN in.	BRANCH in.	WEIGHT lbs.	"H" in.	"T" in.	"J" in.	"T1" in.	MATERIA.L	RATING psi	SOURCE
16	6	229	6.50	0.50	11.50	0.36	DI	350	C153
16	8	248	7.50	0.50	11.50	0.38	DI	350	C153
16	10	265	8.50	0.50	11.50	0.40	DI	350	C153
16	12	281	9.50	0.50	11.50	0.42	DI	350	C153
16	14	317	10.50	0.50	11.50	0.47	DI	350	C153
16	16	323	11.50	0.50	11.50	0.50	DI	350	C153
18	6	275	6.50	0.54	12.50	0.36	DI	350	C153
18	8	280	7.50	0.54	12.50	0.38	DI	350	C153
18	10	286	8.50	0.54	12.50	0.40	DI	350	C153
18	12	370	9.50	0.54	12.50	0.42	DI	350	C153
18	14	415	10.50	0.54	12.50	0.47	DI	350	C153
18	16	445	11.50	0.54	12.50	0.50	DI	350	C153
18	18	490	12.50	0.54	12.50	0.54	DI	350	C153
20	6	335	6.50	0.57	14.00	0.36	DI	350	C153
20	8	383	8.00	0.57	14.00	0.38	DI	350	C153
20	10	410	9.00	0.57	14.00	0.40	DI	350	C153
20	12	432	10.00	0.57	14.00	0.42	DI	350	C153
20	14	475	11.00	0.57	14.00	0.47	DI	350	C153
20	16	530	12.00	0.57	14.00	0.50	DI	350	C153
20	18	560	13.00	0.57	14.00	0.54	DI	350	C153
20	20	605	14.00	0.57	14.00	0.57	DI	350	C153
24	6	465	13.00	0.61	17.00	0.36	DI	350	C153
24	8	475	13.00	0.61	17.00	0.38	DI	350	C153

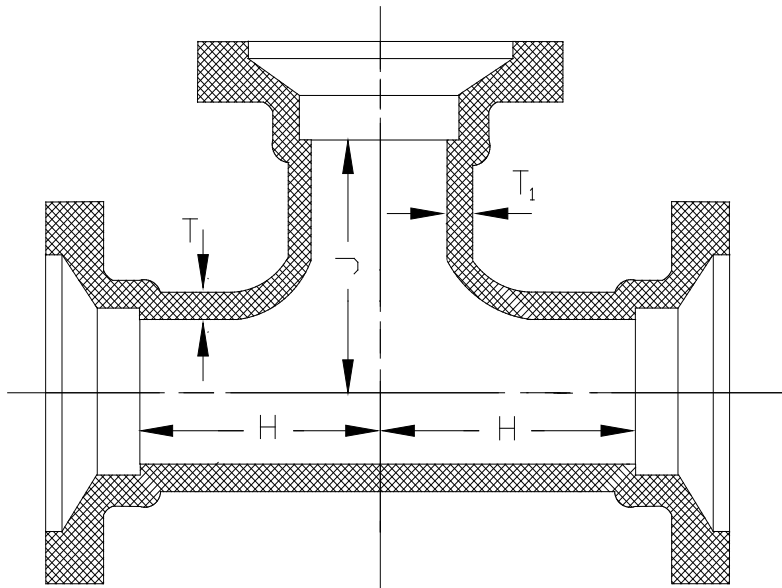

MECHANICAL JOINT TEES
(CONTINUED)

RUN in.	BRANCH in.	WEIGHT lbs.	"H" in.	"T" in.	"J" in.	"TI" in.	MATERIAL	RATING	SOURCE
24	10	516	13.00	0.89	17.00	0.40	DI	350	C153
24	12	549	13.00	0.89	17.00	0.42	DI	350	C153
24	14	585	13.00	0.89	17.00	0.47	DI	350	C153
24	16	625	13.00	0.89	17.00	0.50	DI	350	C153
24	18	675	17.00	0.89	17.00	0.54	DI	350	C153
24	20	740	17.00	0.89	17.00	0.57	DI	350	C153
24	24	844	17.00	0.89	17.00	0.61	DI	350	C153
30	6	1,770	18.00	1.03	23.00	0.55	DI	350	C110
30	8	1,7	18.00	1.03	23.00	0.60	DI	350	C110
30	10	1,760	18.00	1.03	23.00	0.68	DI	350	C110
30	12	1,780	18.00	1.03	23.00	0.75	DI	350	C110
30	14	1,800	18.00	1.03	23.00	0.66	DI	350	C110
30	16	1,820	18.00	1.03	23.00	0.70	DI	350	C110
30	18	1,845	18.00	1.03	23.00	0.75	DI	350	C110
30	20	1,875	18.00	1.03	23.00	0.80	DI	350	C110
30	24	2,400	25.00	1.03	25.00	0.89	DI	350	C110
30	30	2,595	25.00	1.03	25.00	1.03	DI	350	C110
36	8	2,520	20.00	1.15	20.00	0.60	DI	350	C110
36	10	2,535	20.00	1.15	20.00	0.68	DI	350	C110
36	12	2,550	20.00	1.15	20.00	0.75	DI	350	C110
36	14	2,570	20.00	1.15	20.00	0.66	DI	350	C110
36	16	2,585	20.00	1.15	20.00	0.70	DI	350	C110
36	18	2,610	20.00	1.15	20.00	0.75	DI	350	C110

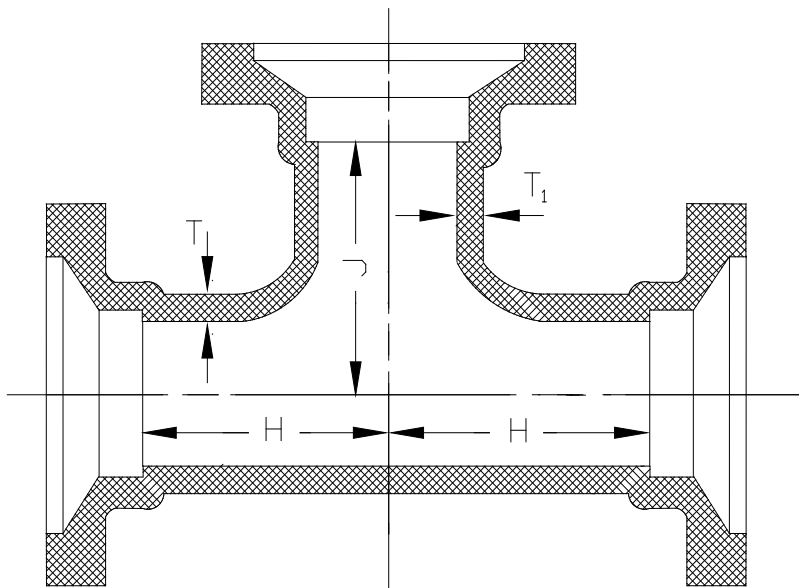

MECHANICAL JOINT TEES
(CONTINUED)

RUN in.	BRANCH in.	WEIGHT lbs.	"H" in.	"T" in.	"J" in.	"TI" in.	MATERIAL	RATING psi	SOURCE
36	20	2,635	20.00	1.15	26.00	0.80	DI	250	C110
36	24	2,792	20.00	1.15	26.00	0.89	DI	250	C110
36	30	3,545	28.00	1.15	28.00	1.03	DI	250	C110
36	36	3,745	28.00	1.15	28.00	1.15	DI	250	C110
42	12	3,555	23.00	1.28	20.00	0.75	DI	250	C110
42	14	3,575	23.00	1.28	30.00	0.66	DI	250	C110
42	16	3,595	23.00	1.28	30.00	0.70	DI	250	C110
42	18	3,615	23.00	1.28	30.00	0.75	DI	250	C110
42	20	3,640	23.00	1.28	30.00	0.80	DI	250	C110
42	24	3,690	23.00	1.28	30.00	0.89	DI	250	C110
42	30	4,650	31.00	1.28	31.00	1.03	DI	250	C110
42	36	4,880	31.00	1.78	31.00	1.58	DI	250	C110
42	42	6,320	31.00	1.78	31.00	1.78	DI	250	C110
48	12	4,870	26.00	1.42	34.00	0.75	DI	250	C110
48	14	4,855	26.00	1.42	34.00	0.66	DI	250	C110
48	16	4,905	26.00	1.42	34.00	0.70	DI	250	C110
48	18	4,925	26.00	1.42	34.00	0.75	DI	250	C110
48	20	4,950	26.00	1.42	34.00	0.80	DI	250	C110
48	24	4,995	26.00	1.42	34.0	0.89	DI	250	C110
48	30	5,140	26.00	1.42	34.00	1.03	DI	250	C110
48	36	6,280	34.00	1.42	34.00	1.15	DI	250	C110
48	42	8,130	34.00	1.96	34.00	1.78	DI	250	C110
48	48	8,420	34.00	1.96	34.00	1.96	DI	250	C110

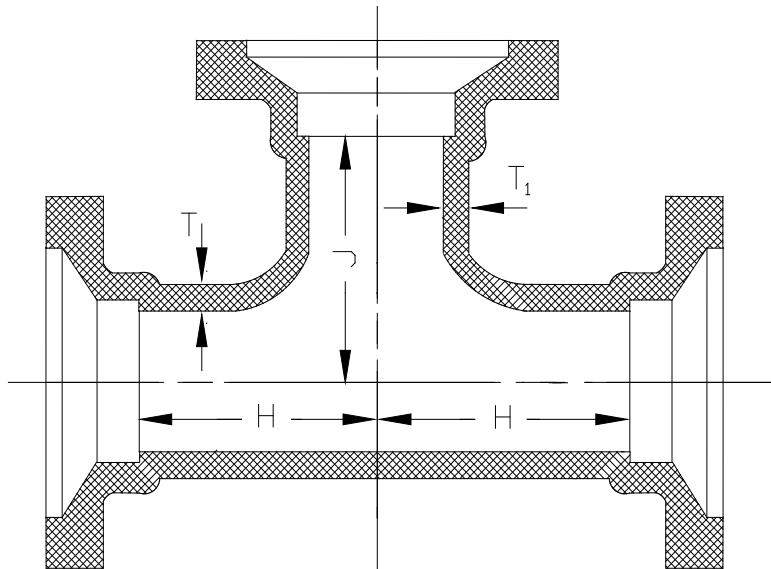

MECHANICAL JOINTS 1/4 BENDS
(90 DEGREES)

<u>SIZE</u> in.	<u>WEIGHT</u> lbs.	<u>"A"</u> in.	<u>"T"</u> in.	<u>MATERIAL</u>	<u>RATING</u> psi.	<u>SOURCE</u>
3	20	3.50	0.33	DI	350	C153
4	26	4.00	0.34	DI	350	C153
6	43	5.00	0.36	DI	350	C153
8	64	6.50	0.38	DI	350	C153
10	96	7.50	0.40	DI	350	C153
12	122	9.00	0.42	DI	350	C153
14	220	11.50	0.47	DI	350	C153
16	264	12.50	0.50	DI	350	C153
18	410	14.50	0.54	DI	350	C153
20	525	15.00	0.57	DI	350	C153
24	664	17.00	0.61	DI	350	C153
30	1,690	25.00	1.03	DI	250	C110
36	2,475	28.00	1.15	DI	250	C110
42	3,410	31.00	1.28	DI	250	C110
48	4,595	34.00	1.42	DI	250	C110

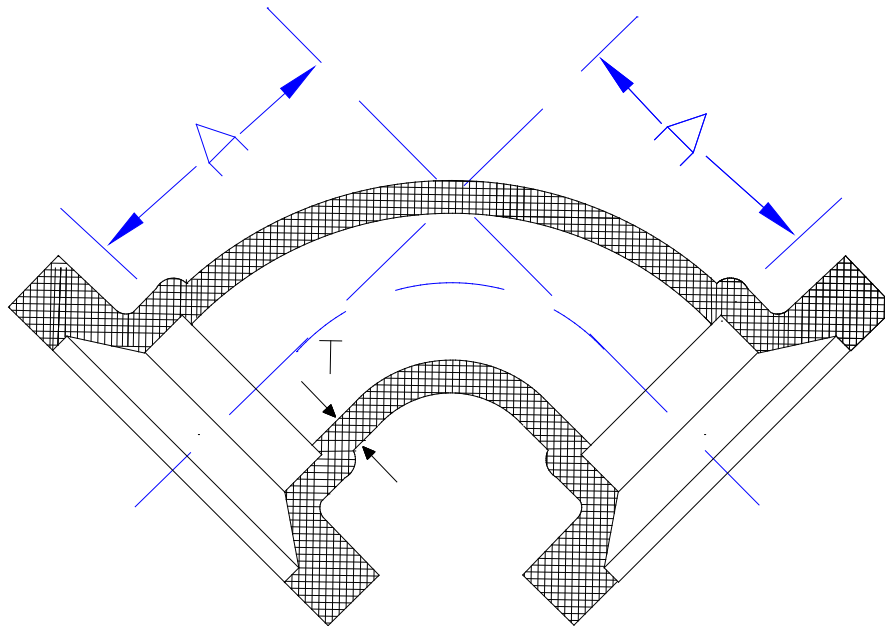

90 ° Bends

MECHANICAL JOINT 1/8 BENDS
(45 DEGREES)

<u>SIZE</u> in.	<u>WEIGHT</u> lbs.	<u>"A"</u> in.	<u>"T"</u> in.	<u>MATERIAL</u>	<u>RATING</u> psi	<u>SOURCE</u>
3	21	1.50	0.33	DI	350	C153
4	36	2.00	0.34	DI	350	C153
6	32	3.00	0.36	DI	350	C153
8	50	3.50	0.38	DI	350	C153
10	74	4.50	0.40	DI	350	C153
12	101	5.50	0.42	DI	350	C153
14	164	5.50	0.47	DI	350	C153
16	202	5.50	0.50	DI	350	C153
18	289	6.00	0.54	DI	350	C153
20	348	7.00	0.57	DI	350	C153
24	475	7.50	0.61	DI	350	C153
30	1,380	15.00	1.03	DI	250	C110
36	2,095	18.00	1.15	DI	250	C110
42	2,955	21.00	1.28	DI	250	C110
48	4,080	24.00	1.42	DI	250	C110

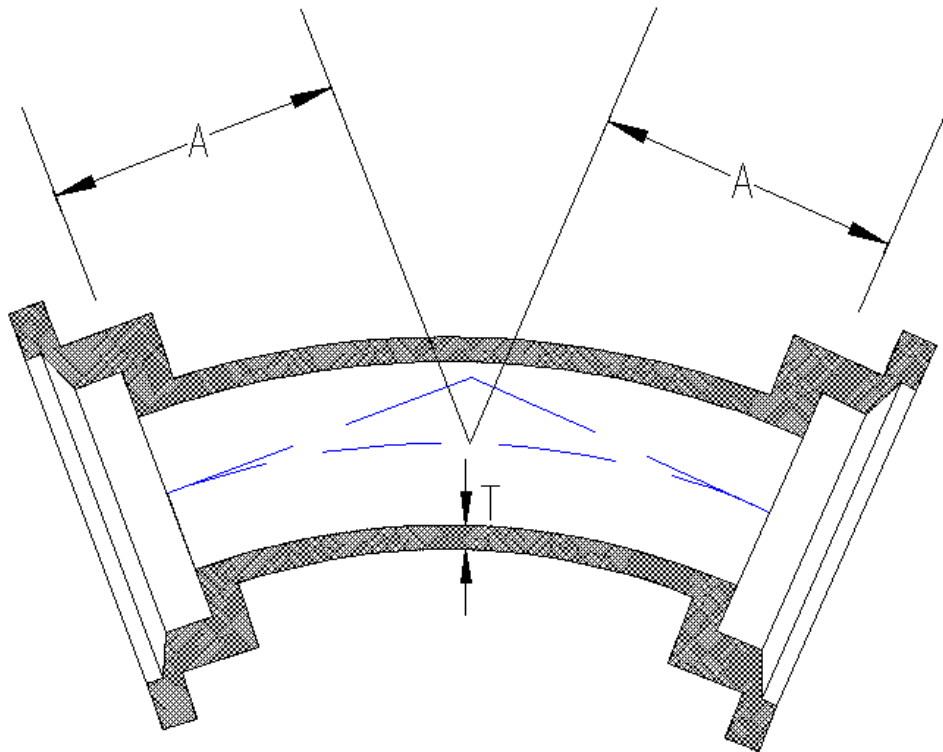

45° BENDS

MECHANICAL JOINT 1/16 BENDS
(22 1/2 DEGREES)

<u>SIZE</u> in.	<u>WEIGHT</u> lbs.	<u>"A"</u> in.	<u>"T"</u> in.	<u>MATERIAL</u>	<u>RATING</u> psi	<u>SOURCE</u>
3	16	1.00	0.33	DI	350	C153
4	21	1.50	0.34	DI	350	C153
6	34	2.00	0.36	DI	350	C153
8	46	2.50	0.38	DI	350	C153
10	67	3.00	0.40	DI	350	C153
12	84	3.50	0.42	DI	350	C153
14	148	3.75	0.47	DI	350	C153
16	178	4.00	0.50	DI	350	C153
18	292	4.50	0.54	DI	350	C153
20	364	4.50	0.57	DI	350	C153
24	384	4.50	0.61	DI	350	C153
30	1,400	15.00	1.03	DI	250	C110
36	2,135	18.00	1.15	DI	250	C110
42	3,020	21.00	1.28	DI	250	C110
48	4,170	24.00	1.42	DI	250	C110

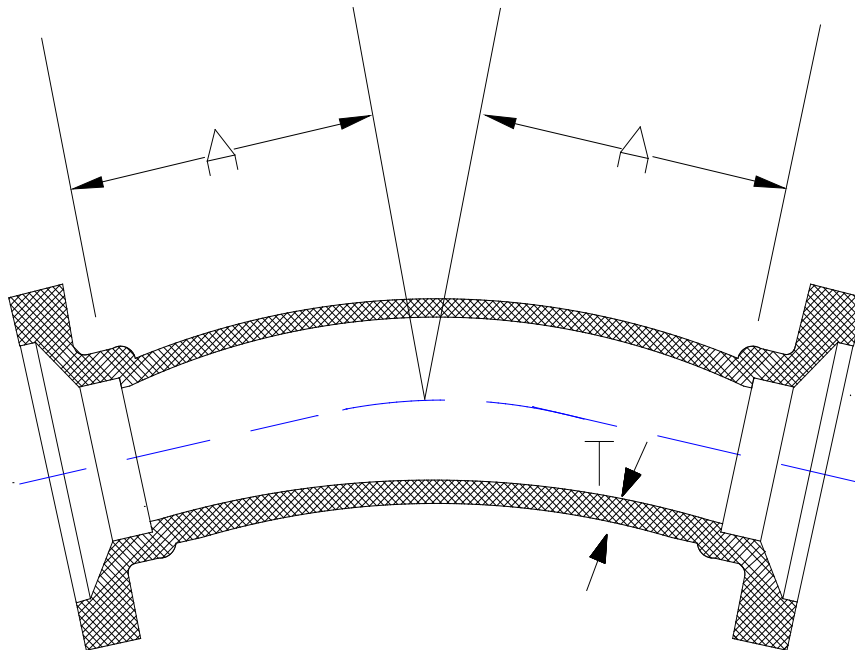

22 1/2° BENDS

MECHANICAL JOINT 1/32 BENDS

(11 1/4 DEGREES)

<u>SIZE</u> in.	<u>WEIGHT</u> lbs.	<u>"A"</u> in.	<u>"T"</u> in.	<u>MATERIAL</u>	<u>RATING</u> psi	<u>SOURCE</u>
3	14	1.00	0.33	DI	350	C153
4	16	1.25	0.34	DI	350	C153
6	30	1.50	0.36	DI	350	C153
8	42	1.75	0.38	DI	350	C153
10	58	2.00	0.40	DI	350	C153
12	74	2.25	0.42	DI	350	C153
14	93	2.50	0.47	DI	350	C153
16	148	2.50	0.50	DI	350	C153
18	205	3.00	0.54	DI	350	C153
20	245	3.00	0.57	DI	350	C153
24	315	3.00	0.61	DI	350	C153
30	1,410	15.00	1.03	DI	250	C110
36	2,145	18.00	1.15	DI	250	C110
42	3,035	21.00	1.28	DI	250	C110
48	4,190	24.00	1.42	DI	250	C110

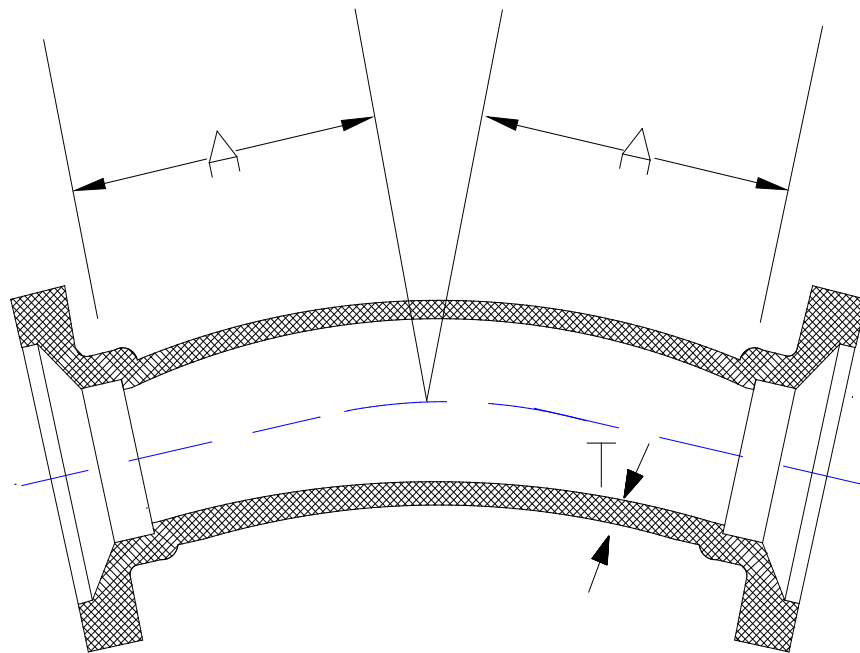

11 1/4° BENDS

MECHANICAL JOINT OFFSETS

SIZE in.	"D" in.	WEIGHT lbs.	"L" in.	"T" in.	MATERIAL	RATING psi	SOURCE
3	6	50	19	0.48	DI	250	C110
3	12	60	22	0.48	DI	250	C110
3	18	75	30	0.48	DI	250	C110
4	6	75	19	0.52	DI	250	C110
4	12	85	22	0.52	DI	250	C110
4	18	105	30	0.52	DI	250	C110
6	6	110	20	0.55	DI	250	C110
6	12	148	26	0.55	DI	250	C110
6	18	165	33	0.55	DI	250	C110
8	6	177	21	0.60	DI	250	C110
8	12	231	28	0.60	DI	250	C110
8	18	287	35	0.60	DI	250	C110
10	6	220	22	0.68	DI	250	C110
10	12	280	30	0.68	DI	250	C110
10	18	340	38	0.68	DI	250	C110
12	6	320	26	0.75	DI	250	C110
12	12	420	37	0.75	DI	250	C110
12	18	520	48	0.75	DI	250	C110
14	6	365	27	0.66	DI	350	C110
14	12	465	38	0.66	DI	350	C110
14	18	570	49	0.66	DI	350	C110
16	6	440	27	0.70	DI	350	C110
16	12	715	40	0.70	DI	350	C110
16	18	850	50	0.70	DI	350	C110

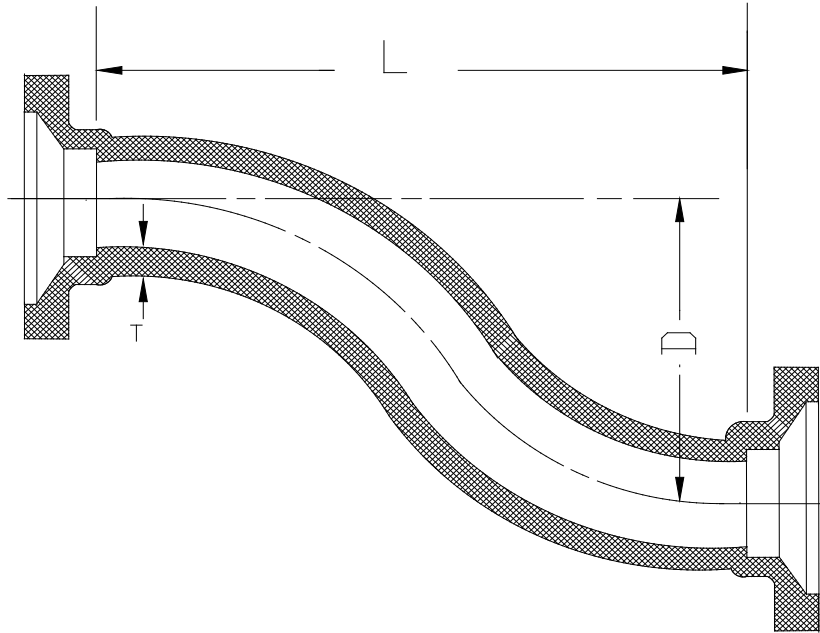

MECHANICAL JOINT REDUCERS

FROM in.	TO in.	WEIGHT lbs.	"L" in.	"T" in.	"TI" in.	MATERIAL	RATING psi	SOURCE
4	3	18	3	0.34	0.33	DI	350	C153
6	3	28	5	0.36	0.33	DI	350	C153
6	4	28	4	0.36	0.34	DI	350	C153
8	4	36	5	0.38	0.34	DI	350	C153
8	6	39	4	0.38	0.36	DI	350	C153
10	4	53	7	0.40	0.34	DI	350	C153
10	6	59	5	0.40	0.36	DI	350	C153
10	8	54	4	0.40	0.38	DI	350	C153
12	4	67	9	0.42	0.34	DI	350	C153
12	6	64	7	0.42	0.36	DI	350	C153
12	8	60	5	0.42	0.38	DI	350	C153
12	10	63	4	0.42	0.40	DI	350	C153
14	6	104	9	0.47	0.36	DI	350	C153
14	8	104	7	0.47	0.38	DI	350	C153
14	10	100	5	0.47	0.40	DI	350	C153
14	12	100	4	0.47	0.42	DI	350	C153
16	6	132	11	0.50	0.36	DI	350	C153
16	8	136	9	0.50	0.38	DI	350	C153
16	10	128	7	0.50	0.40	DI	350	C153
16	12	120	5	0.50	0.42	DI	350	C153
16	14	140	4	0.50	0.47	DI	350	C153
18	8	201	12	0.54	0.38	DI	350	C153
18	10	196	10	0.54	0.40	DI	350	C153

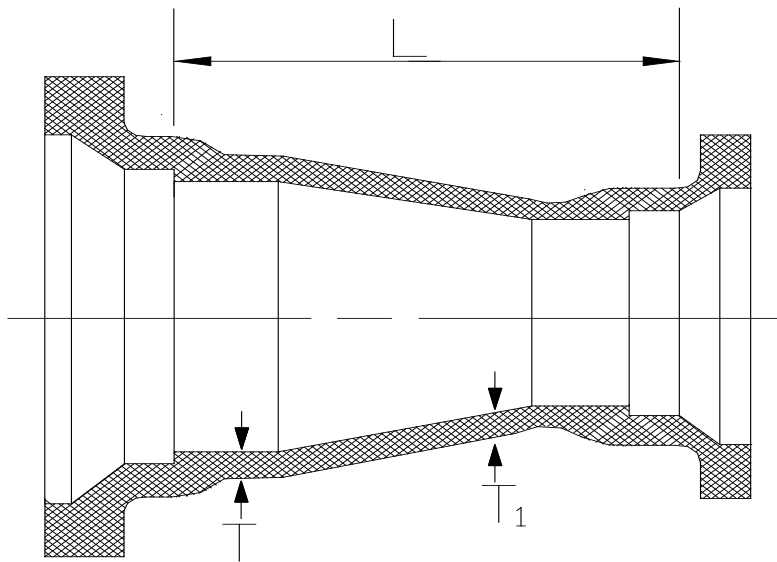

MECHANICAL JOINT REDUCERS

(CONTINUED)

FROM in.	TO in.	WEIGHT Lbs.	"L" in.	"T" in.	"T1" in.	MATERIAL	RATING psi	SOURCE
18	12	175	10	0.75	0.42	DI	350	C153
18	14	180	8	0.75	0.47	DI	350	C153
18	16	194	7	0.75	0.50	DI	350	C153
20	10	225	14	0.80	0.40	DI	350	C153
20	12	214	12	0.80	0.42	DI	350	C153
20	14	208	10	0.80	0.47	DI	350	C153
20	16	225	8	0.80	0.50	DI	350	C153
20	18	233	8	0.80	0.54	DI	350	C153
24	12	320	16	0.89	0.42	DI	350	C153
24	14	314	14	0.89	0.47	DI	350	C153
24	16	325	12	0.89	0.50	DI	350	C153
24	18	325	10	0.89	0.54	DI	350	C153
24	20	315	7	0.89	0.57	DI	350	C153
30	18	970	30	1.03	1.03	DI	250	C110
30	20	1,225	30	1.03	1.03	DI	250	C110
30	24	1,360	30	1.03	1.03	DI	250	C110
36	20	1,495	36	1.15	1.15	DI	250	C110
36	24	1,580	36	1.15	1.15	DI	250	C110
36	30	1,919	36	1.15	1.15	DI	250	C110
42	20	1,980	42	1.28	1.28	DI	250	C110
42	24	2,060	42	1.28	1.28	DI	250	C110
42	30	2,370	42	1.28	1.28	DI	250	C110
42	36	2,695	42	1.28	1.28	DI	250	C110

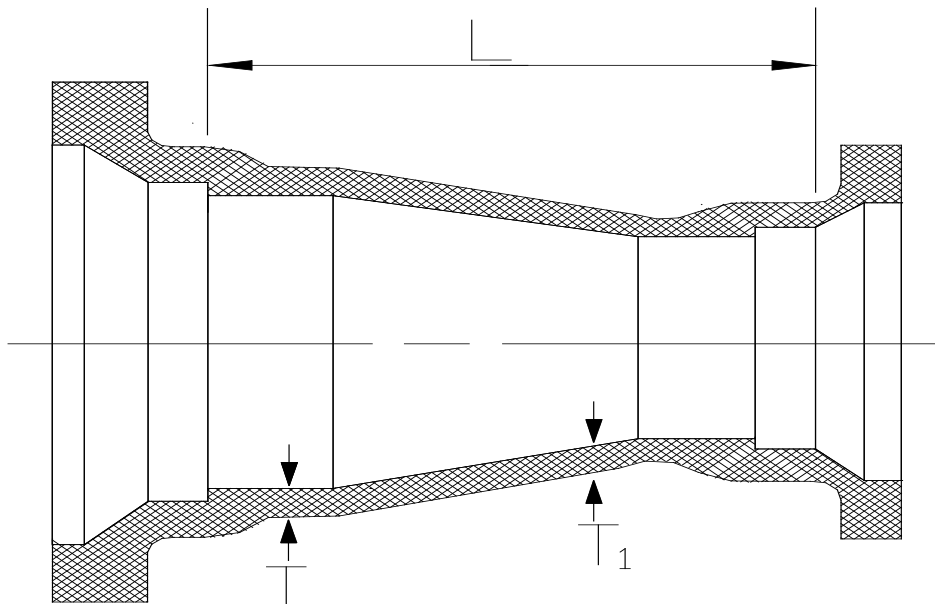

MECHANICAL JOINT REDUCERS

(CONTINUED)

FROM in.	TO in.	WEIGHT lbs.	"L" in.	"T" in.	"TI" in.	MATERIAL	RATING psi	SOURCE
48	30	3,005	48	1.42	1.03	DI	250	C110
48	36	3,370	48	1.42	1.15	DI	250	C110
48	42	3,750	48	1.42	1.28	DI	250	C110

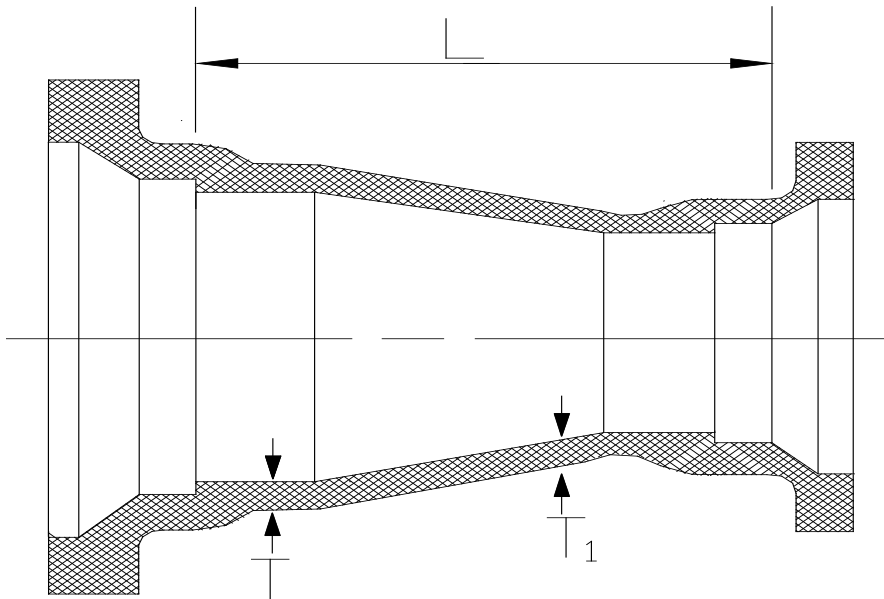

MECHANICAL JOINT LONG SLEEVES

SIZE in.	WEIGHT lbs.	"L" in.	"T" in.	MATERIAL	RATING psi	SOURCE
3	19	12.0	0.34	DI	350	C153
4	25	12.0	0.35	DI	350	C153
6	36	12.0	0.37	DI	350	C153
8	52	12.0	0.39	DI	350	C153
10	64	12.0	0.41	DI	350	C153
12	82	12.0	0.43	DI	350	C153
14	141	15.0	0.56	DI	350	C153
16	170	15.0	0.57	DI	350	C153
18	200	15.0	0.68	DI	350	C153
20	269	15.0	0.69	DI	350	C153
24	368	15.0	0.75	DI	350	C153
30	1,085	24.0	1.37	DI	250	C110
36	1,495	24.0	1.58	DI	250	C110
42	1,940	24.0	1.78	DI	250	C110
48	2,405	24.0	1.96	DI	250	C110

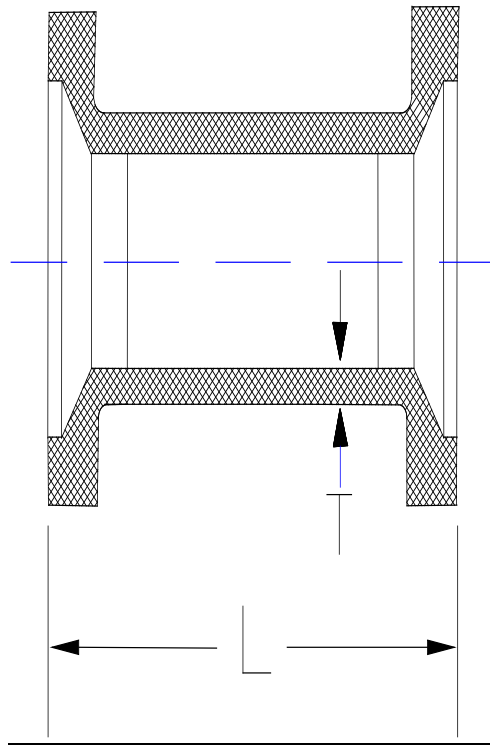

MECHANICAL JOINT SHORT SLEEVES

SIZE in.	WEIGHT lbs.	"L" in.	"T" in.	MATERIAL	RATING psi	SOURCE
3	16	7.5	0.33	DI	350	C153
4	18	7.5	0.34	DI	350	C153
6	28	7.5	0.36	DI	350	C153
8	38	7.5	0.38	DI	350	C153
10	52	7.5	0.40	DI	350	C153
12	66	7.5	0.42	DI	350	C153
14	111	9.5	0.47	DI	350	C153
16	130	9.5	0.50	DI	350	C153
18	160	9.5	0.54	DI	350	C153
20	212	9.5	0.57	DI	350	C153
24	272	9.5	0.61	DI	350	C153
30	745	15.0	1.37	DI	350	C110
36	1,030	15.0	1.58	DI	350	C110
42	1,330	15.0	1.78	DI	350	C110
48	1,645	15.0	1.96	DI	350	C110

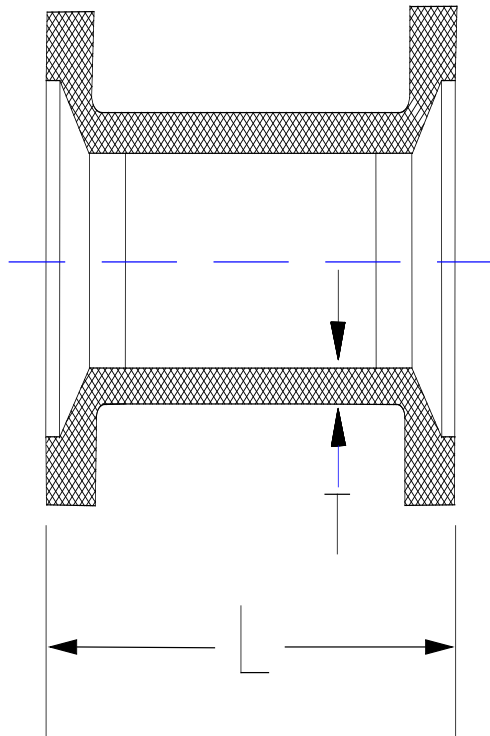

MECHANICAL JOINT CAPS AND PLUGS

SIZE in.	CAP lbs.	PLUG lbs.	"T" in.	MATERIA	RATING psi	SOURCE
3	12	10	0.50	25	350	C110
4	15	15	0.60	25	350	C110
6	25	25	0.65	25	350	C110
8	45	45	0.70	25	350	C110
10	60	65	0.75	25	350	C110
12	80	85	0.75	25	350	C110
14	120	115	0.82	DI	250	C110
16	155	145	0.89	DI	250	C110
18	195	185	0.96	DI	250	C110
20	240	225	1.03	DI	250	C110
24	345	335	1.16	DI	250	C110
30	590	575	1.03	DI	250	C110
36	850	815	1.15	DI	250	C110
42	1,180	1,100	1.28	DI	250	C110
48	1,595	1,455	1.42	DI	250	C110

